



13

Gear Trains

Features

1. Introduction.
2. Types of Gear Trains.
3. Simple Gear Train.
4. Compound Gear Train.
5. Design of Spur Gears.
6. Reverted Gear Train.
7. Epicyclic Gear Train.
8. Velocity Ratio of Epicyclic Gear Train.
9. Compound Epicyclic Gear Train (Sun and Planet Wheel).
10. Epicyclic Gear Train With Bevel Gears.
11. Torques in Epicyclic Gear Trains.

13.1. Introduction

Sometimes, two or more gears are made to mesh with each other to transmit power from one shaft to another. Such a combination is called *gear train* or *train of toothed wheels*. The nature of the train used depends upon the velocity ratio required and the relative position of the axes of shafts. A gear train may consist of spur, bevel or spiral gears.

13.2. Types of Gear Trains

Following are the different types of gear trains, depending upon the arrangement of wheels :

1. Simple gear train, **2.** Compound gear train, **3.** Reverted gear train, and **4.** Epicyclic gear train.

In the first three types of gear trains, the axes of the shafts over which the gears are mounted are fixed relative to each other. But in case of epicyclic gear trains, the axes of the shafts on which the gears are mounted may move relative to a fixed axis.

13.3. Simple Gear Train

When there is only one gear on each shaft, as shown in Fig. 13.1, it is known as *simple gear train*. The gears are represented by their pitch circles.

When the distance between the two shafts is small, the two gears 1 and 2 are made to mesh with each other to





transmit motion from one shaft to the other, as shown in Fig. 13.1 (a). Since the gear 1 drives the gear 2, therefore gear 1 is called the **driver** and the gear 2 is called the **driven** or **follower**. It may be noted that the motion of the driven gear is opposite to the motion of driving gear.

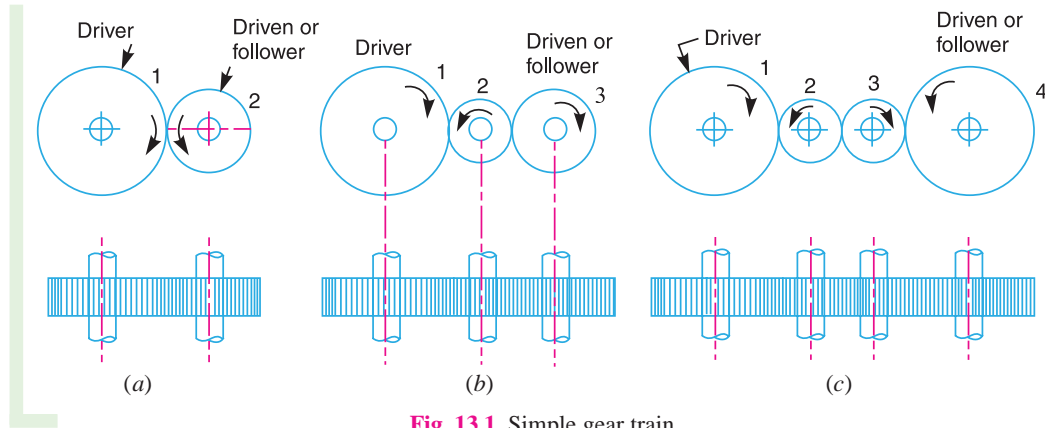

Fig. 13.1. Simple gear train.

Let

$$N_1 = \text{Speed of gear 1 (or driver) in r.p.m.,}$$

$$N_2 = \text{Speed of gear 2 (or driven or follower) in r.p.m.,}$$

$$T_1 = \text{Number of teeth on gear 1, and}$$

$$T_2 = \text{Number of teeth on gear 2.}$$

Since the speed ratio (or velocity ratio) of gear train is the ratio of the speed of the driver to the speed of the driven or follower and ratio of speeds of any pair of gears in mesh is the inverse of their number of teeth, therefore

$$\text{Speed ratio} = \frac{N_1}{N_2} = \frac{T_2}{T_1}$$

It may be noted that ratio of the speed of the driven or follower to the speed of the driver is known as **train value** of the gear train. Mathematically,

$$\text{Train value} = \frac{N_2}{N_1} = \frac{T_1}{T_2}$$

From above, we see that the train value is the reciprocal of speed ratio.

Sometimes, the distance between the two gears is large. The motion from one gear to another, in such a case, may be transmitted by either of the following two methods :

1. By providing the large sized gear, or
2. By providing one or more intermediate gears.

A little consideration will show that the former method (*i.e.* providing large sized gears) is very inconvenient and uneconomical method ; whereas the latter method (*i.e.* providing one or more intermediate gear) is very convenient and economical.

It may be noted that when the number of intermediate gears are **odd**, the motion of both the gears (*i.e.* driver and driven or follower) is **like** as shown in Fig. 13.1 (b).

But if the number of intermediate gears are **even**, the motion of the driven or follower will be in the opposite direction of the driver as shown in Fig. 13.1 (c).

Now consider a simple train of gears with one intermediate gear as shown in Fig. 13.1 (b).

Let

$$N_1 = \text{Speed of driver in r.p.m.,}$$

$$N_2 = \text{Speed of intermediate gear in r.p.m.,}$$



430 • Theory of Machines

N_3 = Speed of driven or follower in r.p.m.,
 T_1 = Number of teeth on driver,
 T_2 = Number of teeth on intermediate gear, and
 T_3 = Number of teeth on driven or follower.

Since the driving gear 1 is in mesh with the intermediate gear 2, therefore speed ratio for these two gears is

$$\frac{N_1}{N_2} = \frac{T_2}{T_1} \quad \dots(i)$$

Similarly, as the intermediate gear 2 is in mesh with the driven gear 3, therefore speed ratio for these two gears is

$$\frac{N_2}{N_3} = \frac{T_3}{T_2} \quad \dots(ii)$$

The speed ratio of the gear train as shown in Fig. 13.1 (b) is obtained by multiplying the equations (i) and (ii).

$$\therefore \frac{N_1}{N_2} \times \frac{N_2}{N_3} = \frac{T_2}{T_1} \times \frac{T_3}{T_2} \quad \text{or} \quad \frac{N_1}{N_3} = \frac{T_3}{T_1}$$

i.e. Speed ratio = $\frac{\text{Speed of driver}}{\text{Speed of driven}} = \frac{\text{No. of teeth on driven}}{\text{No. of teeth on driver}}$

and Train value = $\frac{\text{Speed of driven}}{\text{Speed of driver}} = \frac{\text{No. of teeth on driver}}{\text{No. of teeth on driven}}$

Similarly, it can be proved that the above equation holds good even if there are any number of intermediate gears. From above, we see that the speed ratio and the train value, in a simple train of gears, is independent of the size and number of intermediate gears. These intermediate gears are called **idle gears**, as they do not effect the speed ratio or train value of the system. The idle gears are used for the following two purposes :

1. To connect gears where a large centre distance is required, and
2. To obtain the desired direction of motion of the driven gear (*i.e.* clockwise or anticlockwise).



Gear trains inside a mechanical watch

13.4. Compound Gear Train

When there are more than one gear on a shaft, as shown in Fig. 13.2, it is called a **compound train of gear**.

We have seen in Art. 13.3 that the idle gears, in a simple train of gears do not effect the speed ratio of the system. But these gears are useful in bridging over the space between the driver and the driven.





But whenever the distance between the driver and the driven or follower has to be bridged over by intermediate gears and at the same time a great (or much less) speed ratio is required, then the advantage of intermediate gears is intensified by providing compound gears on intermediate shafts. In this case, each intermediate shaft has two gears rigidly fixed to it so that they may have the same speed. One of these two gears meshes with the driver and the other with the driven or follower attached to the next shaft as shown in Fig.13.2.

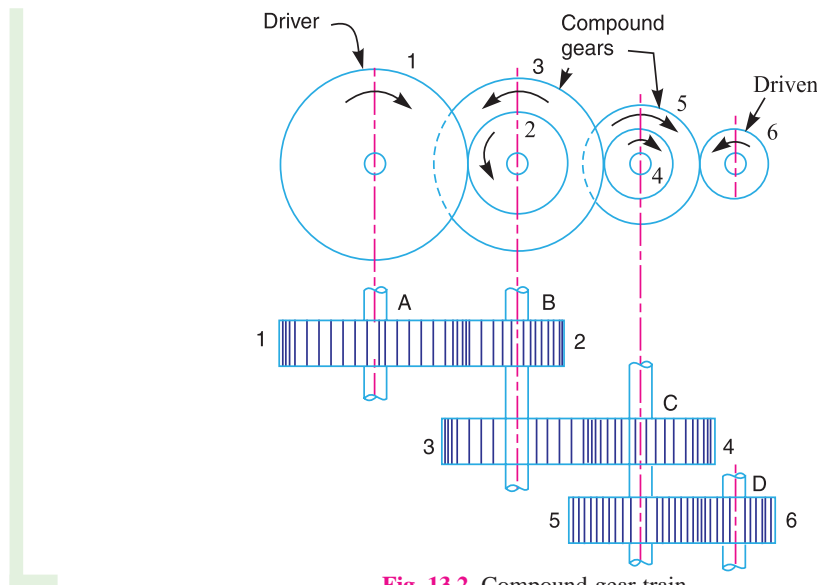

Fig. 13.2. Compound gear train.

In a compound train of gears, as shown in Fig. 13.2, the gear 1 is the driving gear mounted on shaft A, gears 2 and 3 are compound gears which are mounted on shaft B. The gears 4 and 5 are also compound gears which are mounted on shaft C and the gear 6 is the driven gear mounted on shaft D.

Let N_1 = Speed of driving gear 1,
 T_1 = Number of teeth on driving gear 1,
 N_2, N_3, \dots, N_6 = Speed of respective gears in r.p.m., and
 T_2, T_3, \dots, T_6 = Number of teeth on respective gears.

Since gear 1 is in mesh with gear 2, therefore its speed ratio is

$$\frac{N_1}{N_2} = \frac{T_2}{T_1} \quad \dots(i)$$

Similarly, for gears 3 and 4, speed ratio is

$$\frac{N_3}{N_4} = \frac{T_4}{T_3} \quad \dots(ii)$$

and for gears 5 and 6, speed ratio is

$$\frac{N_5}{N_6} = \frac{T_6}{T_5} \quad \dots(iii)$$

The speed ratio of compound gear train is obtained by multiplying the equations (i), (ii) and (iii),

$$\therefore \frac{N_1}{N_2} \times \frac{N_3}{N_4} \times \frac{N_5}{N_6} = \frac{T_2}{T_1} \times \frac{T_4}{T_3} \times \frac{T_6}{T_5} \quad \text{or} \quad \frac{N_1}{N_6} = \frac{T_2 \times T_4 \times T_6}{T_1 \times T_3 \times T_5}$$

* Since gears 2 and 3 are mounted on one shaft B, therefore $N_2 = N_3$. Similarly gears 4 and 5 are mounted on shaft C, therefore $N_4 = N_5$.





432 • Theory of Machines

i.e. Speed ratio = $\frac{\text{Speed of the first driver}}{\text{Speed of the last driven or follower}}$
 $= \frac{\text{Product of the number of teeth on the drivers}}{\text{Product of the number of teeth on the driven}}$

and Train value = $\frac{\text{Speed of the last driven or follower}}{\text{Speed of the first driver}}$
 $= \frac{\text{Product of the number of teeth on the drivers}}{\text{Product of the number of teeth on the driven}}$

The advantage of a compound train over a simple gear train is that a much larger speed reduction from the first shaft to the last shaft can be obtained with small gears. If a simple gear train is used to give a large speed reduction, the last gear has to be very large. Usually for a speed reduction in excess of 7 to 1, a simple train is not used and a compound train or worm gearing is employed.

Note: The gears which mesh must have the same circular pitch or module. Thus gears 1 and 2 must have the same module as they mesh together. Similarly gears 3 and 4, and gears 5 and 6 must have the same module.

Example 13.1. The gearing of a machine tool is shown in Fig. 13.3. The motor shaft is connected to gear A and rotates at 975 r.p.m. The gear wheels B, C, D and E are fixed to parallel shafts rotating together. The final gear F is fixed on the output shaft. What is the speed of gear F? The number of teeth on each gear are as given below :

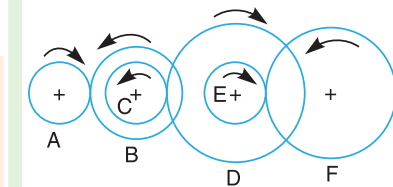

Fig. 13.3

Gear	A	B	C	D	E	F
No. of teeth	20	50	25	75	26	65

Solution. Given : $N_A = 975$ r.p.m. ;
 $T_A = 20$; $T_B = 50$; $T_C = 25$; $T_D = 75$; $T_E = 26$;
 $T_F = 65$

From Fig. 13.3, we see that gears A, C and E are drivers while the gears B, D and F are driven or followers. Let the gear A rotates in clockwise direction. Since the gears B and C are mounted on the same shaft, therefore it is a compound gear and the direction or rotation of both these gears is same (*i.e.* anticlockwise). Similarly, the gears D and E are mounted on the same shaft, therefore it is also a compound gear and the direction of rotation of both these gears is same (*i.e.* clockwise). The gear F will rotate in anticlockwise direction.

Let $N_F =$ Speed of gear F, *i.e.* last driven or follower.

We know that

$$\frac{\text{Speed of the first driver}}{\text{Speed of the last driven}} = \frac{\text{Product of no. of teeth on drivers}}{\text{Product of no. of teeth on driven}}$$



Battery Car: Even though it is run by batteries, the power transmission, gears, clutches, brakes, etc. remain mechanical in nature.

Note : This picture is given as additional information and is not a direct example of the current chapter.





or
$$\frac{N_A}{N_F} = \frac{T_B \times T_D \times T_F}{T_A \times T_C \times T_E} = \frac{50 \times 75 \times 65}{20 \times 25 \times 26} = 18.75$$

$\therefore N_F = \frac{N_A}{18.75} = \frac{975}{18.75} = 52 \text{ r. p. m. Ans.}$

13.5. Design of Spur Gears

Sometimes, the spur gears (*i.e.* driver and driven) are to be designed for the given velocity ratio and distance between the centres of their shafts.

Let x = Distance between the centres of two shafts,
 N_1 = Speed of the driver,
 T_1 = Number of teeth on the driver,
 d_1 = Pitch circle diameter of the driver,
 N_2, T_2 and d_2 = Corresponding values for the driven or follower, and
 p_c = Circular pitch.

We know that the distance between the centres of two shafts,

$$x = \frac{d_1 + d_2}{2} \quad \dots(i)$$

and speed ratio or velocity ratio,

$$\frac{N_1}{N_2} = \frac{d_2}{d_1} = \frac{T_2}{T_1} \quad \dots(ii)$$

From the above equations, we can conveniently find out the values of d_1 and d_2 (or T_1 and T_2) and the circular pitch (p_c). The values of T_1 and T_2 , as obtained above, may or may not be whole numbers. But in a gear since the number of its teeth is always a whole number, therefore a slight alterations must be made in the values of x , d_1 and d_2 , so that the number of teeth in the two gears may be a complete number.

Example 13.2. Two parallel shafts, about 600 mm apart are to be connected by spur gears. One shaft is to run at 360 r.p.m. and the other at 120 r.p.m. Design the gears, if the circular pitch is to be 25 mm.

Solution. Given : $x = 600 \text{ mm}$; $N_1 = 360 \text{ r.p.m.}$; $N_2 = 120 \text{ r.p.m.}$; $p_c = 25 \text{ mm}$

Let d_1 = Pitch circle diameter of the first gear, and
 d_2 = Pitch circle diameter of the second gear.

We know that speed ratio,

$$\frac{N_1}{N_2} = \frac{d_2}{d_1} = \frac{360}{120} = 3 \quad \text{or} \quad d_2 = 3d_1 \quad \dots(i)$$

and centre distance between the shafts (x),

$$600 = \frac{1}{2} (d_1 + d_2) \quad \text{or} \quad d_1 + d_2 = 1200 \quad \dots(ii)$$

From equations (i) and (ii), we find that

$$d_1 = 300 \text{ mm, and } d_2 = 900 \text{ mm}$$

\therefore Number of teeth on the first gear,

$$T_1 = \frac{\pi d_1}{p_c} = \frac{\pi \times 300}{25} = 37.7$$





434 • Theory of Machines

and number of teeth on the second gear,

$$T_2 = \frac{\pi d_2}{p_c} = \frac{\pi \times 900}{25} = 113.1$$

Since the number of teeth on both the gears are to be in complete numbers, therefore let us make the number of teeth on the first gear as 38. Therefore for a speed ratio of 3, the number of teeth on the second gear should be $38 \times 3 = 114$.

Now the exact pitch circle diameter of the first gear,

$$d_1' = \frac{T_1 \times p_c}{\pi} = \frac{38 \times 25}{\pi} = 302.36 \text{ mm}$$

and the exact pitch circle diameter of the second gear,

$$d_2' = \frac{T_2 \times p_c}{\pi} = \frac{114 \times 25}{\pi} = 907.1 \text{ mm}$$

∴ Exact distance between the two shafts,

$$x' = \frac{d_1' + d_2'}{2} = \frac{302.36 + 907.1}{2} = 604.73 \text{ mm}$$

Hence the number of teeth on the first and second gear must be 38 and 114 and their pitch circle diameters must be 302.36 mm and 907.1 mm respectively. The exact distance between the two shafts must be 604.73 mm. **Ans.**

13.6. Reverted Gear Train

When the axes of the first gear (*i.e.* first driver) and the last gear (*i.e.* last driven or follower) are co-axial, then the gear train is known as **reverted gear train** as shown in Fig. 13.4.

We see that gear 1 (*i.e.* first driver) drives the gear 2 (*i.e.* first driven or follower) in the opposite direction. Since the gears 2 and 3 are mounted on the same shaft, therefore they form a compound gear and the gear 3 will rotate in the same direction as that of gear 2. The gear 3 (which is now the second driver) drives the gear 4 (*i.e.* the last driven or follower) in the same direction as that of gear 1. Thus we see that in a reverted gear train, the motion of the first gear and the last gear is **like**.

Let T_1 = Number of teeth on gear 1,
 r_1 = Pitch circle radius of gear 1, and
 N_1 = Speed of gear 1 in r.p.m.

Similarly,

T_2, T_3, T_4 = Number of teeth on respective gears,
 r_2, r_3, r_4 = Pitch circle radii of respective gears, and
 N_2, N_3, N_4 = Speed of respective gears in r.p.m.

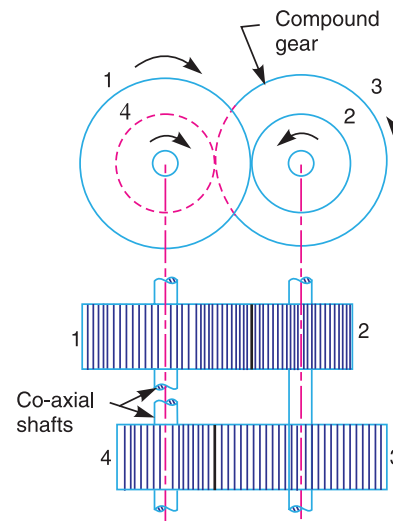

Fig. 13.4. Reverted gear train.





Since the distance between the centres of the shafts of gears 1 and 2 as well as gears 3 and 4 is same, therefore

$$r_1 + r_2 = r_3 + r_4 \quad \dots(i)$$

Also, the circular pitch or module of all the gears is assumed to be same, therefore number of teeth on each gear is directly proportional to its circumference or radius.

$$\therefore \quad *T_1 + T_2 = T_3 + T_4 \quad \dots(ii)$$

and

$$\text{Speed ratio} = \frac{\text{Product of number of teeth on drivers}}{\text{Product of number of teeth on driven}}$$

or

$$\frac{N_1}{N_4} = \frac{T_2 \times T_4}{T_1 \times T_3} \quad \dots (iii)$$

From equations (i), (ii) and (iii), we can determine the number of teeth on each gear for the given centre distance, speed ratio and module only when the number of teeth on one gear is chosen arbitrarily.

The reverted gear trains are used in automotive transmissions, lathe back gears, industrial speed reducers, and in clocks (where the minute and hour hand shafts are co-axial).

Example 13.3. The speed ratio of the reverted gear train, as shown in Fig. 13.5, is to be 12. The module pitch of gears A and B is 3.125 mm and of gears C and D is 2.5 mm. Calculate the suitable numbers of teeth for the gears. No gear is to have less than 24 teeth.

Solution. Given : Speed ratio, $N_A/N_D = 12$;
 $m_A = m_B = 3.125$ mm ; $m_C = m_D = 2.5$ mm

- Let N_A = Speed of gear A,
- T_A = Number of teeth on gear A,
- r_A = Pitch circle radius of gear A,
- N_B, N_C, N_D = Speed of respective gears,
- T_B, T_C, T_D = Number of teeth on respective gears, and
- r_B, r_C, r_D = Pitch circle radii of respective gears.

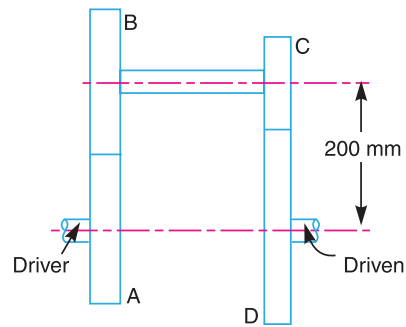

Fig. 13.5

* We know that circular pitch,

$$p_c = \frac{2\pi r}{T} = \pi m \quad \text{or} \quad r = \frac{mT}{2}, \text{ where } m \text{ is the module.}$$

$$\therefore \quad r_1 = \frac{mT_1}{2} ; r_2 = \frac{mT_2}{2} ; r_3 = \frac{mT_3}{2} ; r_4 = \frac{mT_4}{2}$$

Now from equation (i),

$$\frac{mT_1}{2} + \frac{mT_2}{2} = \frac{mT_3}{2} + \frac{mT_4}{2}$$

$$T_1 + T_2 = T_3 + T_4$$





436 • Theory of Machines

Since the speed ratio between the gears A and B and between the gears C and D are to be same, therefore

$$* \frac{N_A}{N_B} = \frac{N_C}{N_D} = \sqrt{12} = 3.464$$

Also the speed ratio of any pair of gears in mesh is the inverse of their number of teeth, therefore

$$\frac{T_B}{T_A} = \frac{T_D}{T_C} = 3.464 \quad \dots(i)$$

We know that the distance between the shafts

$$x = r_A + r_B = r_C + r_D = 200 \text{ mm}$$

or
$$\frac{m_A \cdot T_A}{2} + \frac{m_B \cdot T_B}{2} = \frac{m_C \cdot T_C}{2} + \frac{m_D \cdot T_D}{2} = 200 \quad \dots \left(\because r = \frac{m \cdot T}{2} \right)$$

$$3.125 (T_A + T_B) = 2.5 (T_C + T_D) = 400 \quad \dots(\because m_A = m_B, \text{ and } m_C = m_D)$$

$\therefore T_A + T_B = 400 / 3.125 = 128 \quad \dots(ii)$

and $T_C + T_D = 400 / 2.5 = 160 \quad \dots(iii)$

From equation (i), $T_B = 3.464 T_A$. Substituting this value of T_B in equation (ii),

$$T_A + 3.464 T_A = 128 \quad \text{or} \quad T_A = 128 / 4.464 = 28.67 \text{ say } 28 \text{ Ans.}$$

and $T_B = 128 - 28 = 100 \text{ Ans.}$

Again from equation (i), $T_D = 3.464 T_C$. Substituting this value of T_D in equation (iii),

$$T_C + 3.464 T_C = 160 \quad \text{or} \quad T_C = 160 / 4.464 = 35.84 \text{ say } 36 \text{ Ans.}$$

and $T_D = 160 - 36 = 124 \text{ Ans.}$

Note : The speed ratio of the reverted gear train with the calculated values of number of teeth on each gear is

$$\frac{N_A}{N_D} = \frac{T_B \times T_D}{T_A \times T_C} = \frac{100 \times 124}{28 \times 36} = 12.3$$

13.7. Epicyclic Gear Train

We have already discussed that in an epicyclic gear train, the axes of the shafts, over which the gears are mounted, may move relative to a fixed axis. A simple epicyclic gear train is shown in Fig. 13.6, where a gear A and the arm C have a common axis at O_1 about which they can rotate. The gear B meshes with gear A and has its axis on the arm at O_2 , about which the gear B can rotate. If the

* We know that speed ratio
$$= \frac{\text{Speed of first driver}}{\text{Speed of last driven}} = \frac{N_A}{N_D} = 12$$

Also
$$\frac{N_A}{N_D} = \frac{N_A}{N_B} \times \frac{N_C}{N_D} \quad \dots(N_B = N_C, \text{ being on the same shaft})$$

For $\frac{N_A}{N_B}$ and $\frac{N_C}{N_D}$ to be same, each speed ratio should be $\sqrt{12}$ so that

$$\frac{N_A}{N_D} = \frac{N_A}{N_B} \times \frac{N_C}{N_D} = \sqrt{12} \times \sqrt{12} = 12$$





arm is fixed, the gear train is simple and gear A can drive gear B or *vice-versa*, but if gear A is fixed and the arm is rotated about the axis of gear A (i.e. O_1), then the gear B is forced to rotate *upon* and *around* gear A . Such a motion is called **epicyclic** and the gear trains arranged in such a manner that one or more of their members move upon and around another member are known as **epicyclic gear trains** (*epi.* means upon and *cyclic* means around). The epicyclic gear trains may be *simple* or *compound*.

The epicyclic gear trains are useful for transmitting high velocity ratios with gears of moderate size in a comparatively lesser space. The epicyclic gear trains are used in the back gear of lathe, differential gears of the automobiles, hoists, pulley blocks, wrist watches etc.

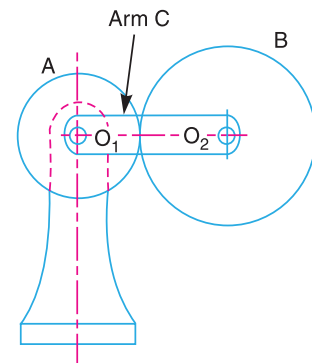

Fig. 13.6. Epicyclic gear train.

13.8. Velocity Ratio of Epicyclic Gear Train

The following two methods may be used for finding out the velocity ratio of an epicyclic gear train.

1. Tabular method, and
2. Algebraic method.

These methods are discussed, in detail, as follows :

1. **Tabular method.** Consider an epicyclic gear train as shown in Fig. 13.6.

Let T_A = Number of teeth on gear A , and
 T_B = Number of teeth on gear B .

First of all, let us suppose that the arm is fixed. Therefore the axes of both the gears are also fixed relative to each other. When the gear A makes one revolution anticlockwise, the gear B will make $*T_A / T_B$ revolutions, clockwise. Assuming the anticlockwise rotation as positive and clockwise as negative, we may say that when gear A makes + 1 revolution, then the gear B will make $(-T_A / T_B)$ revolutions. This statement of relative motion is entered in the first row of the table (see Table 13.1).

Secondly, if the gear A makes + x revolutions, then the gear B will make $-x \times T_A / T_B$ revolutions. This statement is entered in the second row of the table. In other words, multiply the each motion (entered in the first row) by x .

Thirdly, each element of an epicyclic train is given + y revolutions and entered in the third row. Finally, the motion of each element of the gear train is added up and entered in the fourth row.



Inside view of a car engine.

Note : This picture is given as additional information and is not a direct example of the current chapter.

* We know that $N_B / N_A = T_A / T_B$. Since $N_A = 1$ revolution, therefore $N_B = T_A / T_B$.





Table 13.1. Table of motions

Step No.	Conditions of motion	Revolutions of elements		
		Arm C	Gear A	Gear B
1.	Arm fixed-gear A rotates through + 1 revolution <i>i.e.</i> 1 rev. anticlockwise	0	+ 1	$-\frac{T_A}{T_B}$
2.	Arm fixed-gear A rotates through + x revolutions	0	+ x	$-x \times \frac{T_A}{T_B}$
3.	Add + y revolutions to all elements	+ y	+ y	+ y
4.	Total motion	+ y	+ $x + y$	$y - x \times \frac{T_A}{T_B}$

A little consideration will show that when two conditions about the motion of rotation of any two elements are known, then the unknown speed of the third element may be obtained by substituting the given data in the third column of the fourth row.

2. Algebraic method. In this method, the motion of each element of the epicyclic train relative to the arm is set down in the form of equations. The number of equations depends upon the number of elements in the gear train. But the two conditions are, usually, supplied in any epicyclic train *viz.* some element is fixed and the other has specified motion. These two conditions are sufficient to solve all the equations ; and hence to determine the motion of any element in the epicyclic gear train.

Let the arm C be fixed in an epicyclic gear train as shown in Fig. 13.6. Therefore speed of the gear A relative to the arm C

$$= N_A - N_C$$

and speed of the gear B relative to the arm C,

$$= N_B - N_C$$

Since the gears A and B are meshing directly, therefore they will revolve in **opposite** directions.

$$\therefore \frac{N_B - N_C}{N_A - N_C} = -\frac{T_A}{T_B}$$

Since the arm C is fixed, therefore its speed, $N_C = 0$.

$$\therefore \frac{N_B}{N_A} = -\frac{T_A}{T_B}$$

If the gear A is fixed, then $N_A = 0$.

$$\frac{N_B - N_C}{0 - N_C} = -\frac{T_A}{T_B} \quad \text{or} \quad \frac{N_B}{N_C} = 1 + \frac{T_A}{T_B}$$

Note : The tabular method is easier and hence mostly used in solving problems on epicyclic gear train.

Example 13.4. In an epicyclic gear train, an arm carries two gears A and B having 36 and 45 teeth respectively. If the arm rotates at 150 r.p.m. in the anticlockwise direction about the centre of the gear A which is fixed, determine the speed of gear B. If the gear A instead of being fixed, makes 300 r.p.m. in the clockwise direction, what will be the speed of gear B ?

Solution. Given : $T_A = 36$; $T_B = 45$; $N_C = 150$ r.p.m. (anticlockwise)

The gear train is shown in Fig. 13.7.

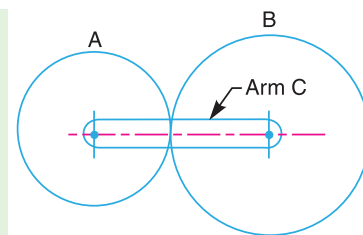

Fig. 13.7





We shall solve this example, first by tabular method and then by algebraic method.

1. Tabular method

First of all prepare the table of motions as given below :

Table 13.2. Table of motions.

Step No.	Conditions of motion	Revolutions of elements		
		Arm C	Gear A	Gear B
1.	Arm fixed-gear A rotates through + 1 revolution (<i>i.e.</i> 1 rev. anticlockwise)	0	+ 1	$-\frac{T_A}{T_B}$
2.	Arm fixed-gear A rotates through + x revolutions	0	+ x	$-x \times \frac{T_A}{T_B}$
3.	Add + y revolutions to all elements	+ y	+ y	+ y
4.	Total motion	+ y	+ $x + y$	$y - x \times \frac{T_A}{T_B}$

Speed of gear B when gear A is fixed

Since the speed of arm is 150 r.p.m. anticlockwise, therefore from the fourth row of the table,

$$y = + 150 \text{ r.p.m.}$$

Also the gear A is fixed, therefore

$$x + y = 0 \quad \text{or} \quad x = -y = -150 \text{ r.p.m.}$$

$$\begin{aligned} \therefore \text{Speed of gear B, } N_B &= y - x \times \frac{T_A}{T_B} = 150 + 150 \times \frac{36}{45} = + 270 \text{ r.p.m.} \\ &= 270 \text{ r.p.m. (anticlockwise) } \quad \text{Ans.} \end{aligned}$$

Speed of gear B when gear A makes 300 r.p.m. clockwise

Since the gear A makes 300 r.p.m. clockwise, therefore from the fourth row of the table,

$$x + y = -300 \quad \text{or} \quad x = -300 - y = -300 - 150 = -450 \text{ r.p.m.}$$

\therefore Speed of gear B,

$$\begin{aligned} N_B &= y - x \times \frac{T_A}{T_B} = 150 + 450 \times \frac{36}{45} = + 510 \text{ r.p.m.} \\ &= 510 \text{ r.p.m. (anticlockwise) } \quad \text{Ans.} \end{aligned}$$

2. Algebraic method

Let N_A = Speed of gear A.
 N_B = Speed of gear B, and
 N_C = Speed of arm C.

Assuming the arm C to be fixed, speed of gear A relative to arm C

$$= N_A - N_C$$

and speed of gear B relative to arm C = $N_B - N_C$





440 • Theory of Machines

Since the gears A and B revolve in *opposite* directions, therefore

$$\frac{N_B - N_C}{N_A - N_C} = -\frac{T_A}{T_B} \quad \dots(i)$$

Speed of gear B when gear A is fixed

When gear A is fixed, the arm rotates at 150 r.p.m. in the anticlockwise direction, *i.e.*

$$N_A = 0, \quad \text{and} \quad N_C = +150 \text{ r.p.m.}$$

$$\therefore \frac{N_B - 150}{0 - 150} = -\frac{36}{45} = -0.8 \quad \dots[\text{From equation (i)}]$$

or $N_B = -150 \times -0.8 + 150 = 120 + 150 = 270 \text{ r.p.m.}$ **Ans.**

Speed of gear B when gear A makes 300 r.p.m. clockwise

Since the gear A makes 300 r.p.m. clockwise, therefore

$$N_A = -300 \text{ r.p.m.}$$

$$\therefore \frac{N_B - 150}{-300 - 150} = -\frac{36}{45} = -0.8$$

or $N_B = -450 \times -0.8 + 150 = 360 + 150 = 510 \text{ r.p.m.}$ **Ans.**

Example 13.5. In a reverted epicyclic gear train, the arm A carries two gears B and C and a compound gear $D - E$. The gear B meshes with gear E and the gear C meshes with gear D . The number of teeth on gears B , C and D are 75, 30 and 90 respectively. Find the speed and direction of gear C when gear B is fixed and the arm A makes 100 r.p.m. clockwise.

Solution. Given : $T_B = 75$; $T_C = 30$; $T_D = 90$;
 $N_A = 100 \text{ r.p.m. (clockwise)}$

The reverted epicyclic gear train is shown in Fig. 13.8. First of all, let us find the number of teeth on gear E (T_E). Let d_B , d_C , d_D and d_E be the pitch circle diameters of gears B , C , D and E respectively. From the geometry of the figure,

$$d_B + d_E = d_C + d_D$$

Since the number of teeth on each gear, for the same module, are proportional to their pitch circle diameters, therefore

$$T_B + T_E = T_C + T_D$$

$$\therefore T_E = T_C + T_D - T_B = 30 + 90 - 75 = 45$$

The table of motions is drawn as follows :

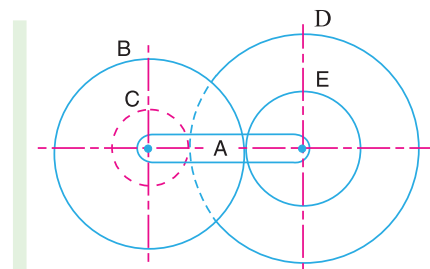

Fig. 13.8



A gear-cutting machine is used to cut gears.

Note : This picture is given as additional information and is not a direct example of the current chapter.





Table 13.3. Table of motions.

Step No.	Conditions of motion	Revolutions of elements			
		Arm A	Compound gear D-E	Gear B	Gear C
1.	Arm fixed-compound gear D-E rotated through + 1 revolution (i.e. 1 rev. anticlockwise)	0	+ 1	$-\frac{T_E}{T_B}$	$-\frac{T_D}{T_C}$
2.	Arm fixed-compound gear D-E rotated through + x revolutions	0	+x	$-x \times \frac{T_E}{T_B}$	$-x \times \frac{T_D}{T_C}$
3.	Add + y revolutions to all elements	+y	+y	+y	+y
4.	Total motion	+y	x+y	$y - x \times \frac{T_E}{T_B}$	$y - x \times \frac{T_D}{T_C}$

Since the gear B is fixed, therefore from the fourth row of the table,

$$y - x \times \frac{T_E}{T_B} = 0 \quad \text{or} \quad y - x \times \frac{45}{75} = 0$$

$$\therefore y - 0.6 = 0 \quad \dots(i)$$

Also the arm A makes 100 r.p.m. clockwise, therefore

$$y = -100 \quad \dots(ii)$$

Substituting $y = -100$ in equation (i), we get

$$-100 - 0.6x = 0 \quad \text{or} \quad x = -100 / 0.6 = -166.67$$

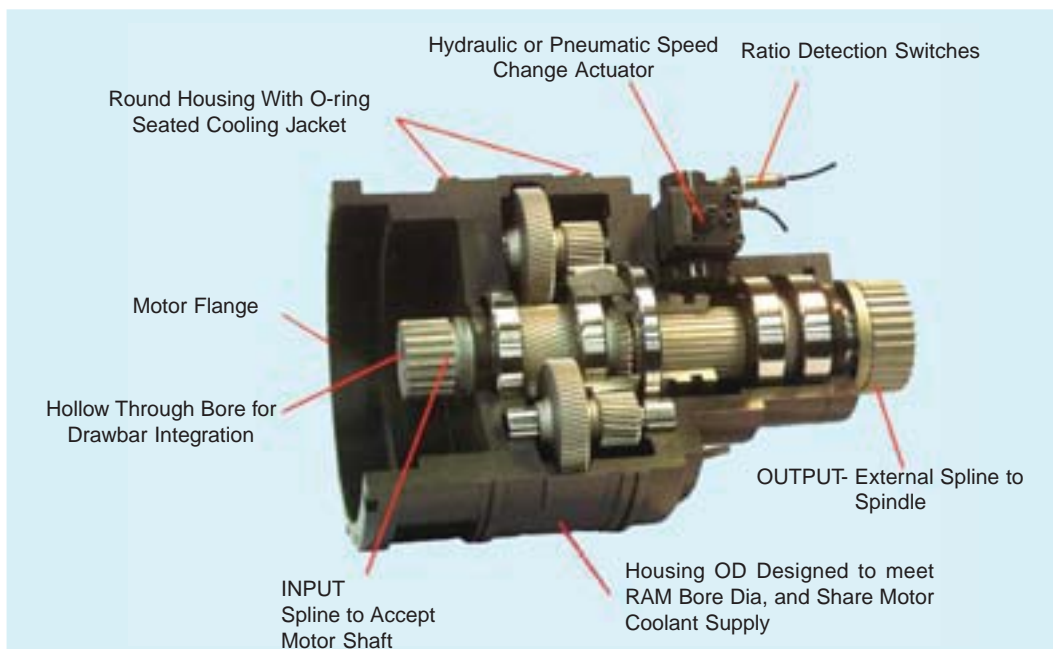

Model of sun and planet gears.





442 • Theory of Machines

From the fourth row of the table, speed of gear C ,

$$N_C = y - x \times \frac{T_D}{T_C} = -100 + 166.67 \times \frac{90}{30} = +400 \text{ r.p.m.}$$

$$= 400 \text{ r.p.m. (anticlockwise) Ans.}$$

13.9. Compound Epicyclic Gear Train—Sun and Planet Gear

A compound epicyclic gear train is shown in Fig. 13.9. It consists of two co-axial shafts S_1 and S_2 , an annulus gear A which is fixed, the compound gear (or planet gear) $B-C$, the sun gear D and the arm H . The annulus gear has internal teeth and the compound gear is carried by the arm and revolves freely on a pin of the arm H . The sun gear is co-axial with the annulus gear and the arm but independent of them.

The annulus gear A meshes with the gear B and the sun gear D meshes with the gear C . It may be noted that when the annulus gear is fixed, the sun gear provides the drive and when the sun gear is fixed, the annulus gear provides the drive. In both cases, the arm acts as a follower.

Note : The gear at the centre is called the *sun gear* and the gears whose axes move are called *planet gears*.

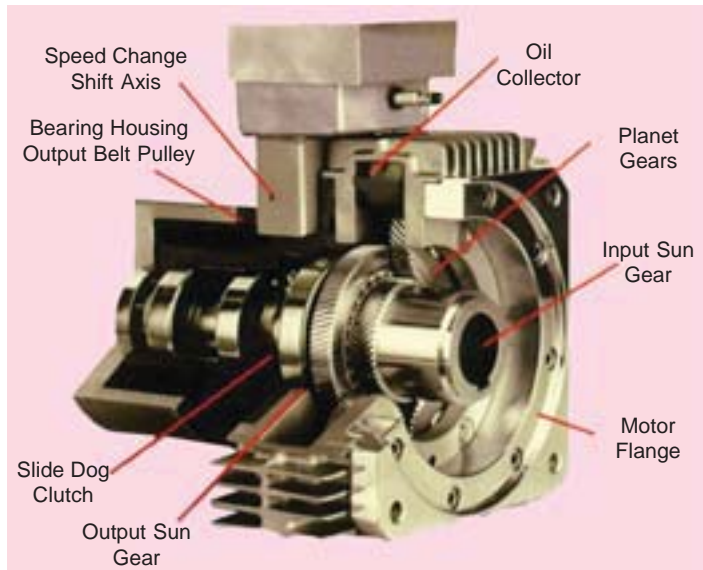

Sun and Planet gears.

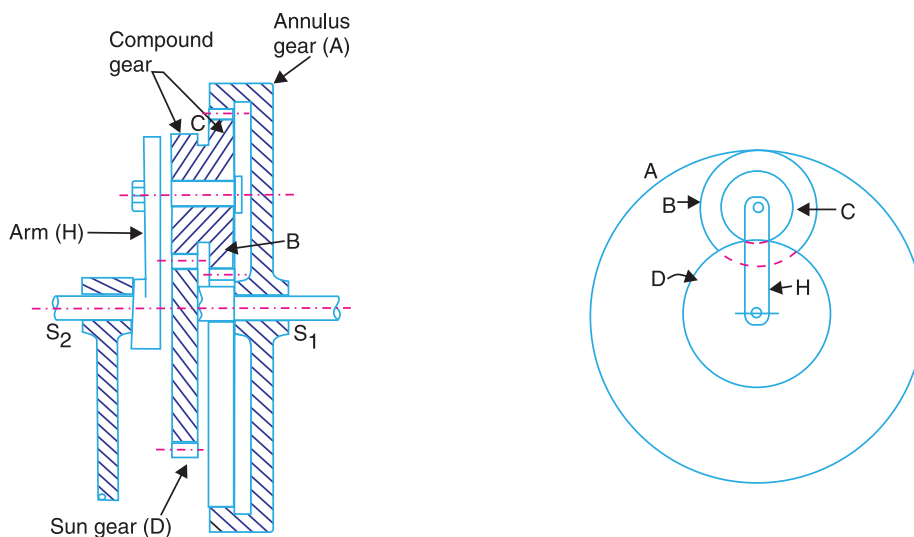

Fig. 13.9. Compound epicyclic gear train.





Let T_A, T_B, T_C , and T_D be the teeth and N_A, N_B, N_C and N_D be the speeds for the gears A, B, C and D respectively. A little consideration will show that when the arm is fixed and the sun gear D is turned anticlockwise, then the compound gear $B-C$ and the annulus gear A will rotate in the clockwise direction.

The motion of rotations of the various elements are shown in the table below.

Table 13.4. Table of motions.

Step No.	Conditions of motion	Revolutions of elements			
		Arm	Gear D	Compound gear B-C	Gear A
1.	Arm fixed-gear D rotates through + 1 revolution	0	+ 1	$-\frac{T_D}{T_C}$	$-\frac{T_D}{T_C} \times \frac{T_B}{T_A}$
2.	Arm fixed-gear D rotates through + x revolutions	0	+ x	$-x \times \frac{T_D}{T_C}$	$-x \times \frac{T_D}{T_C} \times \frac{T_B}{T_A}$
3.	Add + y revolutions to all elements	+ y	+ y	+ y	+ y
4.	Total motion	+ y	+ $x + y$	$y - x \times \frac{T_D}{T_C}$	$y - x \times \frac{T_D}{T_C} \times \frac{T_B}{T_A}$

Note : If the annulus gear A is rotated through one revolution anticlockwise with the arm fixed, then the compound gear rotates through T_A / T_B revolutions in the same sense and the sun gear D rotates through $T_A / T_B \times T_C / T_D$ revolutions in clockwise direction.

Example 13.6. An epicyclic gear consists of three gears A, B and C as shown in Fig. 13.10. The gear A has 72 internal teeth and gear C has 32 external teeth. The gear B meshes with both A and C and is carried on an arm EF which rotates about the centre of A at 18 r.p.m.. If the gear A is fixed, determine the speed of gears B and C .

Solution. Given : $T_A = 72$; $T_C = 32$; Speed of arm $EF = 18$ r.p.m.

Considering the relative motion of rotation as shown in Table 13.5.

Table 13.5. Table of motions.

Step No.	Conditions of motion	Revolutions of elements			
		Arm EF	Gear C	Gear B	Gear A
1.	Arm fixed-gear C rotates through + 1 revolution (i.e. 1 rev. anticlockwise)	0	+ 1	$-\frac{T_C}{T_B}$	$-\frac{T_C}{T_B} \times \frac{T_B}{T_A} = -\frac{T_C}{T_A}$
2.	Arm fixed-gear C rotates through + x revolutions	0	+ x	$-x \times \frac{T_C}{T_B}$	$-x \times \frac{T_C}{T_A}$
3.	Add + y revolutions to all elements	+ y	+ y	+ y	+ y
4.	Total motion	+ y	+ $x + y$	$y - x \times \frac{T_C}{T_B}$	$y - x \times \frac{T_C}{T_A}$





444 • Theory of Machines

Speed of gear C

We know that the speed of the arm is 18 r.p.m. therefore,

$$y = 18 \text{ r.p.m.}$$

and the gear A is fixed, therefore

$$y - x \times \frac{T_C}{T_A} = 0 \quad \text{or} \quad 18 - x \times \frac{32}{72} = 0$$

$$\therefore x = 18 \times 72 / 32 = 40.5$$

$$\begin{aligned} \therefore \text{Speed of gear C} &= x + y = 40.5 + 18 \\ &= + 58.5 \text{ r.p.m.} \\ &= 58.5 \text{ r.p.m. in the direction} \\ &\text{of arm. } \mathbf{Ans.} \end{aligned}$$

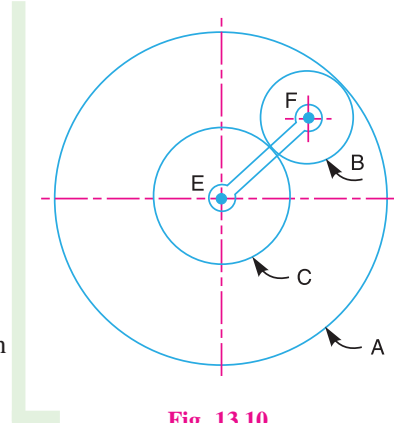

Fig. 13.10

Speed of gear B

Let d_A , d_B and d_C be the pitch circle diameters of gears A, B and C respectively. Therefore, from the geometry of Fig. 13.10,

$$d_B + \frac{d_C}{2} = \frac{d_A}{2} \quad \text{or} \quad 2 d_B + d_C = d_A$$

Since the number of teeth are proportional to their pitch circle diameters, therefore

$$2 T_B + T_C = T_A \quad \text{or} \quad 2 T_B + 32 = 72 \quad \text{or} \quad T_B = 20$$

$$\therefore \text{Speed of gear B} = y - x \times \frac{T_C}{T_B} = 18 - 40.5 \times \frac{32}{20} = - 46.8 \text{ r.p.m.}$$

$$= 46.8 \text{ r.p.m. in the opposite direction of arm. } \mathbf{Ans.}$$

Example 13.7. An epicyclic train of gears is arranged as shown in Fig.13.11. How many revolutions does the arm, to which the pinions B and C are attached, make :

1. when A makes one revolution clockwise and D makes half a revolution anticlockwise, and

2. when A makes one revolution clockwise and D is stationary ?

The number of teeth on the gears A and D are 40 and 90 respectively.

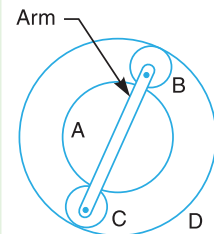

Fig. 13.11

Solution. Given : $T_A = 40$; $T_D = 90$

First of all, let us find the number of teeth on gears B and C (i.e. T_B and T_C). Let d_A , d_B , d_C and d_D be the pitch circle diameters of gears A, B, C and D respectively. Therefore from the geometry of the figure,

$$d_A + d_B + d_C = d_D \quad \text{or} \quad d_A + 2 d_B = d_D \quad \dots(\because d_B = d_C)$$

Since the number of teeth are proportional to their pitch circle diameters, therefore,

$$T_A + 2 T_B = T_D \quad \text{or} \quad 40 + 2 T_B = 90$$

$$\therefore T_B = 25, \quad \text{and} \quad T_C = 25 \quad \dots(\because T_B = T_C)$$





The table of motions is given below :

Table 13.6. Table of motions.

Step No.	Conditions of motion	Revolutions of elements			
		Arm	Gear A	Compound gear B-C	Gear D
1.	Arm fixed, gear A rotates through - 1 revolution (<i>i.e.</i> 1 rev. clockwise)	0	- 1	$+\frac{T_A}{T_B}$	$+\frac{T_A}{T_B} \times \frac{T_B}{T_D} = +\frac{T_A}{T_D}$
2.	Arm fixed, gear A rotates through - x revolutions	0	- x	$+x \times \frac{T_A}{T_B}$	$+x \times \frac{T_A}{T_D}$
3.	Add - y revolutions to all elements	- y	- y	- y	- y
4.	Total motion	- y	- $x - y$	$x \times \frac{T_A}{T_B} - y$	$x \times \frac{T_A}{T_D} - y$

1. Speed of arm when A makes 1 revolution clockwise and D makes half revolution anticlockwise

Since the gear A makes 1 revolution clockwise, therefore from the fourth row of the table,

$$-x - y = -1 \quad \text{or} \quad x + y = 1 \quad \dots(i)$$

Also, the gear D makes half revolution anticlockwise, therefore

$$x \times \frac{T_A}{T_D} - y = \frac{1}{2} \quad \text{or} \quad x \times \frac{40}{90} - y = \frac{1}{2}$$

$$\therefore 40x - 90y = 45 \quad \text{or} \quad x - 2.25y = 1.125 \quad \dots(ii)$$

From equations (i) and (ii), $x = 1.04$ and $y = -0.04$

$$\begin{aligned} \therefore \text{Speed of arm} &= -y = -(-0.04) = +0.04 \\ &= 0.04 \text{ revolution anticlockwise } \mathbf{Ans.} \end{aligned}$$

2. Speed of arm when A makes 1 revolution clockwise and D is stationary

Since the gear A makes 1 revolution clockwise, therefore from the fourth row of the table,

$$-x - y = -1 \quad \text{or} \quad x + y = 1 \quad \dots(iii)$$

Also the gear D is stationary, therefore

$$x \times \frac{T_A}{T_D} - y = 0 \quad \text{or} \quad x \times \frac{40}{90} - y = 0$$

$$\therefore 40x - 90y = 0 \quad \text{or} \quad x - 2.25y = 0 \quad \dots(iv)$$

From equations (iii) and (iv),

$$x = 0.692 \quad \text{and} \quad y = 0.308$$

$$\therefore \text{Speed of arm} = -y = -0.308 = 0.308 \text{ revolution clockwise } \mathbf{Ans.}$$





Example 13.8. In an epicyclic gear train, the internal wheels A and B and compound wheels C and D rotate independently about axis O. The wheels E and F rotate on pins fixed to the arm G. E gears with A and C and F gears with B and D. All the wheels have the same module and the number of teeth are : $T_C = 28$; $T_D = 26$; $T_E = T_F = 18$.

1. Sketch the arrangement ; 2. Find the number of teeth on A and B ; 3. If the arm G makes 100 r.p.m. clockwise and A is fixed, find the speed of B ; and 4. If the arm G makes 100 r.p.m. clockwise and wheel A makes 10 r.p.m. counter clockwise ; find the speed of wheel B.

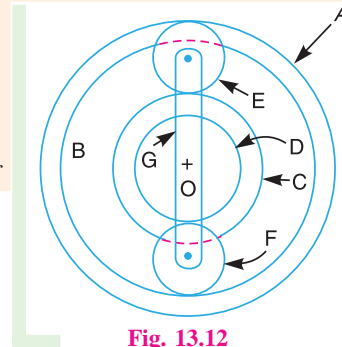

Solution. Given : $T_C = 28$; $T_D = 26$; $T_E = T_F = 18$

1. Sketch the arrangement

The arrangement is shown in Fig. 13.12.

2. Number of teeth on wheels A and B

Let T_A = Number of teeth on wheel A, and
 T_B = Number of teeth on wheel B.

If d_A, d_B, d_C, d_D, d_E and d_F are the pitch circle diameters of wheels A, B, C, D, E and F respectively, then from the geometry of Fig. 13.12,

$$d_A = d_C + 2 d_E$$

and

$$d_B = d_D + 2 d_F$$

Since the number of teeth are proportional to their pitch circle diameters, for the same module, therefore

$$T_A = T_C + 2 T_E = 28 + 2 \times 18 = 64 \quad \text{Ans.}$$

and

$$T_B = T_D + 2 T_F = 26 + 2 \times 18 = 62 \quad \text{Ans.}$$

3. Speed of wheel B when arm G makes 100 r.p.m. clockwise and wheel A is fixed

First of all, the table of motions is drawn as given below :

Table 13.7. Table of motions.

Step No.	Conditions of motion	Revolutions of elements					
		Arm G	Wheel A	Wheel E	Compound wheel C-D	Wheel F	Wheel B
1.	Arm fixed- wheel A rotates through + 1 revolution (i.e. 1 rev. anticlockwise)	0	+ 1	$+\frac{T_A}{T_E}$	$-\frac{T_A}{T_E} \times \frac{T_E}{T_C}$ $= -\frac{T_A}{T_C}$	$+\frac{T_A}{T_C} \times \frac{T_D}{T_F}$	$+\frac{T_A}{T_C} \times \frac{T_D}{T_F} \times \frac{T_F}{T_B}$ $= +\frac{T_A}{T_C} \times \frac{T_D}{T_B}$
2.	Arm fixed-wheel A rotates through + x revolutions	0	+ x	$+x \times \frac{T_A}{T_E}$	$-x \times \frac{T_A}{T_C}$	$+x \times \frac{T_A}{T_C} \times \frac{T_D}{T_F}$	$+x \times \frac{T_A}{T_C} \times \frac{T_D}{T_B}$
3.	Add + y revolutions to all elements	+ y	+ y	+ y	+ y	+ y	+ y
4.	Total motion	+ y	x + y	$y + x \times \frac{T_A}{T_E}$	$y - x \times \frac{T_A}{T_C}$	$y + x \times \frac{T_A}{T_C} \times \frac{T_D}{T_F}$	$y + x \times \frac{T_A}{T_C} \times \frac{T_D}{T_B}$





Since the arm G makes 100 r.p.m. clockwise, therefore from the fourth row of the table,

$$y = -100 \quad \dots(i)$$

Also, the wheel A is fixed, therefore from the fourth row of the table,

$$x + y = 0 \quad \text{or} \quad x = -y = 100 \quad \dots(ii)$$

$$\begin{aligned} \therefore \text{Speed of wheel } B &= y + x \times \frac{T_A}{T_C} \times \frac{T_D}{T_B} = -100 + 100 \times \frac{64}{28} \times \frac{26}{62} = -100 + 95.8 \text{ r.p.m.} \\ &= -4.2 \text{ r.p.m.} = 4.2 \text{ r.p.m. clockwise } \text{Ans.} \end{aligned}$$

4. Speed of wheel B when arm G makes 100 r.p.m. clockwise and wheel A makes 10 r.p.m. counter clockwise

Since the arm G makes 100 r.p.m. clockwise, therefore from the fourth row of the table

$$y = -100 \quad \dots(iii)$$

Also the wheel A makes 10 r.p.m. counter clockwise, therefore from the fourth row of the table,

$$x + y = 10 \quad \text{or} \quad x = 10 - y = 10 + 100 = 110 \quad \dots(iv)$$

$$\begin{aligned} \therefore \text{Speed of wheel } B &= y + x \times \frac{T_A}{T_C} \times \frac{T_D}{T_B} = -100 + 110 \times \frac{64}{28} \times \frac{26}{62} = -100 + 105.4 \text{ r.p.m.} \\ &= +5.4 \text{ r.p.m.} = 5.4 \text{ r.p.m. counter clockwise } \text{Ans.} \end{aligned}$$

Example 13.9. In an epicyclic gear of the 'sun and planet' type shown in Fig. 13.13, the pitch circle diameter of the internally toothed ring is to be 224 mm and the module 4 mm. When the ring D is stationary, the spider A , which carries three planet wheels C of equal size, is to make one revolution in the same sense as the sunwheel B for every five revolutions of the driving spindle carrying the sunwheel B . Determine suitable numbers of teeth for all the wheels.

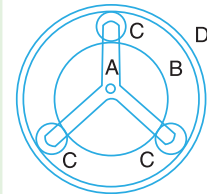

Fig. 13.13

Solution. Given : $d_D = 224 \text{ mm}$; $m = 4 \text{ mm}$; $N_A = N_B / 5$

Let T_B , T_C and T_D be the number of teeth on the sun wheel B , planet wheels C and the internally toothed ring D . The table of motions is given below :

Table 13.8. Table of motions.

Step No.	Conditions of motion	Revolutions of elements			
		Spider A	Sun wheel B	Planet wheel C	Internal gear D
1.	Spider A fixed, sun wheel B rotates through + 1 revolution (i.e. 1 rev. anticlockwise)	0	+ 1	$-\frac{T_B}{T_C}$	$-\frac{T_B}{T_C} \times \frac{T_C}{T_D} = -\frac{T_B}{T_D}$
2.	Spider A fixed, sun wheel B rotates through + x revolutions	0	+ x	$-x \times \frac{T_B}{T_C}$	$-x \times \frac{T_B}{T_D}$
3.	Add + y revolutions to all elements	+ y	+ y	+ y	+ y
4.	Total motion	+ y	x + y	$y - x \times \frac{T_B}{T_C}$	$y - x \times \frac{T_B}{T_D}$





448 • Theory of Machines

We know that when the sun wheel B makes + 5 revolutions, the spider A makes + 1 revolution. Therefore from the fourth row of the table,

$$y = + 1 ; \text{ and } x + y = + 5$$

$$\therefore x = 5 - y = 5 - 1 = 4$$

Since the internally toothed ring D is stationary, therefore from the fourth row of the table,

$$y - x \times \frac{T_B}{T_D} = 0$$

or
$$1 - 4 \times \frac{T_B}{T_D} = 0$$

$$\therefore \frac{T_B}{T_D} = \frac{1}{4} \quad \text{or} \quad T_D = 4 T_B \quad \dots(i)$$

We know that $T_D = d_D / m = 224 / 4 = 56$ **Ans.**

$\therefore T_B = T_D / 4 = 56 / 4 = 14$ **Ans.** ...[From equation (i)]

Let d_B, d_C and d_D be the pitch circle diameters of sun wheel B , planet wheels C and internally toothed ring D respectively. Assuming the pitch of all the gears to be same, therefore from the geometry of Fig. 13.13,

$$d_B + 2 d_C = d_D$$

Since the number of teeth are proportional to their pitch circle diameters, therefore

$$T_B + 2 T_C = T_D \quad \text{or} \quad 14 + 2 T_C = 56$$

$\therefore T_C = 21$ **Ans.**

Example 13.10. Two shafts A and B are co-axial. A gear C (50 teeth) is rigidly mounted on shaft A . A compound gear $D-E$ gears with C and an internal gear G . D has 20 teeth and gears with C and E has 35 teeth and gears with an internal gear G . The gear G is fixed and is concentric with the shaft axis. The compound gear $D-E$ is mounted on a pin which projects from an arm keyed to the shaft B . Sketch the arrangement and find the number of teeth on internal gear G assuming that all gears have the same module. If the shaft A rotates at 110 r.p.m., find the speed of shaft B .

Solution. Given : $T_C = 50 ; T_D = 20 ; T_E = 35 ; N_A = 110$ r.p.m.

The arrangement is shown in Fig. 13.14.

Number of teeth on internal gear G

Let d_C, d_D, d_E and d_G be the pitch circle diameters of gears C, D, E and G respectively. From the geometry of the figure,

$$\frac{d_G}{2} = \frac{d_C}{2} + \frac{d_D}{2} + \frac{d_E}{2}$$

or
$$d_G = d_C + d_D + d_E$$

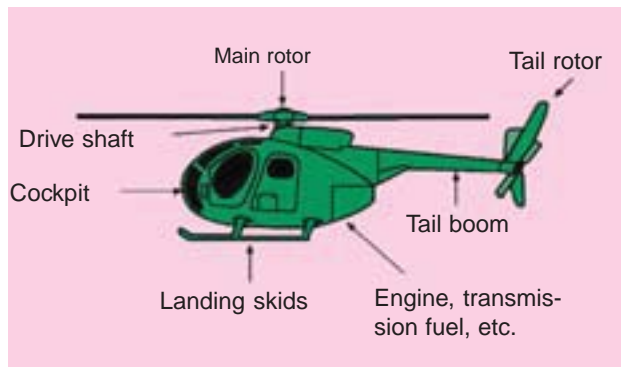

Power transmission in a helicopter is essentially through gear trains.

Note : This picture is given as additional information and is not a direct example of the current chapter.





Let T_C , T_D , T_E and T_G be the number of teeth on gears C , D , E and G respectively. Since all the gears have the same module, therefore number of teeth are proportional to their pitch circle diameters.

$$\therefore T_G = T_C + T_D + T_E = 50 + 20 + 35 = 105 \text{ Ans.}$$

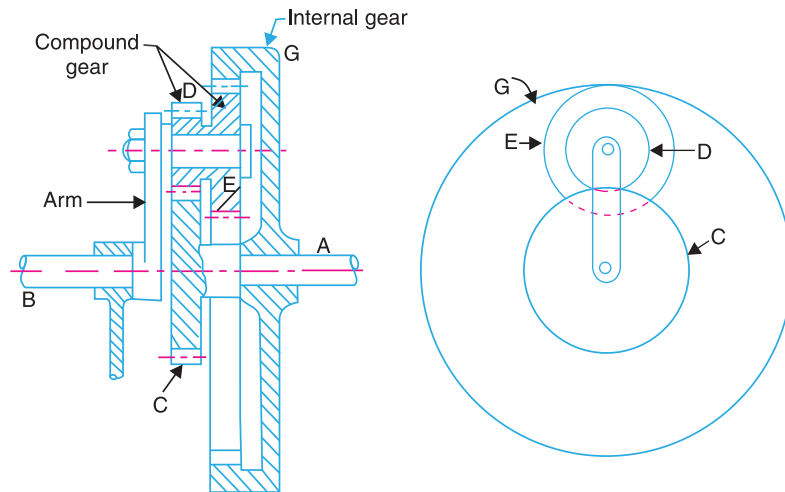

Fig. 13.14

Speed of shaft B

The table of motions is given below :

Table 13.9. Table of motions.

Step No.	Conditions of motion	Revolutions of elements			
		Arm	Gear C (or shaft A)	Compound gear D-E	Gear G
1.	Arm fixed - gear C rotates through + 1 revolution	0	+ 1	$-\frac{T_C}{T_D}$	$-\frac{T_C}{T_D} \times \frac{T_E}{T_G}$
2.	Arm fixed - gear C rotates through + x revolutions	0	+ x	$-x \times \frac{T_C}{T_D}$	$-x \times \frac{T_C}{T_D} \times \frac{T_E}{T_G}$
3.	Add + y revolutions to all elements	+ y	+ y	+ y	+ y
4.	Total motion	+ y	x + y	$y - x \times \frac{T_C}{T_D}$	$y - x \times \frac{T_C}{T_D} \times \frac{T_E}{T_G}$

Since the gear G is fixed, therefore from the fourth row of the table,

$$y - x \times \frac{T_C}{T_D} \times \frac{T_E}{T_G} = 0 \quad \text{or} \quad y - x \times \frac{50}{20} \times \frac{35}{105} = 0$$

$$\therefore y - \frac{5}{6}x = 0 \quad \dots(i)$$





450 • Theory of Machines

Since the gear *C* is rigidly mounted on shaft *A*, therefore speed of gear *C* and shaft *A* is same. We know that speed of shaft *A* is 110 r.p.m., therefore from the fourth row of the table,

$$x + y = 100 \quad \dots(ii)$$

From equations (i) and (ii), $x = 60$, and $y = 50$

∴ Speed of shaft *B* = Speed of arm = $+y = 50$ r.p.m. anticlockwise **Ans.**

Example 13.11. Fig. 13.15 shows diagrammatically a compound epicyclic gear train. Wheels *A*, *D* and *E* are free to rotate independently on spindle *O*, while *B* and *C* are compound and rotate together on spindle *P*, on the end of arm *OP*. All the teeth on different wheels have the same module. *A* has 12 teeth, *B* has 30 teeth and *C* has 14 teeth cut externally. Find the number of teeth on wheels *D* and *E* which are cut internally.

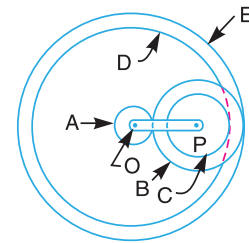

Fig. 13.15

If the wheel *A* is driven clockwise at 1 r.p.s. while *D* is driven counter clockwise at 5 r.p.s., determine the magnitude and direction of the angular velocities of arm *OP* and wheel *E*.

Solution. Given : $T_A = 12$; $T_B = 30$; $T_C = 14$; $N_A = 1$ r.p.s. ; $N_D = 5$ r.p.s.

Number of teeth on wheels *D* and *E*

Let T_D and T_E be the number of teeth on wheels *D* and *E* respectively. Let d_A, d_B, d_C, d_D and d_E be the pitch circle diameters of wheels *A*, *B*, *C*, *D* and *E* respectively. From the geometry of the figure,

$$d_E = d_A + 2d_B \quad \text{and} \quad d_D = d_E - (d_B - d_C)$$

Since the number of teeth are proportional to their pitch circle diameters for the same module, therefore

$$T_E = T_A + 2T_B = 12 + 2 \times 30 = 72 \quad \text{Ans.}$$

and

$$T_D = T_E - (T_B - T_C) = 72 - (30 - 14) = 56 \quad \text{Ans.}$$

Magnitude and direction of angular velocities of arm *OP* and wheel *E*

The table of motions is drawn as follows :

Table 13.10. Table of motions.

Step No.	Conditions of motion	Revolutions of elements				
		Arm	Wheel A	Compound wheel B-C	Wheel D	Wheel E
1.	Arm fixed A rotated through - 1 revolution (i.e. 1 revolution clockwise)	0	- 1	$+\frac{T_A}{T_B}$	$+\frac{T_A}{T_B} \times \frac{T_C}{T_D}$	$+\frac{T_A}{T_B} \times \frac{T_B}{T_E}$ $= +\frac{T_A}{T_E}$
2.	Arm fixed-wheel A rotated through - <i>x</i> revolutions	0	- <i>x</i>	$+x \times \frac{T_A}{T_B}$	$+x \times \frac{T_A}{T_B} \times \frac{T_C}{T_D}$	$+x \times \frac{T_A}{T_E}$
3.	Add - <i>y</i> revolutions to all elements	- <i>y</i>	- <i>y</i>	- <i>y</i>	- <i>y</i>	- <i>y</i>
4.	Total motion	- <i>y</i>	- <i>x</i> - <i>y</i>	$x \times \frac{T_A}{T_B} - y$	$x \times \frac{T_A}{T_B} \times \frac{T_C}{T_D} - y$	$x \times \frac{T_A}{T_E} - y$





Since the wheel A makes 1 r.p.s. clockwise, therefore from the fourth row of the table,

$$-x - y = -1 \quad \text{or} \quad x + y = 1 \quad \dots(i)$$

Also, the wheel D makes 5 r.p.s. counter clockwise, therefore

$$x \times \frac{T_A}{T_B} \times \frac{T_C}{T_D} - y = 5 \quad \text{or} \quad x \times \frac{12}{30} \times \frac{14}{56} - y = 5$$

$$\therefore 0.1x - y = 5 \quad \dots(ii)$$

From equations (i) and (ii),

$$x = 5.45 \quad \text{and} \quad y = -4.45$$

\therefore Angular velocity of arm OP

$$= -y = -(-4.45) = 4.45 \text{ r.p.s}$$

$$= 4.45 \times 2\pi = 27.964 \text{ rad/s (counter clockwise) Ans.}$$

and angular velocity of wheel $E = x \times \frac{T_A}{T_E} - y = 5.45 \times \frac{12}{72} - (-4.45) = 5.36 \text{ r.p.s.}$

$$= 5.36 \times 2\pi = 33.68 \text{ rad/s (counter clockwise) Ans.}$$

Example 13.12. An internal wheel B with 80 teeth is keyed to a shaft F . A fixed internal wheel C with 82 teeth is concentric with B . A compound wheel $D-E$ gears with the two internal wheels; D has 28 teeth and gears with C while E gears with B . The compound wheels revolve freely on a pin which projects from a disc keyed to a shaft A co-axial with F . If the wheels have the same pitch and the shaft A makes 800 r.p.m., what is the speed of the shaft F ? Sketch the arrangement.



Helicopter

Note : This picture is given as additional information and is not a direct example of the current chapter.

Solution. Given : $T_B = 80$; $T_C = 82$; $T_D = 28$; $N_A = 500 \text{ r.p.m.}$

The arrangement is shown in Fig. 13.16.

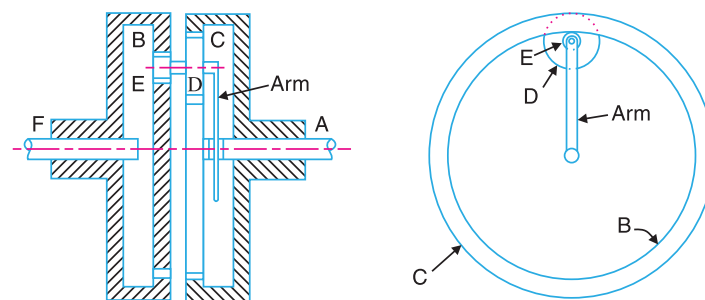

Fig. 13.16

First of all, let us find out the number of teeth on wheel E (T_E). Let d_B , d_C , d_D and d_E be the pitch circle diameter of wheels B , C , D and E respectively. From the geometry of the figure,

$$d_B = d_C - (d_D - d_E)$$





452 • Theory of Machines

or

$$d_E = d_B + d_D - d_C$$

Since the number of teeth are proportional to their pitch circle diameters for the same pitch, therefore

$$T_E = T_B + T_D - T_C = 80 + 28 - 82 = 26$$

The table of motions is given below :

Table 13.11. Table of motions.

Step No.	Conditions of motion	Revolutions of elements			
		Arm (or shaft A)	Wheel B (or shaft F)	Compound gear D-E	Wheel C
1.	Arm fixed - wheel B rotated through + 1 revolution (i.e. 1 revolution anticlockwise)	0	+ 1	$+\frac{T_B}{T_E}$	$+\frac{T_B}{T_E} \times \frac{T_D}{T_C}$
2.	Arm fixed - wheel B rotated through + x revolutions	0	+ x	$+x \times \frac{T_B}{T_E}$	$+x \times \frac{T_B}{T_E} \times \frac{T_D}{T_C}$
3.	Add + y revolutions to all elements	+ y	+ y	+ y	+ y
4.	Total motion	+ y	x + y	$y + x \times \frac{T_B}{T_E}$	$y + x \times \frac{T_B}{T_E} \times \frac{T_D}{T_C}$

Since the wheel C is fixed, therefore from the fourth row of the table,

$$y + x \times \frac{T_B}{T_E} \times \frac{T_D}{T_C} = 0 \quad \text{or} \quad y + x \times \frac{80}{26} \times \frac{28}{82} = 0$$

$$\therefore y + 1.05x = 0 \quad \dots(i)$$

Also, the shaft A (or the arm) makes 800 r.p.m., therefore from the fourth row of the table,

$$y = 800 \quad \dots(ii)$$

From equations (i) and (ii),

$$x = -762$$

$$\therefore \text{Speed of shaft } F = \text{Speed of wheel } B = x + y = -762 + 800 = +38 \text{ r.p.m.}$$

$$= 38 \text{ r.p.m. (anticlockwise) Ans.}$$

Example 13.13. Fig. 13.17 shows an epicyclic gear train known as Ferguson's paradox. Gear A is fixed to the frame and is, therefore, stationary. The arm B and gears C and D are free to rotate on the shaft S. Gears A, C and D have 100, 101 and 99 teeth respectively. The planet gear has 20 teeth. The pitch circle diameters of all are the same so that the planet gear P meshes with all of them. Determine the revolutions of gears C and D for one revolution of the arm B.

Solution. Given : $T_A = 100$; $T_C = 101$; $T_D = 99$; $T_P = 20$

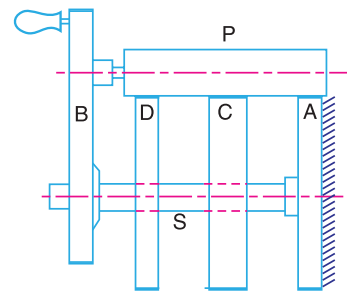

Fig. 13.17





The table of motions is given below :

Table 13.12. Table of motions.

Step No.	Conditions of motion	Revolutions of elements			
		Arm B	Gear A	Gear C	Gear D
1.	Arm B fixed, gear A rotated through + 1 revolution (i.e. 1 revolution anticlockwise)	0	+ 1	$+\frac{T_A}{T_C}$	$+\frac{T_A}{T_C} \times \frac{T_C}{T_D} = +\frac{T_A}{T_D}$
2.	Arm B fixed, gear A rotated through + x revolutions	0	+ x	$+x \times \frac{T_A}{T_C}$	$+x \times \frac{T_A}{T_D}$
3.	Add + y revolutions to all elements	+ y	+ y	+ y	+ y
4.	Total motion	+ y	x + y	$y + x \times \frac{T_A}{T_C}$	$y + x \times \frac{T_A}{T_D}$

The arm B makes one revolution, therefore

$$y = 1$$

Since the gear A is fixed, therefore from the fourth row of the table,

$$x + y = 0 \quad \text{or} \quad x = -y = -1$$

Let N_C and N_D = Revolutions of gears C and D respectively.

From the fourth row of the table, the revolutions of gear C,

$$N_C = y + x \times \frac{T_A}{T_C} = 1 - 1 \times \frac{100}{101} = +\frac{1}{101} \text{ Ans.}$$

and the revolutions of gear D,

$$N_D = y + x \times \frac{T_A}{T_D} = 1 - \frac{100}{99} = -\frac{1}{99} \text{ Ans.}$$

From above we see that for one revolution of the arm B, the gear C rotates through 1/101 revolutions in the same direction and the gear D rotates through 1/99 revolutions in the opposite direction.

Example 13.14. In the gear drive as shown in Fig. 13.18, the driving shaft A rotates at 300 r.p.m. in the clockwise direction, when seen from left hand. The shaft B is the driven shaft. The casing C is held stationary. The wheels E and H are keyed to the central vertical spindle and wheel F can rotate freely on this spindle. The wheels K and L are rigidly fixed to each other and rotate together freely on a pin fitted on the underside of F. The wheel L meshes with internal teeth on the casing C. The numbers of teeth on the different wheels are indicated within brackets in Fig. 13.18.

Find the number of teeth on wheel C and the speed and direction of rotation of shaft B.

Solution. Given : $N_A = 300$ r.p.m. (clockwise) ;
 $T_D = 40$; $T_B = 30$; $T_F = 50$; $T_G = 80$; $T_H = 40$; $T_K = 20$; $T_L = 30$

In the arrangement shown in Fig. 13.18, the wheels D and G are auxiliary gears and do not form a part of the epicyclic gear train.

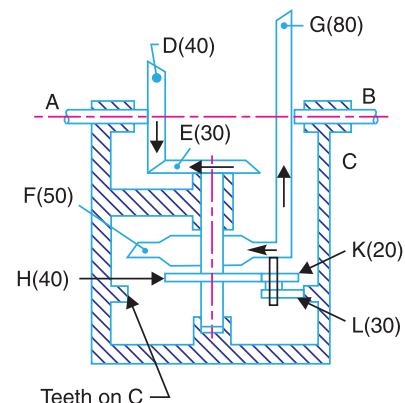

Fig. 13.18





454 • Theory of Machines

Speed of wheel E , $N_E = N_A \times \frac{T_D}{T_E} = 300 \times \frac{40}{30} = 400$ r.p.m. (clockwise)

Number of teeth on wheel C

Let T_C = Number of teeth on wheel C.

Assuming the same module for all teeth and since the pitch circle diameter is proportional to the number of teeth ; therefore from the geometry of Fig.13.18,

$$T_C = T_H + T_K + T_L = 40 + 20 + 30 = 90 \text{ Ans.}$$

Speed and direction of rotation of shaft B

The table of motions is given below. The wheel F acts as an arm.

Table 13.13. Table of motions.

Step No.	Conditions of motion	Revolutions of elements				
		Arm or wheel F	Wheel E	Wheel H	Compound wheel K-L	Wheel C
1.	Arm fixed-wheel E rotated through -1 revolution (<i>i.e.</i> 1 revolution clockwise)	0	-1	-1 ($\because E$ and H are on the same shaft)	$+\frac{T_H}{T_K}$	$+\frac{T_H}{T_K} \times \frac{T_L}{T_C}$
2.	Arm fixed-wheel E rotated through $-x$ revolutions	0	$-x$	$-x$	$+x \times \frac{T_H}{T_K}$	$+x \times \frac{T_H}{T_K} \times \frac{T_L}{T_C}$
3.	Add $-y$ revolutions to all elements	$-y$	$-y$	$-y$	$-y$	$-y$
4.	Total motion	$-y$	$-x-y$	$-x-y$	$x \times \frac{T_H}{T_K} - y$	$x \times \frac{T_H}{T_K} \times \frac{T_L}{T_C} - y$

Since the speed of wheel E is 400 r.p.m. (clockwise), therefore from the fourth row of the table,

$$-x - y = -400 \quad \text{or} \quad x + y = 400 \quad \dots(i)$$

Also the wheel C is fixed, therefore

$$x \times \frac{T_H}{T_K} \times \frac{T_L}{T_C} - y = 0$$

or $x \times \frac{40}{20} \times \frac{30}{90} - y = 0$

$$\therefore \frac{2x}{3} - y = 0 \quad \dots(ii)$$

From equations (i) and (ii),

$$x = 240 \quad \text{and} \quad y = 160$$

\therefore Speed of wheel F , $N_F = -y = -160$ r.p.m.

Since the wheel F is in mesh with wheel G , therefore speed of wheel G or speed of shaft B

$$= -N_F \times \frac{T_F}{T_G} = -\left(-160 \times \frac{50}{80}\right) = 100 \text{ r.p.m.}$$

$\dots(\because$ Wheel G will rotate in opposite direction to that of wheel F)
 $= 100$ r.p.m. anticlockwise *i.e.* in opposite direction of shaft A . **Ans.**





Example 13.15. Fig. 13.19 shows a compound epicyclic gear in which the casing C contains an epicyclic train and this casing is inside the larger casing D.

Determine the velocity ratio of the output shaft B to the input shaft A when the casing D is held stationary. The number of teeth on various wheels are as follows :

Wheel on A = 80 ; Annular wheel on B = 160 ; Annular wheel on C = 100 ; Annular wheel on D = 120 ; Small pinion on F = 20 ; Large pinion on F = 66.

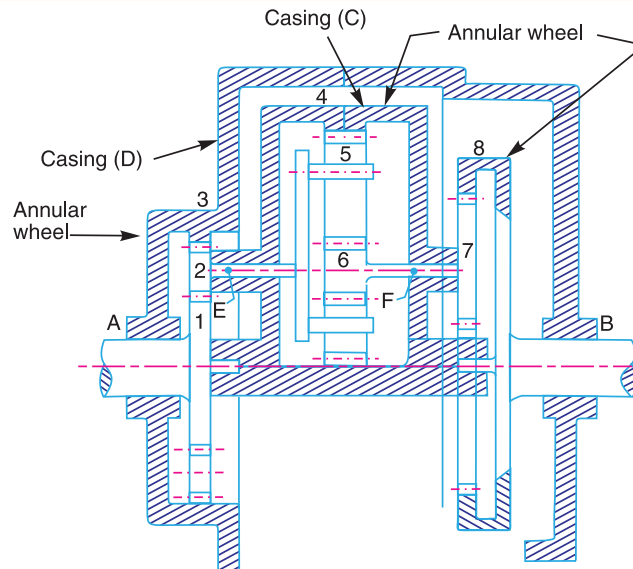

Fig. 13.19

Solution. Given : $T_1 = 80$; $T_8 = 160$; $T_4 = 100$; $T_3 = 120$; $T_6 = 20$; $T_7 = 66$

First of all, let us consider the train of wheel 1 (on A), wheel 2 (on E), annular wheel 3 (on D) and the arm *i.e.* casing C. Since the pitch circle diameters of wheels are proportional to the number of teeth, therefore from the geometry of Fig. 13.19,

$$T_1 + 2 T_2 = T_3 \quad \text{or} \quad 80 + 2 T_2 = 120$$

$$\therefore T_2 = 20$$

The table of motions for the train considered is given below :

Table 13.14. Table of motions.

Step No.	Conditions of motion	Revolutions of elements			
		Arm	Wheel 1	Wheel 2	Wheel 3
1.	Arm fixed - wheel 1 rotated through + 1 revolution (anticlockwise)	0	+ 1	$-\frac{T_1}{T_2}$	$-\frac{T_1}{T_2} \times \frac{T_2}{T_3} = -\frac{T_1}{T_3}$
2.	Arm fixed - wheel 1 rotated through + x revolutions	0	+ x	$-x \times \frac{T_1}{T_2}$	$-x \times \frac{T_1}{T_3}$
3.	Add + y revolutions to all elements	+ y	+ y	+ y	+ y
4.	Total motion	y	x + y	$y - x \times \frac{T_1}{T_2}$	$y - x \times \frac{T_1}{T_3}$





456 • Theory of Machines

Let us assume that wheel 1 makes 1 r.p.s. anticlockwise.

$$\therefore x + y = 1 \quad \dots(i)$$

Also the wheel 3 is stationary, therefore from the fourth row of the table,

$$y - x \times \frac{T_1}{T_3} = 0 \quad \text{or} \quad y - x \times \frac{80}{120} = 0$$

$$\therefore y - \frac{2}{3}x = 0 \quad \dots(ii)$$

From equations (i) and (ii), $x = 0.6$, and $y = 0.4$

\therefore Speed of arm or casing $C = y = 0.4$ r.p.s.

$$\begin{aligned} \text{and speed of wheel 2 or arm } E &= y - x \times \frac{T_1}{T_2} = 0.4 - 0.6 \times \frac{80}{20} = -2 \text{ r.p.s.} \\ &= 2 \text{ r.p.s. (clockwise)} \end{aligned}$$

Let us now consider the train of annular wheel 4 (on C), wheel 5 (on E), wheel 6 (on F) and arm E. We know that

$$T_6 + 2T_5 = T_4 \quad \text{or} \quad 20 + 2T_5 = 100$$

$$\therefore T_5 = 40$$

The table of motions is given below :

Table 13.15. Table of motions.

Step No.	Conditions of motion	Revolutions of elements			
		Arm E or wheel 2	Wheel 6	Wheel 5	Wheel 4
1.	Arm fixed, wheel 6 rotated through + 1 revolution	0	+ 1	$-\frac{T_6}{T_5}$	$-\frac{T_6}{T_5} \times \frac{T_5}{T_4} = -\frac{T_6}{T_4}$
2.	Arm fixed, wheel 6 rotated through + x_1 revolutions	0	x_1	$-x_1 \times \frac{T_6}{T_5}$	$-x_1 \times \frac{T_6}{T_4}$
3.	Add + y_1 revolutions to all elements	+ y_1	+ y_1	+ y_1	+ y_1
4.	Total motion	+ y_1	$x_1 + y_1$	$y_1 - x_1 \times \frac{T_6}{T_5}$	$y_1 - x_1 \times \frac{T_6}{T_4}$

We know that speed of arm E = Speed of wheel 2 in the first train

$$\therefore y_1 = -2 \quad \dots(iii)$$

Also speed of wheel 4 = Speed of arm or casing C in the first train

$$\therefore y_1 - x_1 \times \frac{T_6}{T_4} = 0.4 \quad \text{or} \quad -2 - x_1 \times \frac{20}{100} = 0.4 \quad \dots(iv)$$

$$\text{or} \quad x_1 = (-2 - 0.4) \frac{100}{20} = -12$$





∴ Speed of wheel 6 (or F)

$$= x_1 + y_1 = -12 - 2 = -14 \text{ r.p.s.} = 14 \text{ r.p.s. (clockwise)}$$

Now consider the train of wheels 6 and 7 (both on F), annular wheel 8 (on B) and the arm *i.e.* casing C . The table of motions is given below :

Table 13.16. Table of motions.

Step No.	Conditions of motion	Revolutions of elements		
		Arm	Wheel 8	Wheel 7
1.	Arm fixed, wheel 8 rotated through + 1 revolution	0	+ 1	$+\frac{T_8}{T_7}$
2.	Arm fixed, wheel 8 rotated through $+x_2$ revolutions	0	$+x_2$	$+x_2 \times \frac{T_8}{T_7}$
3.	Add $+y_2$ revolutions to all elements	$+y_2$	$+y_2$	$+y_2$
4.	Total motion	y_2	$x_2 + y_2$	$y_2 + x_2 \times \frac{T_8}{T_7}$

We know that the speed of C in the first train is 0.4 r.p.s., therefore

$$y_2 = 0.4 \quad \dots(v)$$

Also the speed of wheel 7 is equal to the speed of F or wheel 6 in the second train, therefore

$$y_2 + x_2 \times \frac{T_8}{T_7} = -14 \quad \text{or} \quad 0.4 + x_2 \times \frac{160}{66} = -14 \quad \dots(vi)$$

$$\therefore x_2 = (-14 - 0.4) \frac{66}{160} = -5.94$$

∴ Speed of wheel 8 or of the shaft B

$$x_2 + y_2 = -5.94 + 0.4 = -5.54 \text{ r.p.s.} = 5.54 \text{ r.p.s. (clockwise)}$$

We have already assumed that the speed of wheel 1 or the shaft A is 1 r.p.s. anticlockwise

∴ Velocity ratio of the output shaft B to the input shaft A

$$= -5.54 \text{ Ans.}$$

Note : The – ve sign shows that the two shafts A and B rotate in opposite directions.

13.10. Epicyclic Gear Train with Bevel Gears

The bevel gears are used to make a more compact epicyclic system and they permit a very high speed reduction with few gears. The useful application of the epicyclic gear train with bevel gears is found in Humpage's speed reduction gear and differential gear of an automobile as discussed below :

1. Humpage's speed reduction gear. The Humpage's speed reduction gear was originally designed as a substitute for back gearing of a lathe, but its use is now considerably extended to all kinds of workshop machines and also in electrical machinery. In Humpage's speed reduction gear, as shown in Fig. 13.20, the driving shaft X and the driven shaft Y are co-axial. The driving shaft carries a bevel gear A and driven shaft carries a bevel gear E . The bevel gear B meshes with gear A (also known as pinion) and a fixed gear C . The gear E meshes with gear D which is compound with gear B .





458 • Theory of Machines

This compound gear $B-D$ is mounted on the arm or spindle F which is rigidly connected with a hollow sleeve G . The sleeve revolves freely loose on the axes of the driving and driven shafts.

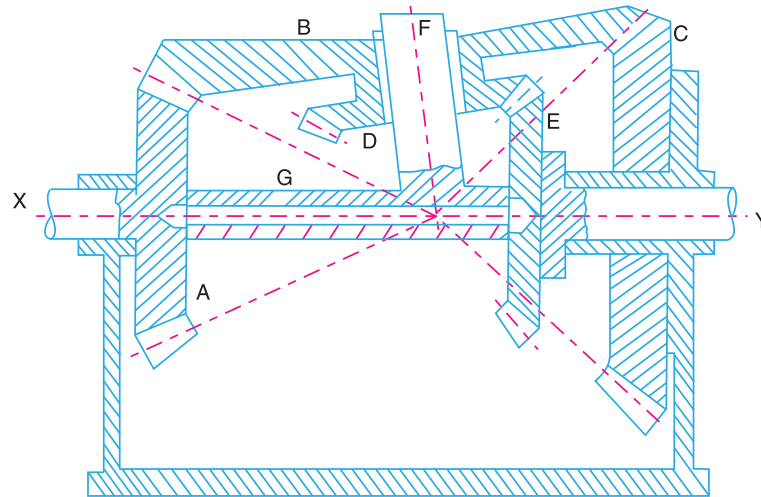

Fig. 13.20. Humpage's speed reduction gear.

2. Differential gear of an automobile. The differential gear used in the rear drive of an automobile is shown in Fig. 13.21. Its function is

- (a) to transmit motion from the engine shaft to the rear driving wheels, and
- (b) to rotate the rear wheels at different speeds while the automobile is taking a turn.

As long as the automobile is running on a straight path, the rear wheels are driven directly by the engine and speed of both the wheels is same. But when the automobile is taking a turn, the outer wheel will run faster than the * inner wheel because at that time the outer rear wheel has to cover more distance than the inner rear wheel. This is achieved by epicyclic gear train with bevel gears as shown in Fig. 13.21.

The bevel gear A (known as pinion) is keyed to the propeller shaft driven from the engine shaft through universal coupling. This gear A drives the gear B (known as crown gear) which rotates freely on the axle P . Two equal gears C and D are mounted on two separate parts P and Q of the rear axles respectively. These gears, in turn, mesh with equal pinions E and F which can rotate freely on the spindle provided on the arm attached to gear B .

When the automobile runs on a straight path, the gears C and D must rotate together. These gears are rotated through the spindle on the gear B . The gears E and F do not rotate on the spindle. But when the automobile is taking a turn, the inner rear wheel should have lesser speed than the outer rear wheel and due to relative speed of the inner and outer gears D and C , the gears E and F start rotating about the spindle axis and at the same time revolve about the axle axis.

Due to this epicyclic effect, the speed of the inner rear wheel decreases by a certain amount and the speed of the outer rear wheel increases, by the same amount. This may be well understood by drawing the table of motions as follows :

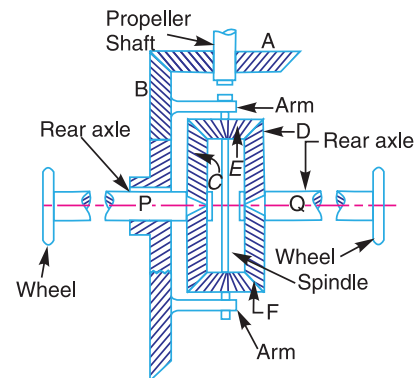

Fig. 13.21. Differential gear of an automobile.

* This difficulty does not arise with the front wheels as they are greatly used for steering purposes and are mounted on separate axles and can run freely at different speeds.





Table 13.17. Table of motions.

Step No.	Conditions of motion	Revolutions of elements			
		Gear B	Gear C	Gear E	Gear D
1.	Gear B fixed-Gear C rotated through + 1 revolution (i.e. 1 revolution anticlockwise)	0	+ 1	$+\frac{T_C}{T_E}$	$-\frac{T_C}{T_E} \times \frac{T_E}{T_D} = -1$ ($\because T_C = T_D$)
2.	Gear B fixed-Gear C rotated through + x revolutions	0	+ x	$+x \times \frac{T_C}{T_E}$	-x
3.	Add + y revolutions to all elements	+ y	+ y	+ y	+ y
4.	Total motion	+ y	x + y	$y + x \times \frac{T_C}{T_E}$	y - x

From the table, we see that when the gear B, which derives motion from the engine shaft, rotates at y revolutions, then the speed of inner gear D (or the rear axle Q) is less than y by x revolutions and the speed of the outer gear C (or the rear axle P) is greater than y by x revolutions. In other words, the two parts of the rear axle and thus the two wheels rotate at two different speeds. We also see from the table that the speed of gear B is the mean of speeds of the gears C and D.

Example 13.16. Two bevel gears A and B (having 40 teeth and 30 teeth) are rigidly mounted on two co-axial shafts X and Y. A bevel gear C (having 50 teeth) meshes with A and B and rotates freely on one end of an arm. At the other end of the arm is welded a sleeve and the sleeve is riding freely loose on the axes of the shafts X and Y. Sketch the arrangement.

If the shaft X rotates at 100 r.p.m. clockwise and arm rotates at 100 r.p.m. anticlockwise, find the speed of shaft Y.

Solution. Given : $T_A = 40$; $T_B = 30$; $T_C = 50$; $N_X = N_A = 100$ r.p.m. (clockwise) ; Speed of arm = 100 r.p.m. (anticlockwise)

The arrangement is shown in Fig. 13.22.

The table of motions is drawn as below :

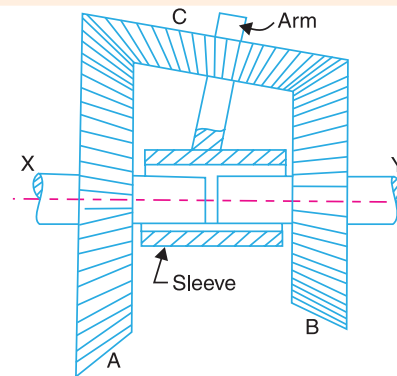

Fig. 13.22

Table 13.18. Table of motions.

Step No.	Conditions of motion	Revolutions of elements			
		Arm	Gear A	Gear C	Gear B
1.	Arm B fixed, gear A rotated through + 1 revolution (i.e. 1 revolution anticlockwise)	0	+ 1	$\pm \frac{T_A}{T_C}$	$-\frac{T_A}{T_C} \times \frac{T_C}{T_B} = -\frac{T_A}{T_B}$
2.	Arm B fixed, gear A rotated through + x revolutions	0	+ x	$\pm x \times \frac{T_A}{T_C}$	$-x \times \frac{T_A}{T_B}$
3.	Add + y revolutions to all elements	+ y	+ y	+ y	+ y
4.	Total motion	+ y	x + y	$y \pm x \times \frac{T_A}{T_C}$	$y - x \times \frac{T_A}{T_B}$

* The \pm sign is given to the motion of the wheel C because it is in a different plane. So we cannot indicate the direction of its motion specifically, i.e. either clockwise or anticlockwise.





460 • Theory of Machines

Since the speed of the arm is 100 r.p.m. anticlockwise, therefore from the fourth row of the table,

$$y = + 100$$

Also, the speed of the driving shaft X or gear A is 100 r.p.m. clockwise.

$$\therefore x + y = - 100 \quad \text{or} \quad x = - y - 100 = - 100 - 100 = - 200$$

\therefore Speed of the driven shaft *i.e.* shaft Y,

$$N_Y = \text{Speed of gear } B = y - x \times \frac{T_A}{T_B} = 100 - \left(- 200 \times \frac{40}{30} \right) \\ = + 366.7 \text{ r.p.m.} = 366.7 \text{ r.p.m. (anticlockwise) Ans.}$$

Example 13.17. In a gear train, as shown in Fig. 13.23, gear B is connected to the input shaft and gear F is connected to the output shaft. The arm A carrying the compound wheels D and E, turns freely on the output shaft. If the input speed is 1000 r.p.m. counter-clockwise when seen from the right, determine the speed of the output shaft under the following conditions :

1. When gear C is fixed, and 2. when gear C is rotated at 10 r.p.m. counter clockwise.

Solution. Given : $T_B = 20$; $T_C = 80$; $T_D = 60$; $T_E = 30$; $T_F = 32$; $N_B = 1000$ r.p.m. (counter-clockwise)

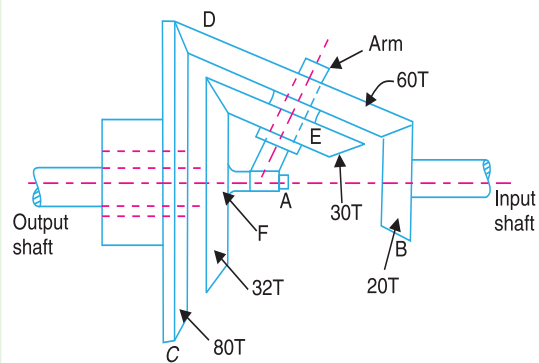

Fig. 13.23

The table of motions is given below :

Table 13.19. Table of motions.

Step No.	Conditions of motion	Revolutions of elements				
		Arm A	Gear B (or input shaft)	Compound wheel D-E	Gear C	Gear F (or output shaft)
1.	Arm fixed, gear B rotated through + 1 revolution (<i>i.e.</i> 1 revolution anticlockwise)	0	+ 1	$+\frac{T_B}{T_D}$	$-\frac{T_B}{T_D} \times \frac{T_D}{T_C}$ $= -\frac{T_B}{T_C}$	$-\frac{T_B}{T_D} \times \frac{T_E}{T_F}$
2.	Arm fixed, gear B rotated through + x revolutions	0	+ x	$+x \times \frac{T_B}{T_D}$	$-x \times \frac{T_B}{T_C}$	$-x \times \frac{T_B}{T_D} \times \frac{T_E}{T_F}$
3.	Add + y revolutions to all elements	+ y	+ y	+ y	+ y	+ y
4.	Total motion	+ y	x + y	$y + x \times \frac{T_B}{T_D}$	$y - x \times \frac{T_B}{T_C}$	$y - x \times \frac{T_B}{T_D} \times \frac{T_E}{T_F}$





1. Speed of the output shaft when gear C is fixed

Since the gear C is fixed, therefore from the fourth row of the table,

$$y - x \times \frac{T_B}{T_C} = 0 \quad \text{or} \quad y - x \times \frac{20}{80} = 0$$

$$\therefore y - 0.25x = 0 \quad \dots(i)$$

We know that the input speed (or the speed of gear B) is 1000 r.p.m. counter clockwise, therefore from the fourth row of the table,

$$x + y = + 1000 \quad \dots(ii)$$

From equations (i) and (ii), $x = + 800$, and $y = + 200$

$$\therefore \text{Speed of output shaft} = \text{Speed of gear } F = y - x \times \frac{T_B}{T_D} \times \frac{T_E}{T_F}$$

$$= 200 - 800 \times \frac{20}{80} \times \frac{30}{32} = 200 - 187.5 = 12.5 \text{ r.p.m.}$$

$$= 12.5 \text{ r.p.m. (counter clockwise) Ans.}$$

2. Speed of the output shaft when gear C is rotated at 10 r.p.m. counter clockwise

Since the gear C is rotated at 10 r.p.m. counter clockwise, therefore from the fourth row of the table,

$$y - x \times \frac{T_B}{T_C} = +10 \quad \text{or} \quad y - x \times \frac{20}{80} = 10$$

$$\therefore y - 0.25x = 10 \quad \dots(iii)$$

From equations (ii) and (iii),

$$x = 792, \quad \text{and} \quad y = 208$$

\therefore Speed of output shaft

$$= \text{Speed of gear } F = y - x \times \frac{T_B}{T_D} \times \frac{T_E}{T_F} = 208 - 792 \times \frac{20}{80} \times \frac{30}{32}$$

$$= 208 - 185.6 = 22.4 \text{ r.p.m.} = 22.4 \text{ r.p.m. (counter clockwise) Ans.}$$

Example 13.18. Fig. 13.24 shows a differential gear used in a motor car. The pinion A on the propeller shaft has 12 teeth and gears with the crown gear B which has 60 teeth. The shafts P and Q form the rear axles to which the road wheels are attached. If the propeller shaft rotates at 1000 r.p.m. and the road wheel attached to axle Q has a speed of 210 r.p.m. while taking a turn, find the speed of road wheel attached to axle P.

Solution. Given : $T_A = 12$; $T_B = 60$; $N_A = 1000$ r.p.m. ; $N_Q = N_D = 210$ r.p.m.

Since the propeller shaft or the pinion A rotates at 1000 r.p.m., therefore speed of crown gear B,

$$N_B = N_A \times \frac{T_A}{T_B} = 1000 \times \frac{12}{60} = 200 \text{ r.p.m.}$$

The table of motions is given below :

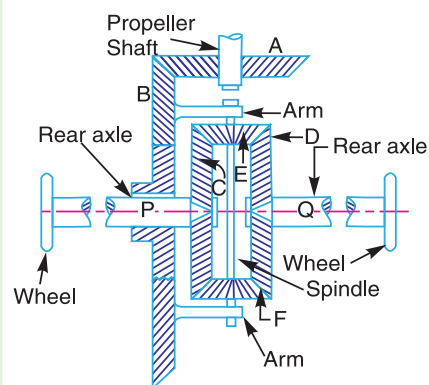

Fig. 13.24





Table 13.20. Table of motions.

Step No.	Conditions of motion	Revolutions of elements			
		Gear B	Gear C	Gear E	Gear D
1.	Gear B fixed-Gear C rotated through + 1 revolution (i.e. 1 revolution anticlockwise)	0	+ 1	$+\frac{T_C}{T_E}$	$-\frac{T_C}{T_E} \times \frac{T_E}{T_D} = -1$ ($\because T_C = T_D$)
2.	Gear B fixed-Gear C rotated through + x revolutions	0	+ x	$+x \times \frac{T_C}{T_E}$	- x
3.	Add + y revolutions to all elements	+ y	+ y	+ y	+ y
4.	Total motion	+ y	x + y	$y + x \times \frac{T_C}{T_E}$	y - x

Since the speed of gear B is 200 r.p.m., therefore from the fourth row of the table,

$$y = 200 \quad \dots(i)$$

Also, the speed of road wheel attached to axle Q or the speed of gear D is 210 r.p.m., therefore from the fourth row of the table,

$$y - x = 210 \quad \text{or} \quad x = y - 210 = 200 - 210 = -10$$

\therefore Speed of road wheel attached to axle P

$$= \text{Speed of gear C} = x + y$$

$$= -10 + 200 = 190 \text{ r.p.m. Ans.}$$

13.11. Torques in Epicyclic Gear Trains

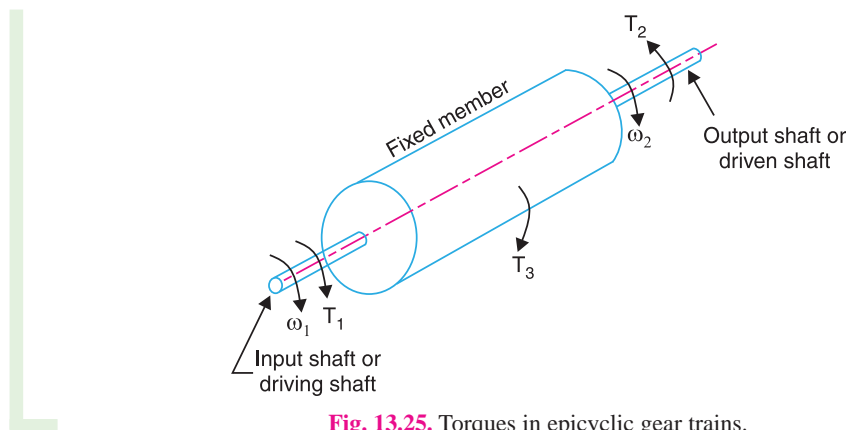

Fig. 13.25. Torques in epicyclic gear trains.

When the rotating parts of an epicyclic gear train, as shown in Fig. 13.25, have no angular acceleration, the gear train is kept in equilibrium by the three externally applied torques, viz.

1. Input torque on the driving member (T_1),
2. Output torque or resisting or load torque on the driven member (T_2),
3. Holding or braking or fixing torque on the fixed member (T_3).





The net torque applied to the gear train must be zero. In other words,

$$T_1 + T_2 + T_3 = 0 \quad \dots(i)$$

$$\therefore F_1 \cdot r_1 + F_2 \cdot r_2 + F_3 \cdot r_3 = 0 \quad \dots(ii)$$

where F_1 , F_2 and F_3 are the corresponding externally applied forces at radii r_1 , r_2 and r_3 .

Further, if ω_1 , ω_2 and ω_3 are the angular speeds of the driving, driven and fixed members respectively, and the friction be neglected, then the net kinetic energy dissipated by the gear train must be zero, *i.e.*

$$T_1 \cdot \omega_1 + T_2 \cdot \omega_2 + T_3 \cdot \omega_3 = 0 \quad \dots(iii)$$

But, for a fixed member, $\omega_3 = 0$

$$\therefore T_1 \cdot \omega_1 + T_2 \cdot \omega_2 = 0 \quad \dots(iv)$$

Notes : 1. From equations (i) and (iv), the holding or braking torque T_3 may be obtained as follows :

$$T_2 = -T_1 \times \frac{\omega_1}{\omega_2} \quad \dots[\text{From equation (iv)}]$$

and

$$T_3 = -(T_1 + T_2) \quad \dots[\text{From equation (i)}]$$

$$= T_1 \left(\frac{\omega_1}{\omega_2} - 1 \right) = T_1 \left(\frac{N_1}{N_2} - 1 \right)$$

2. When input shaft (or driving shaft) and output shaft (or driven shaft) rotate in the same direction, then the input and output torques will be in opposite directions. Similarly, when the input and output shafts rotate in opposite directions, then the input and output torques will be in the same direction.

Example 13.19. Fig. 13.26 shows an epicyclic gear train. Pinion A has 15 teeth and is rigidly fixed to the motor shaft. The wheel B has 20 teeth and gears with A and also with the annular fixed wheel E. Pinion C has 15 teeth and is integral with B (B, C being a compound gear wheel). Gear C meshes with annular wheel D, which is keyed to the machine shaft. The arm rotates about the same shaft on which A is fixed and carries the compound wheel B, C. If the motor runs at 1000 r.p.m., find the speed of the machine shaft. Find the torque exerted on the machine shaft, if the motor develops a torque of 100 N-m.

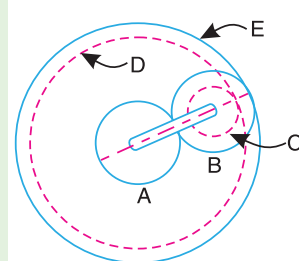

Fig. 13.26

Solution. Given : $T_A = 15$; $T_B = 20$; $T_C = 15$; $N_A = 1000$ r.p.m.; Torque developed by motor (or pinion A) = 100 N-m

First of all, let us find the number of teeth on wheels D and E. Let T_D and T_E be the number of teeth on wheels D and E respectively. Let d_A , d_B , d_C , d_D and d_E be the pitch circle diameters of wheels A, B, C, D and E respectively. From the geometry of the figure,

$$d_E = d_A + 2 d_B \quad \text{and} \quad d_D = d_E - (d_B - d_C)$$

Since the number of teeth are proportional to their pitch circle diameters, therefore,

$$T_E = T_A + 2 T_B = 15 + 2 \times 20 = 55$$

and

$$T_D = T_E - (T_B - T_C) = 55 - (20 - 15) = 50$$

Speed of the machine shaft

The table of motions is given below :





Table 13.21. Table of motions.

Step No.	Conditions of motion	Revolutions of elements				
		Arm	Pinion A	Compound wheel B-C	Wheel D	Wheel E
1.	Arm fixed-pinion A rotated through + 1 revolution (anticlockwise)	0	+ 1	$-\frac{T_A}{T_B}$	$-\frac{T_A}{T_B} \times \frac{T_C}{T_D}$	$-\frac{T_A}{T_B} \times \frac{T_B}{T_E} = -\frac{T_A}{T_E}$
2.	Arm fixed-pinion A rotated through + x revolutions	0	+ x	$-x \times \frac{T_A}{T_B}$	$-x \times \frac{T_A}{T_B} \times \frac{T_C}{T_D}$	$-x \times \frac{T_A}{T_E}$
3.	Add + y revolutions to all elements	+ y	+ y	+ y	+ y	+ y
4.	Total motion	+ y	x + y	$y - x \times \frac{T_A}{T_B}$	$y - x \times \frac{T_A}{T_B} \times \frac{T_C}{T_D}$	$y - x \times \frac{T_A}{T_E}$

We know that the speed of the motor or the speed of the pinion A is 1000 r.p.m. Therefore

$$x + y = 1000 \quad \dots(i)$$

Also, the annular wheel E is fixed, therefore

$$y - x \times \frac{T_A}{T_E} = 0 \quad \text{or} \quad y = x \times \frac{T_A}{T_E} = x \times \frac{15}{55} = 0.273 x \quad \dots(ii)$$

From equations (i) and (ii),

$$x = 786 \quad \text{and} \quad y = 214$$

∴ Speed of machine shaft = Speed of wheel D,

$$\begin{aligned} N_D &= y - x \times \frac{T_A}{T_B} \times \frac{T_C}{T_D} = 214 - 786 \times \frac{15}{20} \times \frac{15}{50} = +37.15 \text{ r.p.m.} \\ &= 37.15 \text{ r.p.m. (anticlockwise) Ans.} \end{aligned}$$

Torque exerted on the machine shaft

We know that

Torque developed by motor × Angular speed of motor

$$= \text{Torque exerted on machine shaft} \times \text{Angular speed of machine shaft}$$

or $100 \times \omega_A = \text{Torque exerted on machine shaft} \times \omega_D$

∴ Torque exerted on machine shaft

$$= 100 \times \frac{\omega_A}{\omega_D} = 100 \times \frac{N_A}{N_D} = 100 \times \frac{1000}{37.15} = 2692 \text{ N-m Ans.}$$





Example 13.20. An epicyclic gear train consists of a sun wheel S , a stationary internal gear E and three identical planet wheels P carried on a star-shaped planet carrier C . The size of different toothed wheels are such that the planet carrier C rotates at $1/5$ th of the speed of the sunwheel S . The minimum number of teeth on any wheel is 16. The driving torque on the sun wheel is 100 N-m . Determine : **1.** number of teeth on different wheels of the train, and **2.** torque necessary to keep the internal gear stationary.

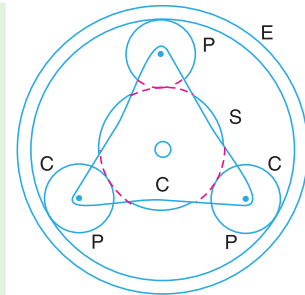

Fig. 13.27

Solution. Given : $N_C = \frac{N_S}{5}$

1. Number of teeth on different wheels

The arrangement of the epicyclic gear train is shown in Fig. 13.27. Let T_S and T_E be the number of teeth on the sun wheel S and the internal gear E respectively. The table of motions is given below :

Table 13.22. Table of motions.

Step No.	Conditions of motion	Revolutions of elements			
		Planet carrier C	Sun wheel S	Planet wheel P	Internal gear E
1.	Planet carrier C fixed, sunwheel S rotates through $+1$ revolution (<i>i.e.</i> 1 rev. anticlockwise)	0	$+1$	$-\frac{T_S}{T_P}$	$-\frac{T_S}{T_P} \times \frac{T_P}{T_E} = -\frac{T_S}{T_E}$
2.	Planet carrier C fixed, sunwheel S rotates through $+x$ revolutions	0	$+x$	$-x \times \frac{T_S}{T_P}$	$-x \times \frac{T_S}{T_E}$
3.	Add $+y$ revolutions to all elements	$+y$	$+y$	$+y$	$+y$
4.	Total motion	$+y$	$x+y$	$y - x \times \frac{T_S}{T_P}$	$y - x \times \frac{T_S}{T_E}$

We know that when the sunwheel S makes 5 revolutions, the planet carrier C makes 1 revolution. Therefore from the fourth row of the table,

$$y = 1, \quad \text{and} \quad x + y = 5 \quad \text{or} \quad x = 5 - y = 5 - 1 = 4$$

Since the gear E is stationary, therefore from the fourth row of the table,

$$y - x \times \frac{T_S}{T_E} = 0 \quad \text{or} \quad 1 - 4 \times \frac{T_S}{T_E} = 0 \quad \text{or} \quad \frac{T_S}{T_E} = \frac{1}{4}$$

$$\therefore T_E = 4T_S$$

Since the minimum number of teeth on any wheel is 16, therefore let us take the number of teeth on sunwheel,

$$T_S = 16$$

$$\therefore T_E = 4 T_S = 64 \text{ Ans.}$$

Let d_S , d_P and d_E be the pitch circle diameters of wheels S , P and E respectively. Now from the geometry of Fig. 13.27,

$$d_S + 2 d_P = d_E$$





466 • Theory of Machines

Assuming the module of all the gears to be same, the number of teeth are proportional to their pitch circle diameters.

$$T_S + 2 T_P = T_E \quad \text{or} \quad 16 + 2 T_P = 64 \quad \text{or} \quad T_P = 24 \text{ Ans.}$$

2. Torque necessary to keep the internal gear stationary

We know that

Torque on $S \times$ Angular speed of S

= Torque on $C \times$ Angular speed of C

$$100 \times \omega_S = \text{Torque on } C \times \omega_C$$

$$\therefore \text{Torque on } C = 100 \times \frac{\omega_S}{\omega_C} = 100 \times \frac{N_S}{N_C} = 100 \times 5 = 500 \text{ N-m}$$

\therefore Torque necessary to keep the internal gear stationary

$$= 500 - 100 = 400 \text{ N-m Ans.}$$

Example 13.21. In the epicyclic gear train, as shown in Fig. 13.28, the driving gear A rotating in clockwise direction has 14 teeth and the fixed annular gear C has 100 teeth. The ratio of teeth in gears E and D is 98 : 41. If 1.85 kW is supplied to the gear A rotating at 1200 r.p.m., find : 1. the speed and direction of rotation of gear E, and 2. the fixing torque required at C, assuming 100 per cent efficiency throughout and that all teeth have the same pitch.

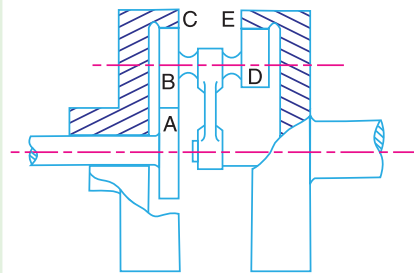

Fig. 13.28

Solution. Given : $T_A = 14$; $T_C = 100$; $T_E / T_D = 98 / 41$; $P_A = 1.85 \text{ kW} = 1850 \text{ W}$; $N_A = 1200 \text{ r.p.m.}$

Let d_A , d_B and d_C be the pitch circle diameters of gears A, B and C respectively. From Fig. 13.28,

$$d_A + 2 d_B = d_C$$



Gears are extensively used in trains for power transmission.





Since teeth of all gears have the same pitch and the number of teeth are proportional to their pitch circle diameters, therefore

$$T_A + 2T_B = T_C \quad \text{or} \quad T_B = \frac{T_C - T_A}{2} = \frac{100 - 14}{2} = 43$$

The table of motions is now drawn as below :

Table 13.23. Table of motions.

Step No.	Conditions of motion	Revolutions of elements				
		Arm	Gear A	Compound gear B-D	Gear C	Gear E
1.	Arm fixed-Gear A rotated through - 1 revolution (i.e. 1 revolution clockwise)	0	- 1	$+\frac{T_A}{T_B}$	$+\frac{T_A}{T_B} \times \frac{T_B}{T_C}$ $= +\frac{T_A}{T_C}$	$+\frac{T_A}{T_B} \times \frac{T_D}{T_E}$
2.	Arm fixed-Gear A rotated through - x revolutions	0	- x	$+x \times \frac{T_A}{T_B}$	$+x \times \frac{T_A}{T_C}$	$+x \times \frac{T_A}{T_B} \times \frac{T_D}{T_E}$
3.	Add - y revolutions to all elements	- y	- y	- y	- y	- y
4.	Total motion	- y	- y - x	$-y + x \times \frac{T_A}{T_B}$	$-y + x \times \frac{T_A}{T_C}$	$-y + x \times \frac{T_A}{T_B} \times \frac{T_D}{T_E}$

Since the annular gear C is fixed, therefore from the fourth row of the table,

$$-y + x \times \frac{T_A}{T_C} = 0 \quad \text{or} \quad -y + x \times \frac{14}{100} = 0$$

$$\therefore -y + 0.14x = 0 \quad \dots(i)$$

Also, the gear A is rotating at 1200 r.p.m., therefore

$$-x - y = 1200 \quad \dots(ii)$$

From equations (i) and (ii), $x = -1052.6$, and $y = -147.4$

1. Speed and direction of rotation of gear E

From the fourth row of the table, speed of gear E,

$$\begin{aligned} N_E &= -y + x \times \frac{T_A}{T_B} \times \frac{T_D}{T_E} = 147.4 - 1052.6 \times \frac{14}{43} \times \frac{41}{98} \\ &= 147.4 - 143.4 = 4 \text{ r.p.m.} \\ &= 4 \text{ r.p.m. (anticlockwise) Ans.} \end{aligned}$$

2. Fixing torque required at C

$$\text{We know that torque on A} = \frac{P_A \times 60}{2\pi N_A} = \frac{1850 \times 60}{2\pi \times 1200} = 14.7 \text{ N-m}$$

Since the efficiency is 100 per cent throughout, therefore the power available at E (P_E) will be equal to power supplied at A (P_A).





468 • Theory of Machines

$$\therefore \text{Torque on } E = \frac{P_A \times 60}{2\pi \times N_E} = \frac{1850 \times 60}{2\pi \times 4} = 4416 \text{ N-m}$$

$$\therefore \text{Fixing torque required at } C = 4416 - 14.7 = 4401.3 \text{ N-m Ans.}$$

Example 13.22. An over drive for a vehicle consists of an epicyclic gear train, as shown in Fig. 13.29, with compound planets B-C. B has 15 teeth and meshes with an annulus A which has 60 teeth. C has 20 teeth and meshes with the sunwheel D which is fixed. The annulus is keyed to the propeller shaft Y which rotates at 740 rad /s. The spider which carries the pins upon which the planets revolve, is driven directly from main gear box by shaft X, this shaft being relatively free to rotate with respect to wheel D. Find the speed of shaft X, when all the teeth have the same module.

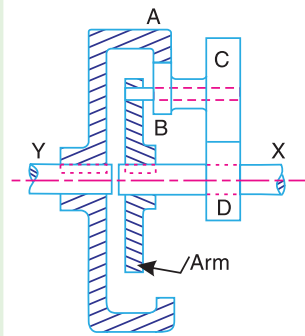

Fig. 13.29

When the engine develops 130 kW, what is the holding torque on the wheel D ? Assume 100 per cent efficiency throughout.

Solution. Given : $T_B = 15$; $T_A = 60$; $T_C = 20$; $\omega_Y = \omega_A = 740 \text{ rad /s}$; $P = 130 \text{ kW} = 130 \times 10^3 \text{ W}$

First of all, let us find the number of teeth on the sunwheel D (T_D). Let d_A , d_B , d_C and d_D be the pitch circle diameters of wheels A, B, C and D respectively. From Fig. 13.29,

$$\frac{d_D}{2} + \frac{d_C}{2} + \frac{d_B}{2} = \frac{d_A}{2} \quad \text{or} \quad d_D + d_C + d_B = d_A$$

Since the module is same for all teeth and the number of teeth are proportional to their pitch circle diameters, therefore

$$T_D + T_C + T_B = T_A \quad \text{or} \quad T_D = T_A - (T_C + T_B) = 60 - (20 + 15) = 25$$

The table of motions is given below :

Table 13.24. Table of motions.

Step No.	Conditions of motion	Revolutions of elements			
		Arm (or shaft X)	Wheel D	Compound wheel C-B	Wheel A (or shaft Y)
1.	Arm fixed-wheel D rotated through + 1 revolution (anticlockwise)	0	+ 1	$-\frac{T_D}{T_C}$	$-\frac{T_D}{T_C} \times \frac{T_B}{T_A}$
2.	Arm fixed-wheel D rotated through + x revolutions	0	+ x	$-x \times \frac{T_D}{T_C}$	$-x \times \frac{T_D}{T_C} \times \frac{T_B}{T_A}$
3.	Add + y revolutions to all elements	+ y	+ y	+ y	+ y
4.	Total motion	+ y	x + y	$y - x \times \frac{T_D}{T_C}$	$y - x \times \frac{T_D}{T_C} \times \frac{T_B}{T_A}$

Since the shaft Y or wheel A rotates at 740 rad/s, therefore

$$y - x \times \frac{T_D}{T_C} \times \frac{T_B}{T_A} = 740 \quad \text{or} \quad y - x \times \frac{25}{20} \times \frac{15}{60} = 740$$

$$y - 0.3125 x = 740$$

...(i)





Also the wheel D is fixed, therefore

$$x + y = 0 \quad \text{or} \quad y = -x \quad \dots(ii)$$

From equations (i) and (ii),

$$x = -563.8 \quad \text{and} \quad y = 563.8$$

Speed of shaft X

Since the shaft X will make the same number of revolutions as the arm, therefore

$$\text{Speed of shaft X, } \omega_x = \text{Speed of arm} = y = 563.8 \text{ rad/s } \mathbf{Ans.}$$

Holding torque on wheel D

We know that torque on $A = P/\omega_A = 130 \times 10^3 / 740 = 175.7 \text{ N-m}$

and Torque on $X = P/\omega_x = 130 \times 10^3 / 563.8 = 230.6 \text{ N-m}$

\therefore Holding torque on wheel D

$$= 230.6 - 175.7 = 54.9 \text{ N-m } \mathbf{Ans.}$$

Example 13.23. Fig. 13.30 shows some details of a compound epicyclic gear drive where I is the driving or input shaft and O is the driven or output shaft which carries two arms A and B rigidly fixed to it. The arms carry planet wheels which mesh with annular wheels P and Q and the sunwheels X and Y . The sun wheel X is a part of Q . Wheels Y and Z are fixed to the shaft I . Z engages with a planet wheel carried on Q and this planet wheel engages the fixed annular wheel R . The numbers of teeth on the wheels are :

$$P = 114, Q = 120, R = 120, X = 36, Y = 24 \text{ and } Z = 30.$$

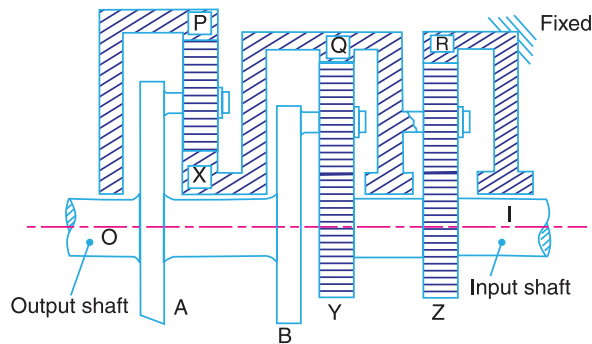

Fig. 13.30.

The driving shaft I makes 1500 r.p.m. clockwise looking from our right and the input at I is 7.5 kW.

1. Find the speed and direction of rotation of the driven shaft O and the wheel P .
2. If the mechanical efficiency of the drive is 80%, find the torque tending to rotate the fixed wheel R .

Solution. Given : $T_P = 114$; $T_Q = 120$; $T_R = 120$; $T_X = 36$; $T_Y = 24$; $T_Z = 30$; $N_1 = 1500$ r.p.m. (clockwise) ; $P = 7.5 \text{ kW} = 7500 \text{ W}$; $\eta = 80\% = 0.8$

First of all, consider the train of wheels Z, R and Q (arm). The revolutions of various wheels are shown in the following table.





470 • Theory of Machines

Table 13.25. Table of motions.

Step No.	Conditions of motion	Revolutions of elements		
		Q (Arm)	Z (also I)	R (Fixed)
1.	Arm fixed-wheel Z rotates through + 1 revolution (anticlockwise)	0	+ 1	$-\frac{T_Z}{T_R}$
2.	Arm fixed-wheel Z rotates through + x revolutions	0	+ x	$-x \times \frac{T_Z}{T_R}$
3.	Add + y revolutions to all elements	+ y	+ y	+ y
4.	Total motion	+ y	x + y	$y - x \times \frac{T_Z}{T_R}$

Since the driving shaft I as well as wheel Z rotates at 1500 r.p.m. clockwise, therefore

$$x + y = -1500 \quad \dots(i)$$

Also, the wheel R is fixed. Therefore

$$y - x \times \frac{T_Z}{T_R} = 0 \quad \text{or} \quad y = x \times \frac{T_Z}{T_R} = x \times \frac{30}{120} = 0.25 x \quad \dots(ii)$$

From equations (i) and (ii),

$$x = -1200, \quad \text{and} \quad y = -300$$

Now consider the train of wheels Y, Q, arm A, wheels P and X. The revolutions of various elements are shown in the following table.

Table 13.26. Table of motions.

Step No.	Conditions of motion	Revolutions of elements			
		Arm A, B and Shaft O	Wheel Y	Compound wheel Q-X	Wheel P
1.	Arm A fixed-wheel Y rotates through + 1 revolution (anticlockwise)	0	+ 1	$-\frac{T_Y}{T_Q}$	$+\frac{T_Y}{T_Q} \times \frac{T_X}{T_P}$
2.	Arm A fixed-wheel Y rotates through + x ₁ revolutions	0	+ x ₁	$-x_1 \times \frac{T_Y}{T_Q}$	$+x_1 \times \frac{T_Y}{T_Q} \times \frac{T_X}{T_P}$
3.	Add + y ₁ revolutions to all elements	+ y ₁	+ y ₁	+ y ₁	+ y ₁
4.	Total motion	+ y ₁	x ₁ + y ₁	$y_1 - x_1 \times \frac{T_Y}{T_Q}$	$y_1 + x_1 \times \frac{T_Y}{T_Q} \times \frac{T_X}{T_P}$

Since the speed of compound wheel Q-X is same as that of Q, therefore

$$y_1 - x_1 \times \frac{T_Y}{T_Q} = y = -300$$

or
$$y_1 - x_1 \times \frac{24}{120} = -300$$





$$\therefore y_1 = 0.2 x_1 - 300 \quad \dots(iii)$$

Also Speed of wheel Y = Speed of wheel Z or shaft I

$$\therefore x_1 + y_1 = x + y = -1500 \quad \dots(iv)$$

$$x_1 + 0.2 x_1 - 300 = -1500 \quad \dots[\text{From equation (iii)}]$$

$$1.2 x_1 = -1500 + 300 = -1200$$

or $x_1 = -1200/1.2 = -1000$

and $y_1 = -1500 - x_1 = -1500 + 1000 = -500$

1. Speed and direction of the driven shaft O and the wheel P

Speed of the driven shaft O ,

$$N_O = y_1 = -500 = 500 \text{ r.p.m. clockwise Ans.}$$

and Speed of the wheel P , $N_P = y_1 + x_1 \times \frac{T_Y}{T_Q} \times \frac{T_X}{T_P} = -500 - 1000 \times \frac{24}{120} \times \frac{36}{144}$

$$= -550 = 550 \text{ r.p.m. clockwise Ans.}$$

2. Torque tending to rotate the fixed wheel R

We know that the torque on shaft I or input torque

$$T_1 = \frac{P \times 60}{2\pi \times N_1} = \frac{7500 \times 60}{2\pi \times 1500} = 47.74 \text{ N-m}$$

and torque on shaft O or output torque,

$$T_2 = \frac{\eta \times P \times 60}{2\pi \times N_O} = \frac{0.8 \times 7500 \times 60}{2\pi \times 500} = 114.58 \text{ N-m}$$

Since the input and output shafts rotate in the same direction (*i.e.* clockwise), therefore input and output torques will be in opposite direction.

\therefore Torque tending to rotate the fixed wheel R

$$= T_2 - T_1 = 114.58 - 47.74 = 66.84 \text{ N-m Ans.}$$

Example 13.24. An epicyclic bevel gear train (known as Humpage's reduction gear) is shown in Fig. 13.31. It consists of a fixed wheel C , the driving shaft X and the driven shaft Y . The compound wheel $B-D$ can revolve on a spindle F which can turn freely about the axis X and Y .

Show that (i) if the ratio of tooth numbers T_B/T_D is greater than T_C/T_E , the wheel E will rotate in the same direction as wheel A , and (ii) if the ratio T_B/T_D is less than T_C/T_E , the direction of E is reversed.

If the numbers of teeth on wheels A, B, C, D and E are 34, 120, 150, 38 and 50 respectively and 7.5 kW is put into the shaft X at 500 r.p.m., what is the output torque of the shaft Y , and what are the forces (tangential to the pitch cones) at the contact points between wheels D and E and between wheels B and C , if the module of all wheels is 3.5 mm?

Solution. Given : $T_A = 34$; $T_B = 120$; $T_C = 150$; $T_D = 38$; $T_E = 50$; $P_X = 7.5 \text{ kW} = 7500 \text{ W}$; $N_X = 500 \text{ r.p.m.}$; $m = 3.5 \text{ mm}$

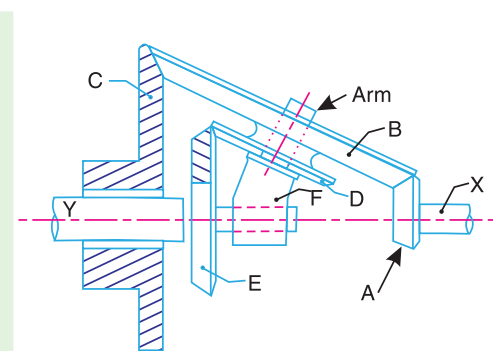

Fig. 13.31





472 • Theory of Machines

The table of motions is given below :

Table 13.27. Table of motions.

Step No.	Conditions of motion	Revolutions of elements				
		Spindle F	Wheel A (or shaft X)	Compound wheel B-D	Wheel C	Wheel E (or shaft Y)
1.	Spindle fixed, wheel A is rotated through + 1 revolution	0	+ 1	$+\frac{T_A}{T_B}$	$-\frac{T_A}{T_B} \times \frac{T_B}{T_C}$ $= -\frac{T_A}{T_C}$	$-\frac{T_A}{T_B} \times \frac{T_D}{T_E}$
2.	Spindle fixed, wheel A is rotated through + x revolutions	0	+ x	$+x \times \frac{T_A}{T_B}$	$-x \times \frac{T_A}{T_C}$	$-x \times \frac{T_A}{T_B} \times \frac{T_D}{T_E}$
3.	Add + y revolutions to all elements	+ y	+ y	+ y	+ y	+ y
4.	Total motion	+ y	x + y	$y + x \times \frac{T_A}{T_B}$	$y - x \times \frac{T_A}{T_C}$	$y - x \times \frac{T_A}{T_B} \times \frac{T_D}{T_E}$

Let us assume that the driving shaft X rotates through 1 revolution anticlockwise, therefore the wheel A will also rotate through 1 revolution anticlockwise.

$$\therefore x + y = +1 \quad \text{or} \quad y = 1 - x \quad \dots(i)$$

We also know that the wheel C is fixed, therefore

$$y - x \times \frac{T_A}{T_C} = 0 \quad \text{or} \quad (1 - x) - x \times \frac{T_A}{T_C} = 0 \quad \dots[\text{From equation (i)}]$$

$$1 - x \left(1 + \frac{T_A}{T_C} \right) = 0 \quad \text{or} \quad x \left(\frac{T_C + T_A}{T_C} \right) = 1$$

and
$$x = \frac{T_C}{T_C + T_A} \quad \dots(ii)$$

From equation (i),

$$y = 1 - x = 1 - \frac{T_C}{T_C + T_A} = \frac{T_A}{T_C + T_A} \quad \dots(iii)$$

We know that speed of wheel E,

$$\begin{aligned} N_E &= y - x \times \frac{T_A}{T_B} \times \frac{T_D}{T_E} = \frac{T_A}{T_C + T_A} - \frac{T_C}{T_C + T_A} \times \frac{T_A}{T_B} \times \frac{T_D}{T_E} \\ &= \frac{T_A}{T_C + T_A} \left(1 - \frac{T_C}{T_B} \times \frac{T_D}{T_E} \right) \quad \dots(iv) \end{aligned}$$

and the speed of wheel A,

$$N_A = x + y = +1 \text{ revolution}$$

(i) If $\frac{T_B}{T_D} > \frac{T_C}{T_E}$ or $T_B \times T_E > T_C \times T_D$, then the equation (iv) will be positive. Therefore the

wheel E will rotate in the same direction as wheel A. **Ans.**





(ii) If $\frac{T_B}{T_D} < \frac{T_C}{T_E}$ or $T_B \times T_E < T_C \times T_D$, then the equation (iv) will be negative. Therefore the wheel E will rotate in the opposite direction as wheel A . **Ans.**

Output torque of shaft Y

We know that the speed of the driving shaft X (or wheel A) or input speed is 500 r.p.m., therefore from the fourth row of the table,

$$x + y = 500 \quad \text{or} \quad y = 500 - x \quad \dots(v)$$

Since the wheel C is fixed, therefore

$$y - x \times \frac{T_A}{T_C} = 0 \quad \text{or} \quad (500 - x) - x \times \frac{34}{150} = 0 \quad \dots[\text{From equation (v)}]$$

$$\therefore 500 - x - 0.227x = 0 \quad \text{or} \quad x = 500/1.227 = 407.5 \text{ r.p.m.}$$

and $y = 500 - x = 500 - 407.5 = 92.5 \text{ r.p.m.}$

Since the speed of the driven or output shaft Y (i.e. N_Y) is equal to the speed of wheel E (i.e. N_E), therefore

$$\begin{aligned} N_Y = N_E &= y - x \times \frac{T_A}{T_B} \times \frac{T_D}{T_E} = 92.5 - 407.5 \times \frac{34}{120} \times \frac{38}{50} \\ &= 92.5 - 87.75 = 4.75 \text{ r.p.m.} \end{aligned}$$

Assuming 100 per cent efficiency of the gear train, input power P_X is equal to output power (P_Y), i.e.

$$P_Y = P_X = 7.5 \text{ kW} = 7500 \text{ W}$$

\therefore Output torque of shaft Y ,

$$= \frac{P_Y \times 60}{2\pi N_Y} = \frac{7500 \times 60}{2\pi \times 4.75} = 15\,076 \text{ N-m} = 15.076 \text{ kN-m} \quad \mathbf{Ans.}$$

Tangential force between wheels D and E

We know that the pitch circle radius of wheel E ,

$$r_E = \frac{m \times T_E}{2} = \frac{3.5 \times 50}{2} = 87.5 \text{ mm} = 0.0875 \text{ m}$$

\therefore Tangential force between wheels D and E ,

$$= \frac{\text{Torque on wheel } E}{\text{Pitch circle radius of wheel } E} = \frac{15\,076}{0.0875} = 172.3 \text{ kN} \quad \mathbf{Ans.}$$

...(\therefore Torque on wheel E = Torque on shaft Y)

Tangential force between wheels B and C

We know that the input torque on shaft X or on wheel A

$$= \frac{P_X \times 60}{2\pi N_X} = \frac{7500 \times 60}{2\pi \times 500} = 143 \text{ N-m}$$

\therefore Fixing torque on the fixed wheel C

$$\begin{aligned} &= \text{Torque on wheel } E - \text{Torque on wheel } A \\ &= 15\,076 - 143 = 14\,933 \text{ N-m} = 14.933 \text{ kN-m} \end{aligned}$$





474 • Theory of Machines

Pitch circle radius of wheel C ,

$$r_c = \frac{m \times T_c}{2} = \frac{3.5 \times 150}{2} = 262.5 \text{ mm} = 0.2625 \text{ m}$$

Tangential force between wheels B and C

$$= \frac{\text{Fixing torque on wheel } C}{r_c} = \frac{14.933}{0.2625} = 57 \text{ kN Ans.}$$

EXERCISES

1. A compound train consists of six gears. The number of teeth on the gears are as follows :

Gear	:	A	B	C	D	E	F
No. of teeth	:	60	40	50	25	30	24

The gears B and C are on one shaft while the gears D and E are on another shaft. The gear A drives gear B , gear C drives gear D and gear E drives gear F . If the gear A transmits 1.5 kW at 100 r.p.m. and the gear train has an efficiency of 80 per cent, find the torque on gear F . [Ans. 30.55 N-m]

2. Two parallel shafts are to be connected by spur gearing. The approximate distance between the shafts is 600 mm. If one shaft runs at 120 r.p.m. and the other at 360 r.p.m., find the number of teeth on each wheel, if the module is 8 mm. Also determine the exact distance apart of the shafts. [Ans. 114, 38 ; 608 mm]

3. In a reverted gear train, as shown in Fig. 13.32, two shafts A and B are in the same straight line and are geared together through an intermediate parallel shaft C . The gears connecting the shafts A and C have a module of 2 mm and those connecting the shafts C and B have a module of 4.5 mm. The speed of shaft A is to be about but greater than 12 times the speed of shaft B , and the ratio at each reduction is same. Find suitable number of teeth for gears. The number of teeth of each gear is to be a minimum but not less than 16. Also find the exact velocity ratio and the distance of shaft C from A and B . [Ans. 36, 126, 16, 56 ; 12.25 ; 162 mm]

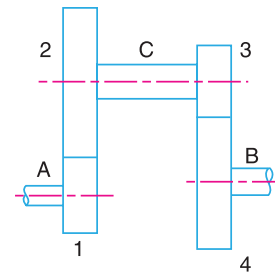

Fig. 13.32

4. In an epicyclic gear train, as shown in Fig. 13.33, the number of teeth on wheels A , B and C are 48, 24 and 50 respectively. If the arm rotates at 400 r.p.m., clockwise, find : 1. Speed of wheel C when A is fixed, and 2. Speed of wheel A when C is fixed. [Ans. 16 r.p.m. (clockwise) ; 16.67 (anticlockwise)]

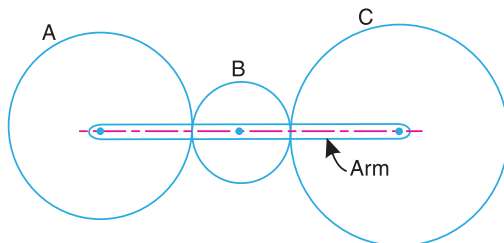

Fig. 13.33

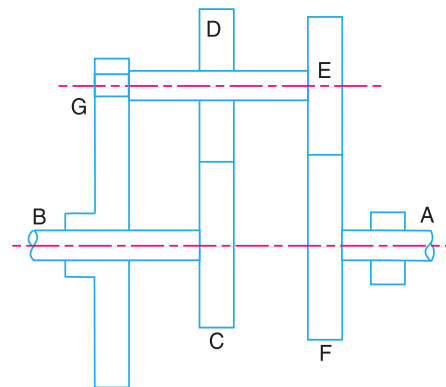

Fig. 13.34





5. In an epicyclic gear train, as shown in Fig. 13.34, the wheel C is keyed to the shaft B and wheel F is keyed to shaft A . The wheels D and E rotate together on a pin fixed to the arm G . The number of teeth on wheels C, D, E and F are 35, 65, 32 and 68 respectively. If the shaft A rotates at 60 r.p.m. and the shaft B rotates at 28 r.p.m. in the opposite direction, find the speed and direction of rotation of arm G . [Ans. 90 r.p.m., in the same direction as shaft A]
6. An epicyclic gear train, as shown in Fig. 13.35, is composed of a fixed annular wheel A having 150 teeth. The wheel A is meshing with wheel B which drives wheel D through an idle wheel C, D being concentric with A . The wheels B and C are carried on an arm which revolves clockwise at 100 r.p.m. about the axis of A and D . If the wheels B and D have 25 teeth and 40 teeth respectively, find the number of teeth on C and the speed and sense of rotation of C . [Ans. 30 ; 600 r.p.m. clockwise]

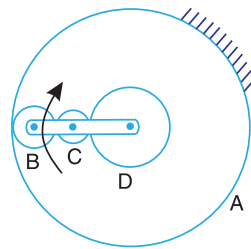

Fig. 13.35

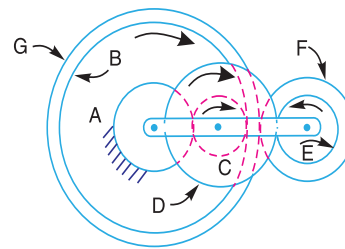

Fig. 13.36

7. Fig. 13.36, shows an epicyclic gear train with the following details :
 A has 40 teeth external (fixed gear) ; B has 80 teeth internal ; $C - D$ is a compound wheel having 20 and 50 teeth (external) respectively, $E - F$ is a compound wheel having 20 and 40 teeth (external) respectively, and G has 90 teeth (external).
 The arm runs at 100 r.p.m. in clockwise direction. Determine the speeds for gears C, E , and B .
 [Ans. 300 r.p.m. clockwise ; 400 r.p.m. anticlockwise ; 150 r.p.m. clockwise]
8. An epicyclic gear train, as shown in Fig. 13.37, has a sun wheel S of 30 teeth and two planet wheels $P - P$ of 50 teeth. The planet wheels mesh with the internal teeth of a fixed annulus A . The driving shaft carrying the sunwheel, transmits 4 kW at 300 r.p.m. The driven shaft is connected to an arm which carries the planet wheels. Determine the speed of the driven shaft and the torque transmitted, if the overall efficiency is 95%.
 [Ans. 56.3 r.p.m. ; 644.5 N-m]

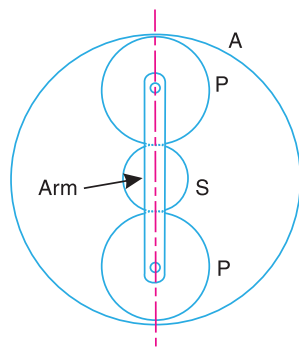

Fig. 13.37

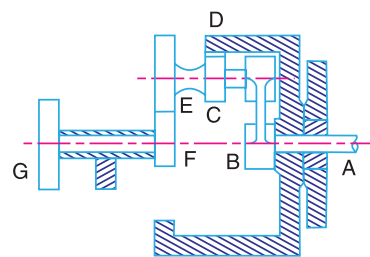

Fig. 13.38

9. An epicyclic reduction gear, as shown in Fig. 13.38, has a shaft A fixed to arm B . The arm B has a pin fixed to its outer end and two gears C and E which are rigidly fixed, revolve on this pin. Gear C meshes with annular wheel D and gear E with pinion F . G is the driver pulley and D is kept stationary. The number of teeth are : $D = 80$; $C = 10$; $E = 24$ and $F = 18$.
 If the pulley G runs at 200 r.p.m. ; find the speed of shaft A .

[Ans. 17.14 r.p.m. in the same direction as that of G]





476 • Theory of Machines

10. A reverted epicyclic gear train for a hoist block is shown in Fig. 13.39. The arm E is keyed to the same shaft as the load drum and the wheel A is keyed to a second shaft which carries a chain wheel, the chain being operated by hand. The two shafts have common axis but can rotate independently. The wheels B and C are compound and rotate together on a pin carried at the end of arm E . The wheel D has internal teeth and is fixed to the outer casing of the block so that it does not rotate.

The wheels A and B have 16 and 36 teeth respectively with a module of 3 mm. The wheels C and D have a module of 4 mm. Find : 1. the number of teeth on wheels C and D when the speed of A is ten times the speed of arm E , both rotating in the same sense, and 2. the speed of wheel D when the wheel A is fixed and the arm E rotates at 450 r.p.m. anticlockwise.

[Ans. $T_C = 13$; $T_D = 52$; 500 r.p.m. anticlockwise]

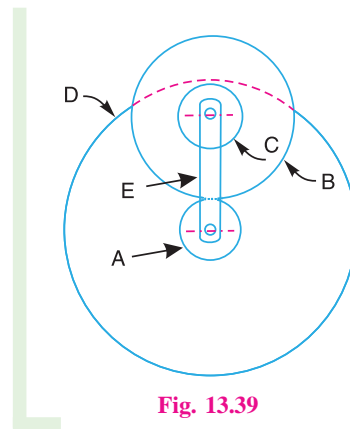

Fig. 13.39

11. A compound epicyclic gear is shown diagrammatically in Fig. 13.40. The gears A , D and E are free to rotate on the axis P . The compound gear B and C rotate together on the axis Q at the end of arm F . All the gears have equal pitch. The number of external teeth on the gears A , B and C are 18, 45 and 21 respectively. The gears D and E are annular gears. The gear A rotates at 100 r.p.m. in the anticlockwise direction and the gear D rotates at 450 r.p.m. clockwise. Find the speed and direction of the arm and the gear E .

[Ans. 400 r.p.m. clockwise ; 483.3 r.p.m. clockwise]

12. In an epicyclic gear train of the 'sun and planet type' as shown in Fig. 13.41, the pitch circle diameter of the internally toothed ring D is to be 216 mm and the module 4 mm. When the ring D is stationary, the spider A , which carries three planet wheels C of equal size, is to make one revolution in the same sense as the sun wheel B for every five revolutions of the driving spindle carrying the sunwheel B . Determine suitable number of teeth for all the wheels and the exact diameter of pitch circle of the ring.

[Ans. $T_B = 14$, $T_C = 21$, $T_D = 56$; 224 mm]

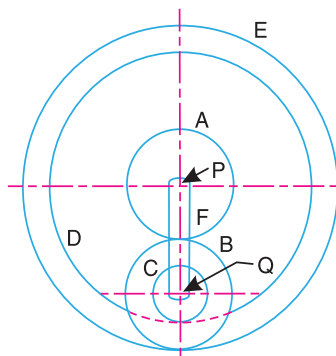

Fig. 13.40

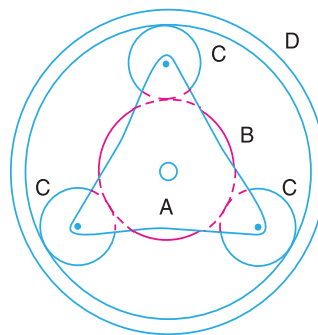

Fig. 13.41

13. An epicyclic train is shown in Fig. 13.42. Internal gear A is keyed to the driving shaft and has 30 teeth. Compound wheel C and D of 20 and 22 teeth respectively are free to rotate on the pin fixed to the arm P which is rigidly connected to the driven shaft. Internal gear B which has 32 teeth is fixed. If the driving shaft runs at 60 r.p.m. clockwise, determine the speed of the driven shaft. What is the direction of rotation of driven shaft with reference to driving shaft?

[Ans. 1980 r.p.m. clockwise]



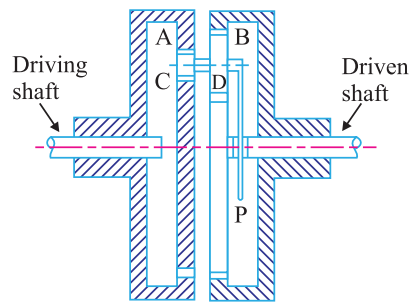

Fig. 13.42

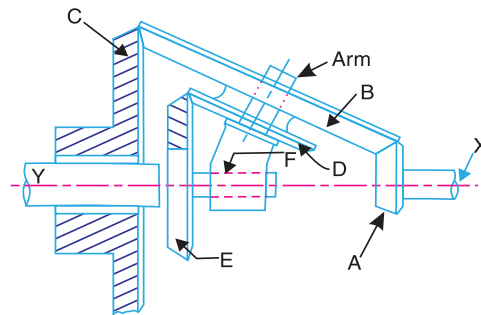

Fig. 13.43

14. A shaft Y is driven by a co-axial shaft X by means of an epicyclic gear train, as shown in Fig. 13.43. The wheel A is keyed to X and E to Y . The wheels B and D are compound and carried on an arm F which can turn freely on the common axes of X and Y . The wheel C is fixed. If the numbers of teeth on A, B, C, D and E are respectively 20, 64, 80, 30 and 50 and the shaft X makes 600 r.p.m., determine the speed in r.p.m. and sense of rotation of the shaft Y .

[Ans. 30 r.p.m. in the same sense as shaft X]

15. An epicyclic bevel gear train, as shown in Fig. 13.44, has fixed gear B meshing with pinion C . The gear E on the driven shaft meshes with the pinion D . The pinions C and D are keyed to a shaft, which revolves in bearings on the arm A . The arm A is keyed to the driving shaft. The number of teeth are : $T_B = 75, T_C = 20, T_D = 18,$ and $T_E = 70$. Find the speed of the driven shaft, if 1. the driving shaft makes 1000 r.p.m., and 2. the gear B turns in the same sense as the driving shaft at 400 r.p.m., the driving shaft still making 1000 r.p.m.

[Ans. 421.4 r.p.m. in the same direction as driving shaft]

16. The epicyclic gear train is shown in Fig. 13.45. The wheel D is held stationary by the shaft A and the arm B is rotated at 200 r.p.m. The wheels E (20 teeth) and F (40 teeth) are fixed together and rotate freely on the pin carried by the arm. The wheel G (30 teeth) is rigidly attached to the shaft C . Find the speed of shaft C stating the direction of rotation to that of B .

If the gearing transmits 7.5 kW, what will be the torque required to hold the shaft A stationary, neglecting all friction losses?

[Ans. 466.7 r.p.m. in opposite direction of B ; 511.5 N-m in opposite direction of B]

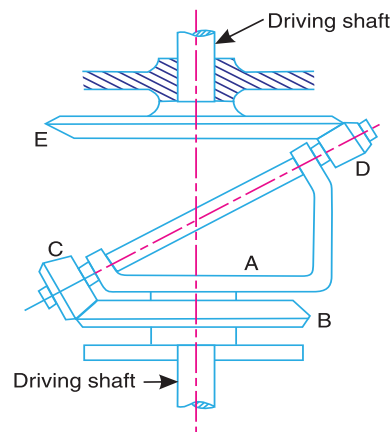

Fig. 13.44

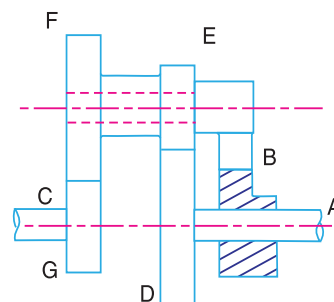

Fig. 13.45

17. An epicyclic gear train, as shown in Fig. 13.46, consists of two sunwheels A and D with 28 and 24 teeth respectively, engaged with a compound planet wheels B and C with 22 and 26 teeth. The sunwheel





478 • Theory of Machines

D is keyed to the driven shaft and the sunwheel A is a fixed wheel co-axial with the driven shaft. The planet wheels are carried on an arm E from the driving shaft which is co-axial with the driven shaft. Find the velocity ratio of gear train. If 0.75 kW is transmitted and input speed being 100 r.p.m., determine the torque required to hold the sunwheel A . [Ans. 2.64 ; 260.6 N-m]

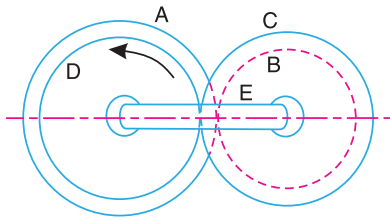

Fig. 13.46

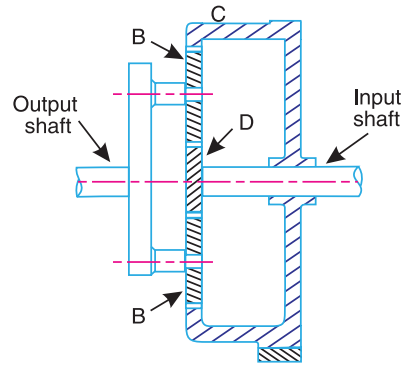

Fig. 13.47

18. In the epicyclic reduction gear, as shown in Fig. 13.47, the sunwheel D has 20 teeth and is keyed to the input shaft. Two planet wheels B , each having 50 teeth, gear with wheel D and are carried by an arm A fixed to the output shaft. The wheels B also mesh with an internal gear C which is fixed. The input shaft rotates at 2100 r.p.m. Determine the speed of the output shaft and the torque required to fix C when the gears are transmitting 30 kW.

[Ans. 300 r.p.m. in the same sense as the input shaft ; 818.8 N-m]

19. An epicyclic gear train for an electric motor is shown in Fig. 13.48. The wheel S has 15 teeth and is fixed to the motor shaft rotating at 1450 r.p.m. The planet P has 45 teeth, gears with fixed annulus A and rotates on a spindle carried by an arm which is fixed to the output shaft. The planet P also gears with the sun wheel S . Find the speed of the output shaft. If the motor is transmitting 1.5 kW, find the torque required to fix the annulus A .

[Ans. 181.3 r.p.m. ; 69.14 N-m]

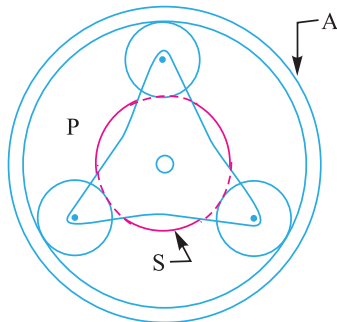

Fig. 13.48

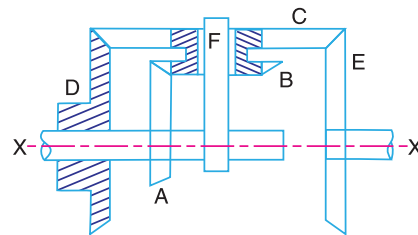

Fig. 13.49

20. An epicyclic gear consists of bevel wheels as shown in Fig. 13.49. The driving pinion A has 20 teeth and meshes with the wheel B which has 25 teeth. The wheels B and C are fixed together and turn freely on the shaft F . The shaft F can rotate freely about the main axis XX . The wheel C has 50 teeth and meshes with wheels D and E , each of which has 60 teeth. Find the speed and direction of E when A rotates at 200 r.p.m., if

1. D is fixed, and 2. D rotates at 100 r.p.m., in the same direction as A .

In both the cases, find the ratio of the torques transmitted by the shafts of the wheels A and E , the friction being neglected.

[Ans. 800 r.p.m. in the opposite direction of A ; 300 r.p.m. in the opposite direction of A ; 4 ; 1.5]





DO YOU KNOW ?

1. What do you understand by 'gear train'? Discuss the various types of gear trains.
2. Explain briefly the differences between simple, compound, and epicyclic gear trains. What are the special advantages of epicyclic gear trains ?
3. Explain the procedure adopted for designing the spur wheels.
4. How the velocity ratio of epicyclic gear train is obtained by tabular method?
5. Explain with a neat sketch the 'sun and planet wheel'.
6. What are the various types of the torques in an epicyclic gear train ?

OBJECTIVE TYPE QUESTIONS

1. In a simple gear train, if the number of idle gears is odd, then the motion of driven gear will
 - (a) be same as that of driving gear
 - (b) be opposite as that of driving gear
 - (c) depend upon the number of teeth on the driving gear
 - (d) none of the above
2. The train value of a gear train is
 - (a) equal to velocity ratio of a gear train
 - (b) reciprocal of velocity ratio of a gear train
 - (c) always greater than unity
 - (d) always less than unity
3. When the axes of first and last gear are co-axial, then gear train is known as
 - (a) simple gear train
 - (b) compound gear train
 - (c) reverted gear train
 - (d) epicyclic gear train
4. In a clock mechanism, the gear train used to connect minute hand to hour hand, is
 - (a) epicyclic gear train
 - (b) reverted gear train
 - (c) compound gear train
 - (d) simple gear train
5. In a gear train, when the axes of the shafts, over which the gears are mounted, move relative to a fixed axis, is called
 - (a) simple gear train
 - (b) compound gear train
 - (c) reverted gear train
 - (d) epicyclic gear train
6. A differential gear in an automobile is a
 - (a) simple gear train
 - (b) epicyclic gear train
 - (c) compound gear train
 - (d) none of these
7. A differential gear in automobiles is used to
 - (a) reduce speed
 - (b) assist in changing speed
 - (c) provide jerk-free movement of vehicle
 - (d) help in turning

ANSWERS

- | | | | | |
|--------|--------|--------|--------|--------|
| 1. (a) | 2. (b) | 3. (c) | 4. (b) | 5. (d) |
| 6. (b) | 7. (d) | | | |