

UNIT – V

INVERTERS

Introduction to Inverters

The word 'inverter' in the context of power-electronics denotes a class of power conversion (or power conditioning) circuits that operates from a dc voltage source or a dc current source and converts it into ac voltage or current. The inverter does reverse of what ac-to-dc converter does (refer to ac to dc converters). Even though input to an inverter circuit is a dc source, it is not uncommon to have this dc derived from an ac source such as utility ac supply. Thus, for example, the primary source of input power may be utility ac voltage supply that is converted to dc by an ac to dc converter and then 'inverted' back to ac using an inverter. Here, the final ac output may be of a different frequency and magnitude than the input ac of the utility supply

A single phase Half Bridge DC-AC inverter is shown in Figure below

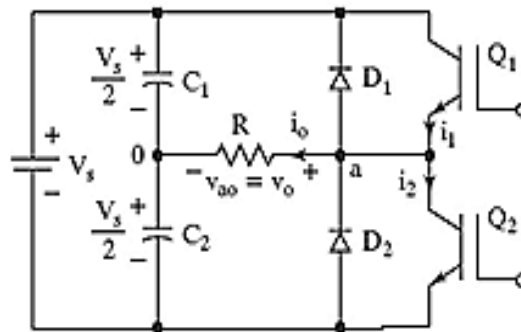

Figure: 5.1 Single phase Half Bridge DC-AC inverter with R load

The analysis of the DC-AC inverters is done taking into accounts the following assumptions and conventions.

- 1) The current entering node a is considered to be positive.
- 2) The switches S1 and S2 are unidirectional, i.e. they conduct current in one direction.
- 3) The current through S1 is denoted as i_1 and the current through S2 is i_2 .

The switching sequence is so design is shown in Figure below. Here, switch S1 is on for the time duration $0 \leq t \leq T_1$ and the switch S2 is on for the time duration $T_1 \leq t \leq T_2$. When switch S1 is turned on, the instantaneous voltage across the load is $v_o = V_{in}/2$

When the switch S2 is only turned on, the voltage across the load is

$$v_o = -V_{in}/2.$$

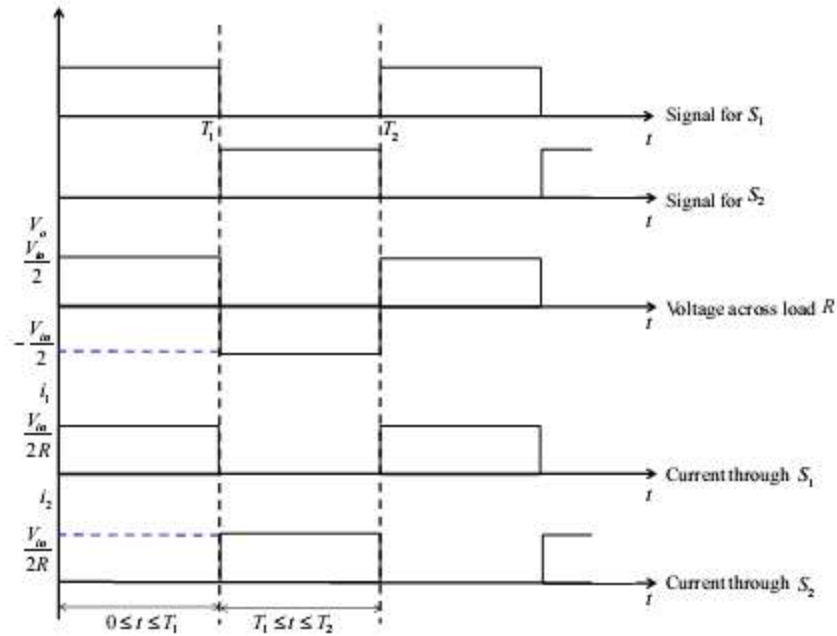

Figure: 5.2 Single phase Half Bridge DC-AC inverter output waveforms

The r.m.s value of output voltage v_o is given by,

$$V_{o,rms} = \left(\frac{1}{T_1} \int_0^{T_1} \frac{V_m^2}{4} dt \right) = \frac{V_m}{2}$$

The instantaneous output voltage v_o is rectangular in shape. The instantaneous value of v_o can be expressed in Fourier series as,

$$v_o = \frac{a_0}{2} + \sum_{n=1}^{\infty} a_n \cos(n\omega t) + b_n \sin(n\omega t)$$

Due to the quarter wave symmetry along the time axis, the values of a_0 and a_n are zero. The value of b_n is given by,

$$b_n = \frac{1}{\pi} \left[\int_{-\pi/2}^0 \frac{-V_m}{2} d(\omega t) + \int_0^{\pi/2} \frac{V_m}{2} d(\omega t) \right] = \frac{2V_m}{n\pi}$$

Substituting the value of b_n from above equation, we get

$$v_o = \sum_{n=1,3,5,\dots}^{\infty} \frac{2V_{in}}{n\pi} \sin(n\omega t)$$

The current through the resistor (i_L) is given by,

$$i_L = \sum_{n=1,3,5,\dots}^{\infty} \frac{1}{R} \frac{2V_{in}}{n\pi} \sin(n\omega t)$$

Half Bridge DC-AC Inverter with L Load and R-L Load

The DC-AC converter with inductive load is shown in Figure below. For an inductive load, the load current cannot change immediately with the output voltage.

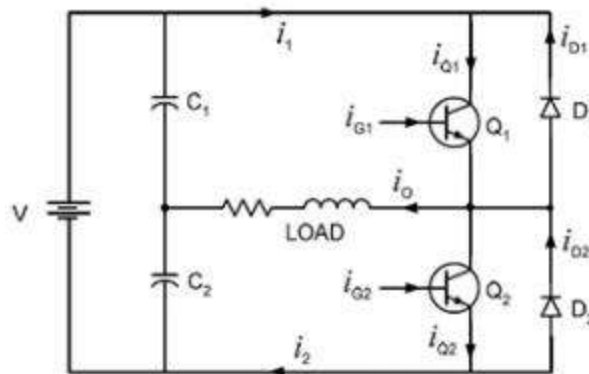

Figure: 5.3 Single phase Half Bridge DC-AC inverter with RL load

The working of the DC-AC inverter with inductive load is as follows:

Case 1: In the time interval $0 \leq t \leq T_1$ the switch S1 is on and the current flows through the inductor from points a to b. When the switch S1 is turned off (case 1) at $t = T_1$, the load current would continue to flow through the capacitor C2 and diode D2 until the current falls to zero, as shown in Figure below.

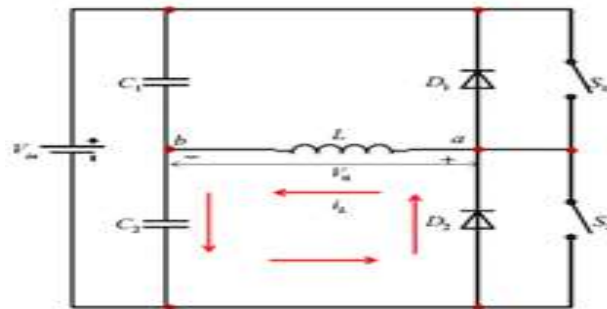

Figure: 5.4 Single phase Half Bridge DC-AC inverter with L load

Case 2: Similarly, when S2 is turned off at $t = T1$, the load current flows through the diode D1 and capacitor C1 until the current falls to zero, as shown in Figure below.

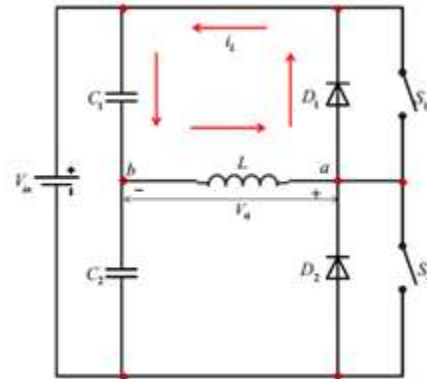

Figure: 5.5 Single phase Half Bridge DC-AC inverter with L load

When the diodes D1 and D2 conduct, energy is feedback to the dc source and these diodes are known as feedback diodes. These diodes are also known as freewheeling diodes. The current for purely inductive load is given by,

$$i_L = \sum_{n=1,3,5,\dots}^{\infty} \frac{1}{\omega n L} \frac{2V_{in}}{n\pi} \sin\left(n\omega t - \frac{\pi}{2}\right)$$

Similarly, for the R – L load. The instantaneous load current is obtained as,

$$i_L = \sum_{n=1,3,5,\dots}^{\infty} \frac{2V_{in}}{n\pi \sqrt{R^2 + (n\omega L)^2}} \sin(n\omega t - \theta_n)$$

Where,

$$\theta_n = \tan^{-1}\left(\frac{n\omega L}{R}\right)$$

Operation of single phase full bridge inverter

A single phase bridge DC-AC inverter is shown in Figure below. The analysis of the single phase DC-AC inverters is done taking into account following assumptions and conventions.

- 1) The current entering node a in Figure 8 is considered to be positive.
- 2) The switches S1, S2, S3 and S4 are unidirectional, i.e. they conduct current in one direction.

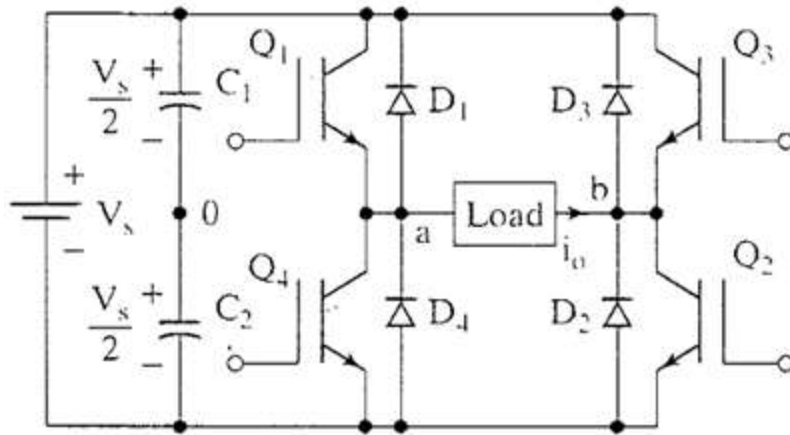

Figure: 5.6 Single phase Full Bridge DC-AC inverter with R load

When the switches S1 and S2 are turned on simultaneously for a duration $0 \leq t \leq T_1$, the the input voltage V_{in} appears across the load and the current flows from point a to b.

$Q_1 - Q_2$ ON, $Q_3 - Q_4$ OFF $\implies v_o = V_s$

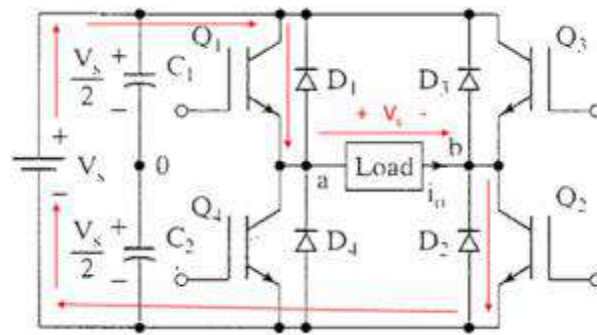

Figure: 5.7 Single phase Full Bridge DC-AC inverter with R load

If the switches S3 and S4 turned on duration $T_1 \leq t \leq T_2$, the voltage across the load the load is reversed and the current through the load flows from point b to a.

$Q_1 - Q_2$ OFF, $Q_3 - Q_4$ ON $\implies v_o = -V_s$

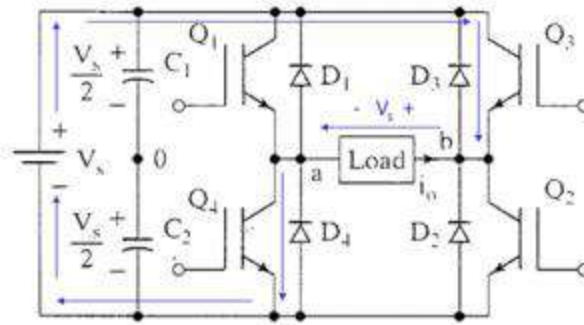

Figure: 5.8 Single phase Full Bridge DC-AC inverter with R load current directions

The voltage and current waveforms across the resistive load are shown in Figure below

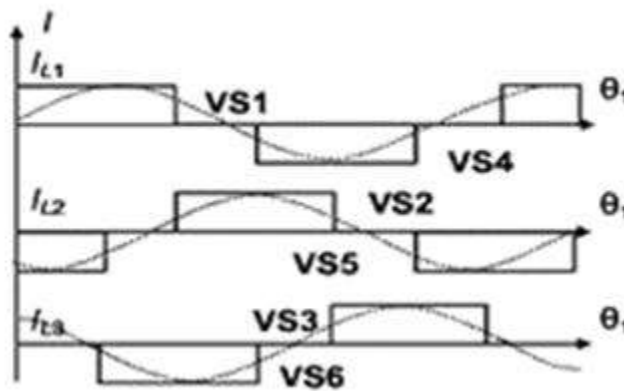

Figure: 5.9 Single phase Full Bridge DC-AC inverter waveforms

Single Phase Full Bridge Inverter for R-L load:

A single-phase square wave type voltage source inverter produces square shaped output voltage for a single-phase load. Such inverters have very simple control logic and the power switches need to operate at much lower frequencies compared to switches in some other types of inverters. The first generation inverters, using thyristor switches, were almost invariably square wave inverters because thyristor switches could be switched on and off only a few hundred times in a second. In contrast, the present day switches like IGBTs are much faster and used at switching frequencies of several kilohertz. Single-phase inverters mostly use half bridge or full bridge topologies. Power circuits of these topologies are shown in in Figure below.

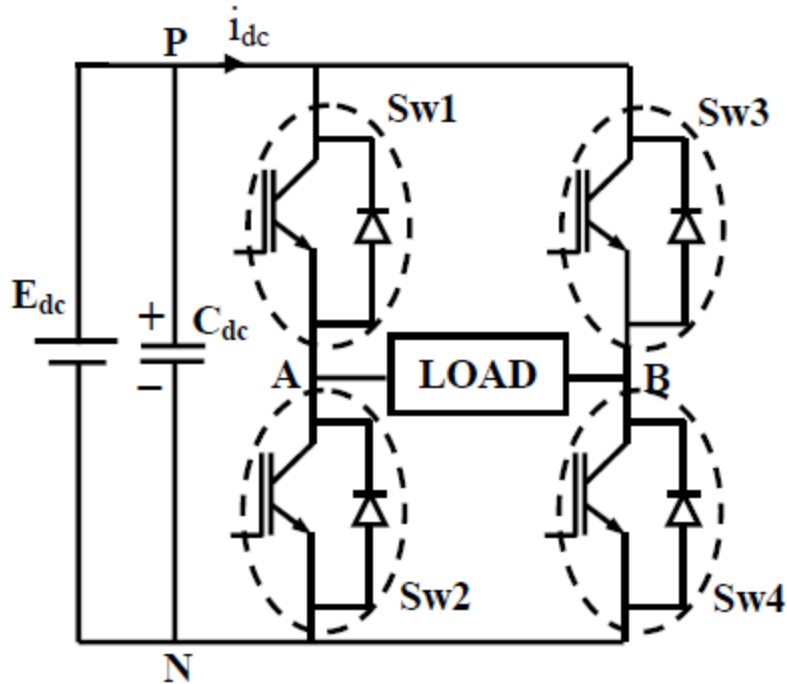

Figure: 5.10 Single phase Full Bridge DC-AC inverter with L load

The above topology is analyzed under the assumption of ideal circuit conditions. Accordingly, it is assumed that the input dc voltage (E_{dc}) is constant and the switches are lossless. In full bridge topology has two such legs. Each leg of the inverter consists of two series connected electronic switches shown within dotted lines in the figures. Each of these switches consists of an IGBT type controlled switch across which an uncontrolled diode is put in anti-parallel manner. These switches are capable of conducting bi-directional current but they need to block only one polarity of voltage. The junction point of the switches in each leg of the inverter serves as one output point for the load.

Series inverter:

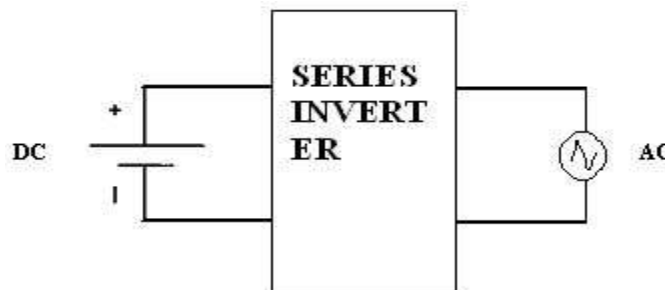

Figure: 5.11 Block diagram of series inverter

In **series inverter**, the commutating elements L and C are connected in series with the load. This constitutes a series RLC resonant circuit. The Two **SCRs** are used to produce the halves (positive and negative half cycle) in the output.

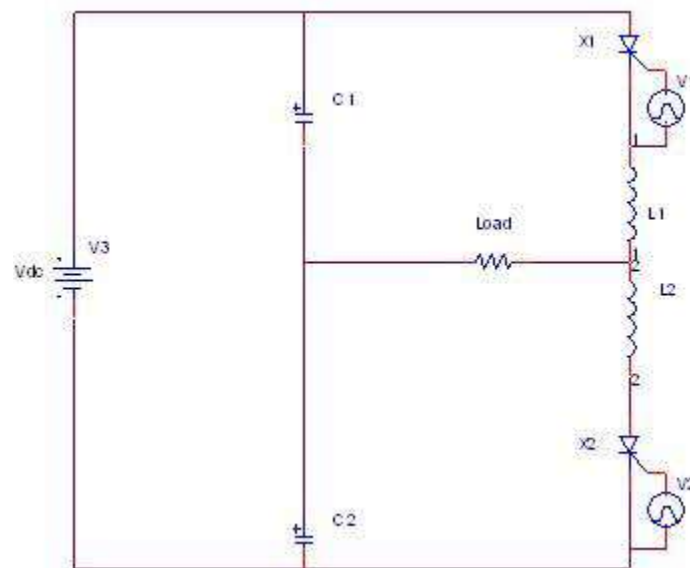

Figure: 5.12 Circuit diagram of series inverter

In the first half of the output currents when **SCR** T1 is triggered it will allow the current to flow through L1, and load, and C2 thus charging. The capacitor C1 which is already charged at these instant discharges through **SCR1**, L1 and the Load. Hence 50% of the current is drawn from the input source and 50% from the capacitor. Similarly in the second half of the output current C1 will be charged and C2 will discharge through the load, L2 and **SCR2**, Again 50% of the load current is obtained from the DC input source and rest from the capacitor. The **SCRs** T1 and T2 are alternatively fired to get AC voltage and current.

Operation of parallel inverter

The **single phase parallel inverter circuit** consists of two **SCRs** T1 and T2, an inductor L, an output transformer and a commutating capacitor C. The output voltage and current are V_o and I_o respectively. The function of L is to make the source current constant. During the working of this

inverter, capacitor C comes in **parallel** with the load via the transformer. So it is called a **parallel inverter**.

The operation of this inverter can be explained in the following modes.

Mode I

In this mode, **SCR T1** is conducting and a current flow in the upper half of primary winding. **SCR T2** is OFF. As a result an emf V_s is induced across upper as well as lower half of the primary winding.

In other words total voltage across primary winding is $2V_s$. Now the capacitor C charges to a voltage of $2V_s$ with upper plate as positive.

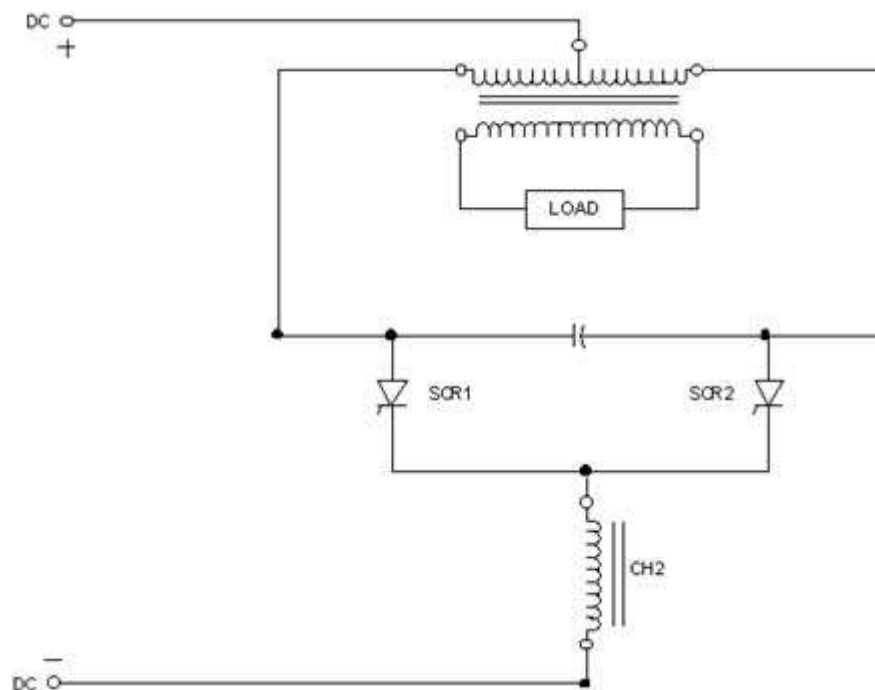

Figure: 5.13 Circuit diagram of parallel inverter

Mode II

At time t_0 , T2 is turned ON by applying a trigger pulse to its gate. At this time $t=0$, capacitor voltage $2V_s$ appears as a reverse bias across T1, it is therefore turned OFF. A current I_o begins to flow through T2 and lower half of primary winding. Now the capacitor has charged (upper plate as negative) from $+2V_s$ to $-2V_s$ at time $t=t_1$. Load voltage also changes from V_s at $t=0$ to $-V_s$ at $t=t_1$.

Mode III

When capacitor has charged to $-V_s$, T1 may be turned ON at any time. When T1 is triggered, capacitor voltage $2V_s$ applies a reverse bias across T2, it is therefore turned OFF. After T2 is OFF, capacitor starts discharging, and charged to the opposite direction, the upper plate as positive.

Paralleled Commutated Inverter

Fig 1: is a schematic of the classical **parallel** commutated square wave inverter bridge. It is being included here for illustrative purposes since most other circuits utilize this circuit or a variation thereof. The waveform generated and supplied to the load is basically a square wave having a peak to peak amplitude of twice the DC supply voltage and a period that is determined by the rate at which **SCRs** 1 through 4 are gated on. The **SCRs** are turned on in pairs by simultaneously applying signals to the gate terminals of **SCRs** 1 and 4 or **SCRs** 2 and 3. If **SCRs** 1 and 4 happen to be the first two switched on a current will flow from the positive terminal of the source through negative terminal of the source. This will establish a left to right, plus to minus voltage relationship on the load.

Simultaneously, the left terminal of capacitor C1 will be charged positively with respect to the right negative terminal. The steady-state load current through the various components is determined nearly completely by the impedance of the load. Chokes 1 and 2 and **SCRs** 1 and 4 present very low steady-state drops and therefore nearly all the source voltage appears across the load. Conduction of **SCRs** 1 and 4 will continue to the end of the half cycle, at which point the gates are removed from **SCRs** 1 and 4 remain in conduction along with **SCRs** 2 and 3 that have now been turned on. If it were not for chokes 1 and 2, the action of turning on the second set of **SCRs** would place very low impedance and therefore momentarily prevent the source from being short-circuited.

Capacitor C1 now discharges with a current which flows into the cathode of **SCR 1** through **SCR 2** in a forward direction back to the negative terminal of the capacitor. This direction of current flow causes **SCR 1** to become non-conductive provided that the reverse current through the **SCR** is of sufficient duration for the **SCR** to again become blocking. C1 simultaneously discharges through **SCR 3** in a forward direction and through **SCR 4** in a reverse direction. This will cause **SCR 4** to become non-conductive just the same **SCR 1**. This entire sequence is referred to as commutation and typically in a modern inverter would occur in a period of time less than 50 microseconds. During this interval, chokes 1 and 2 must have sufficient transient impedance to prevent a significant increase in current from the DC source.

Diodes 1, 2, 3 and 4 serve two functions. The first is to return any stored energy that may be "kicked back" from the load to the source. They also serve to prevent the choke from generating a high transient voltage immediately after commutation.

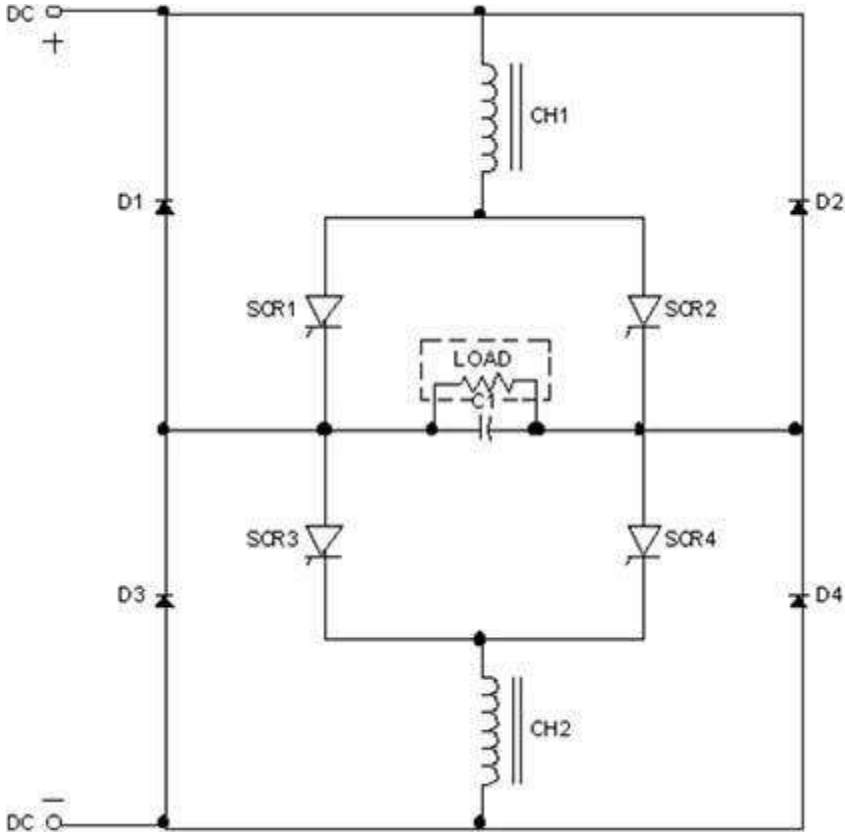

Figure: 5.14 Circuit diagram of parallel commutated inverter

Three Phase DC-AC Converters

Three phase inverters are normally used for high power applications. The advantages of a three phase inverter are:

- The frequency of the output voltage waveform depends on the switching rate of the switches and hence can be varied over a wide range.
- The direction of rotation of the motor can be reversed by changing the output phase sequence of the inverter.
- The ac output voltage can be controlled by varying the dc link voltage.

The general configuration of a three phase DC-AC inverter is shown in **Figure** Two types of control signals can be applied to the switches:

- 180° conduction
- 120° conduction

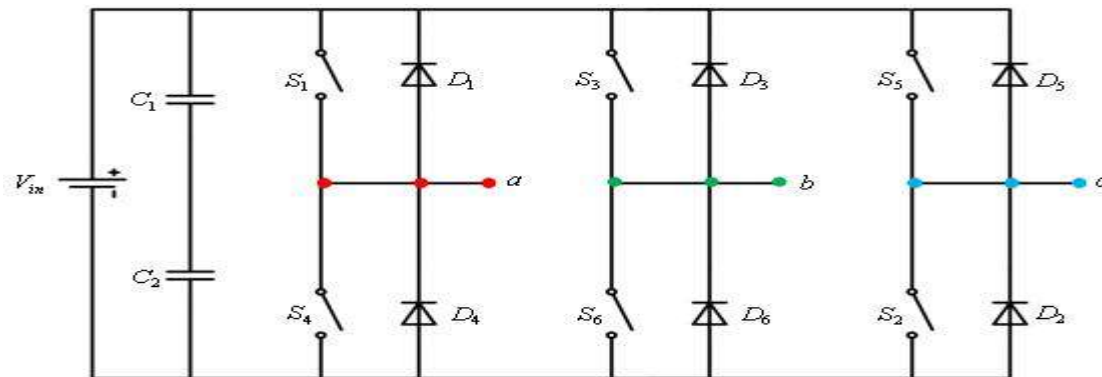

Figure: 5.15 Circuit diagram of three phase bridge inverter

180-Degree Conduction with Star Connected Resistive Load

The configuration of the three phase inverter with star connected resistive load is shown in **Figure**. The following convention is followed:

- A current leaving a node point a , b or c and entering the neutral point n is assumed to be positive.
- All the three resistances are equal, $R_a = R_b = R_c = R$.

In this mode of operation each switch conducts for 180° . Hence, at any instant of time **three switches** remain **on**. When S_1 is **on**, the terminal a gets connected to the positive terminal of input DC source. Similarly, when S_4 is **on**, terminal a gets connected to the negative terminal of input DC source. There are six possible modes of operation in a cycle and each mode is of 60° duration and the explanation of each mode is as follows:

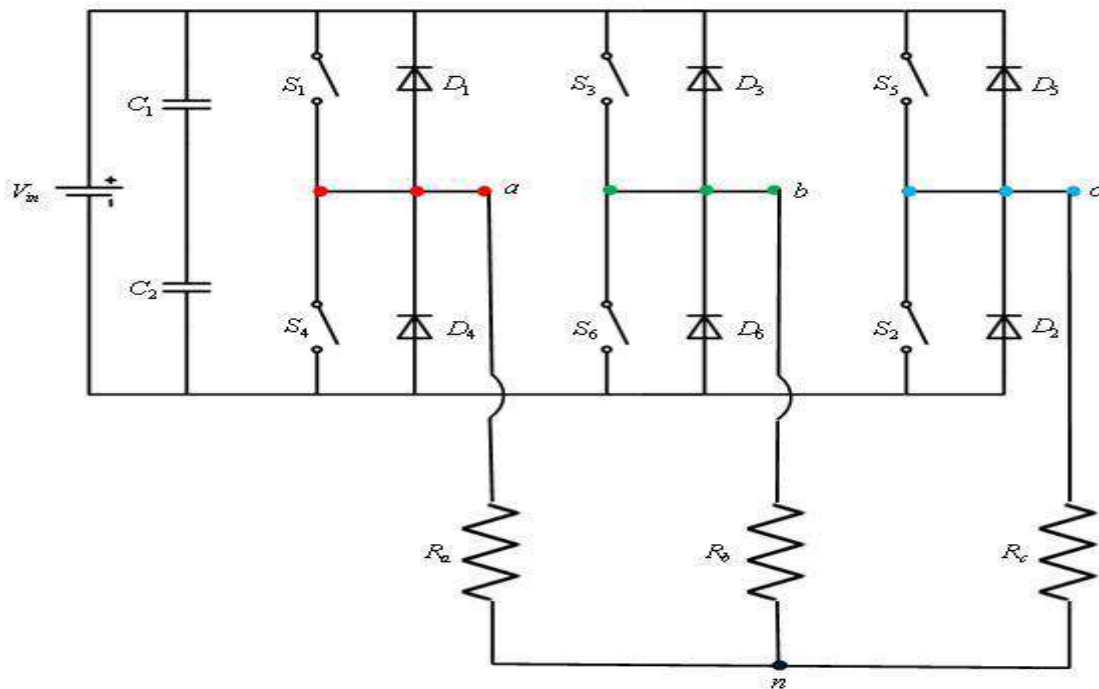

Figure: 5.16 Circuit diagram of three phase bridge inverter with star connected load

Mode 1 : In this mode the switches S_5 , S_6 and S_1 are turned **on** for time interval $0 \leq \omega t \leq \frac{\pi}{3}$. As a result of this the terminals a and c are connected to the positive terminal of the input DC source and the terminal b is connected to the negative terminal of the DC source. The current flow through R_a , R_b and R_c is shown in Figure and the equivalent circuit is shown in Figure. The equivalent resistance of the circuit shown in **Figure** is

$$R_{eq} = R + \frac{R}{2} = \frac{3R}{2} \quad (1)$$

The current i delivered by the DC input source is

$$i = \frac{V_{in}}{R_{eq}} = \frac{2 V_{in}}{3 R} \quad (2)$$

The currents i_a and i_b are

$$i_a = i_c = \frac{1 V_{in}}{3 R} \quad (3)$$

Keeping the current convention in mind, the current i_b is

$$i_b = -i = -\frac{2 V_{in}}{3 R} \quad (4)$$

Having determined the currents through each branch, the voltage across each branch is

$$v_{an} = v_{cn} = i_a R = \frac{V_m}{3}; \quad v_{bn} = i_b R = -\frac{2V_m}{3} \quad (5)$$

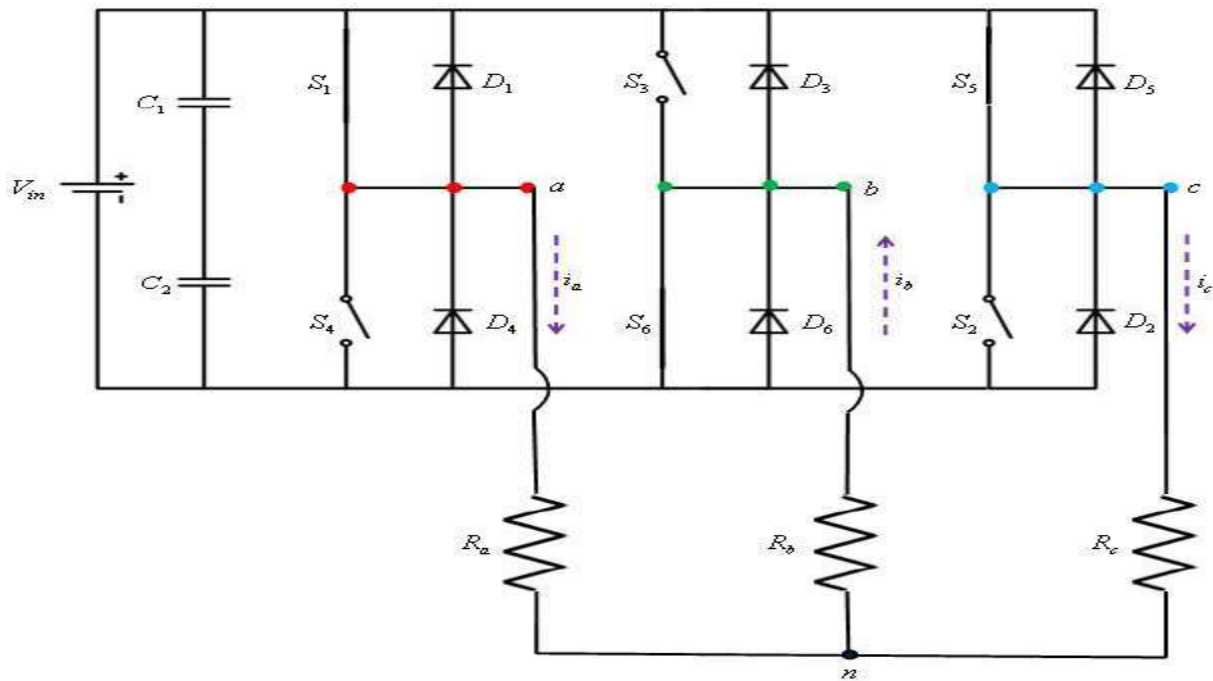

Figure: 5.17 Mode 1 operation of three phase bridge inverter with star connected load

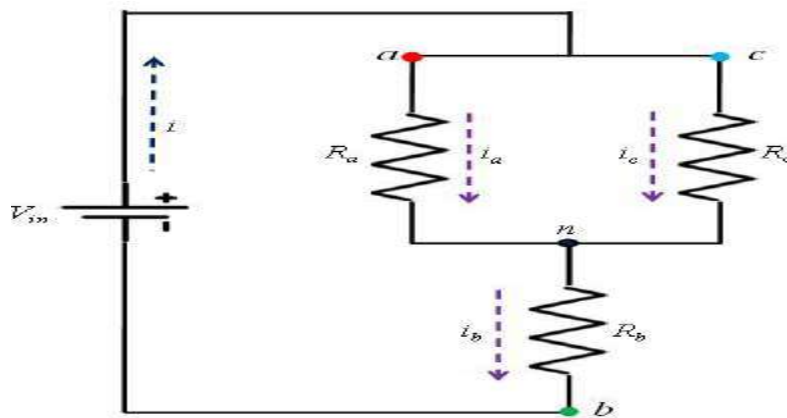

Figure: 5.18 Current flow in Mode 1 operation

Mode 2 : In this mode the switches S_6 , S_1 and S_2 are turned **on** for time interval $\frac{\pi}{3} \leq \omega t \leq \frac{2\pi}{3}$. The current flow and the equivalent circuits are shown in **Figure** and **Figure** respectively. Following the reasoning given for **mode 1**, the currents through each branch and the voltage drops are given by

$$i_b = i_c = \frac{1}{3} \frac{V_{in}}{R}; i_a = -\frac{2}{3} \frac{V_{in}}{R} \quad (6)$$

$$V_{bn} = V_{cn} = \frac{V_{in}}{3}; V_{an} = -\frac{2V_{in}}{3} \quad (7)$$

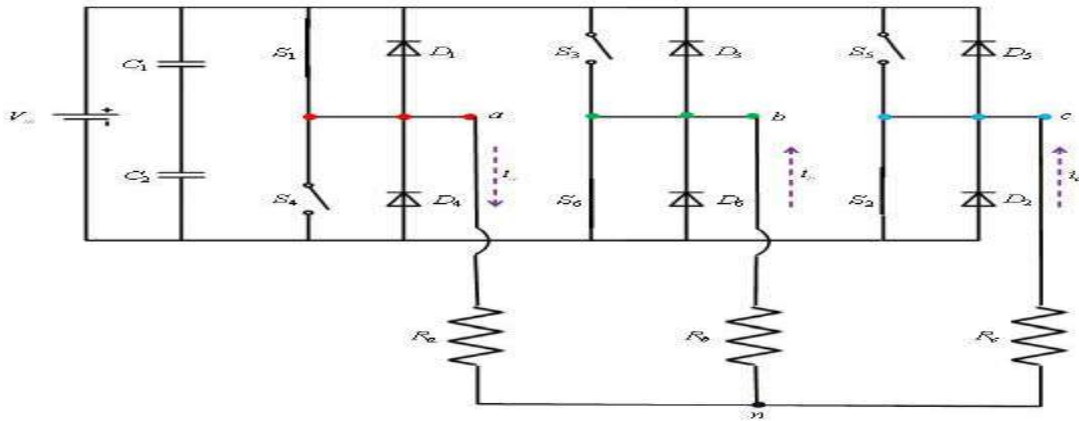

Figure: 5.19 Mode 2 operation of three phase bridge inverter with star connected load

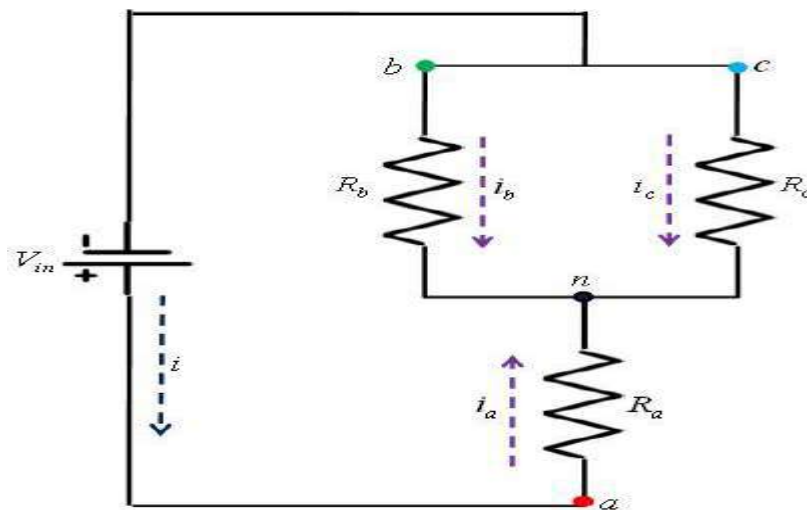

Figure: 5.20 Current flow in Mode 2 operation

Mode 3 : In this mode the switches S_1 , S_2 and S_3 are **on** for $\frac{2\pi}{3} \leq \omega t \leq \pi$. The current flow and the equivalent circuits are shown in **Figure** and **figure** respectively. The magnitudes of currents and voltages are:

$$i_a = i_b = \frac{1}{3} \frac{V_m}{R}; i_c = -\frac{2}{3} \frac{V_m}{R} \quad (8)$$

$$v_{an} = v_{bn} = \frac{V_m}{3}; v_{cn} = -\frac{2V_m}{3} \quad (9)$$

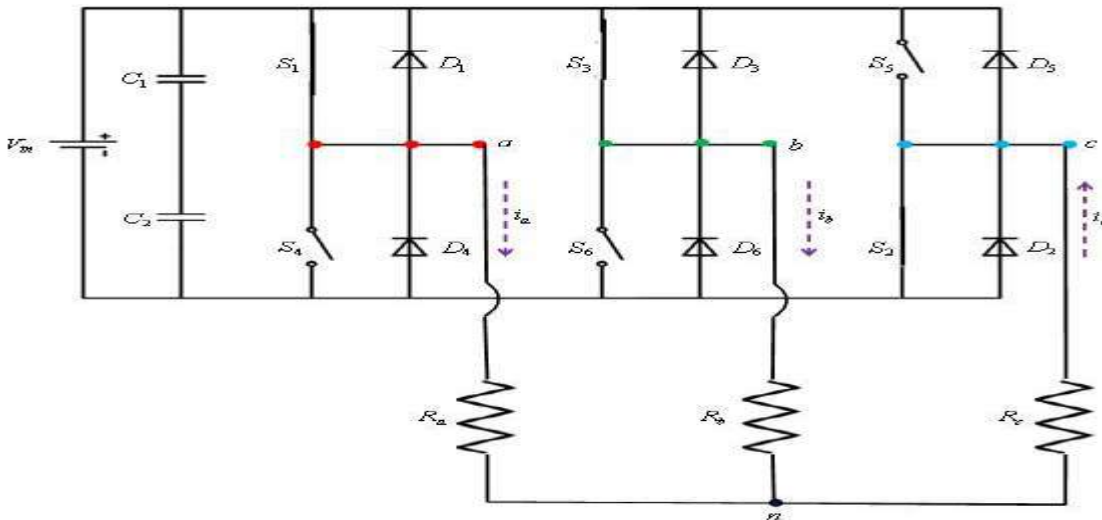

Figure: 5.21 Mode 3 operation of three phase bridge inverter with star connected load

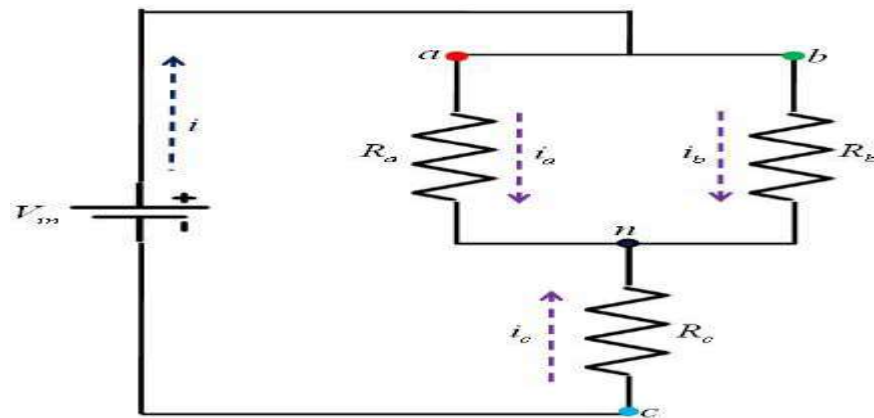

Figure: 5.23 Current flow in Mode 3 operation

For *modes 4, 5* and *6* the equivalent circuits will be same as *modes 1, 2* and *3* respectively. The voltages and currents for each mode are:

$$\left. \begin{aligned} i_a = i_c = -\frac{1}{3} \frac{V_{in}}{R}, i_b = \frac{2}{3} \frac{V_{in}}{R} \\ v_{an} = v_{cn} = -\frac{V_{in}}{3}, V_{bn} = \frac{2V_{in}}{3} \end{aligned} \right\} \text{for mode 4} \quad (10)$$

$$\left. \begin{aligned} i_b = i_c = -\frac{1}{3} \frac{V_{in}}{R}, i_a = \frac{2}{3} \frac{V_{in}}{R} \\ v_{bn} = v_{cn} = -\frac{V_{in}}{3}, V_{an} = \frac{2V_{in}}{3} \end{aligned} \right\} \text{for mode5} \quad (11)$$

$$\left. \begin{aligned} i_a = i_b = -\frac{1}{3} \frac{V_{in}}{R}, i_c = \frac{2}{3} \frac{V_{in}}{R} \\ v_{an} = v_{bn} = -\frac{V_{in}}{3}, V_{cn} = \frac{2V_{in}}{3} \end{aligned} \right\} \text{for mode 6} \quad (12)$$

The plots of the phase voltages (v_{an} , v_{bn} and v_{cn}) and the currents (i_a , i_b and i_c) are shown in **Figure**. Having known the phase voltages, the line voltages can also be determined as:

$$\begin{aligned} v_{ab} &= v_{an} - v_{bn} \\ v_{bc} &= v_{bn} - v_{cn} \\ v_{ca} &= v_{cn} - v_{an} \end{aligned} \quad (13)$$

The plots of line voltages are also shown in **Figure** and the phase and line voltages can be expressed in terms of Fourier series as:

$$\begin{aligned}
v_{an} &= \sum_{n=1,3,5,\dots}^{\infty} \frac{4V_{in}}{3n\pi} \left[1 + \sin \frac{n\pi}{2} \sin \frac{n\pi}{6} \right] \sin(n\alpha t) \\
v_{bn} &= \sum_{n=1,3,5,\dots}^{\infty} \frac{4V_{in}}{3n\pi} \left[1 + \sin \frac{n\pi}{2} \sin \frac{n\pi}{6} \right] \sin\left(n\alpha t - \frac{2n\pi}{3}\right) \\
v_{cn} &= \sum_{n=1,3,5,\dots}^{\infty} \frac{4V_{in}}{3n\pi} \left[1 + \sin \frac{n\pi}{2} \sin \frac{n\pi}{6} \right] \sin\left(n\alpha t - \frac{4n\pi}{3}\right)
\end{aligned} \tag{14}$$

$$\begin{aligned}
v_{ab} = v_{an} - v_{bn} &= \sum_{n=1,3,5,\dots}^{\infty} \frac{4V_{in}}{n\pi} \sin \frac{n\pi}{2} \sin \frac{n\pi}{3} \sin\left(n\alpha t + \frac{n\pi}{6}\right) \\
v_{bc} = v_{bn} - v_{cn} &= \sum_{n=1,3,5,\dots}^{\infty} \frac{4V_{in}}{n\pi} \sin \frac{n\pi}{2} \sin \frac{n\pi}{3} \sin\left(n\alpha t - \frac{n\pi}{2}\right) \\
v_{ca} = v_{cn} - v_{an} &= \sum_{n=1,3,5,\dots}^{\infty} \frac{4V_{in}}{n\pi} \sin \frac{n\pi}{2} \sin \frac{n\pi}{3} \sin\left(n\alpha t - \frac{7n\pi}{6}\right)
\end{aligned} \tag{15}$$

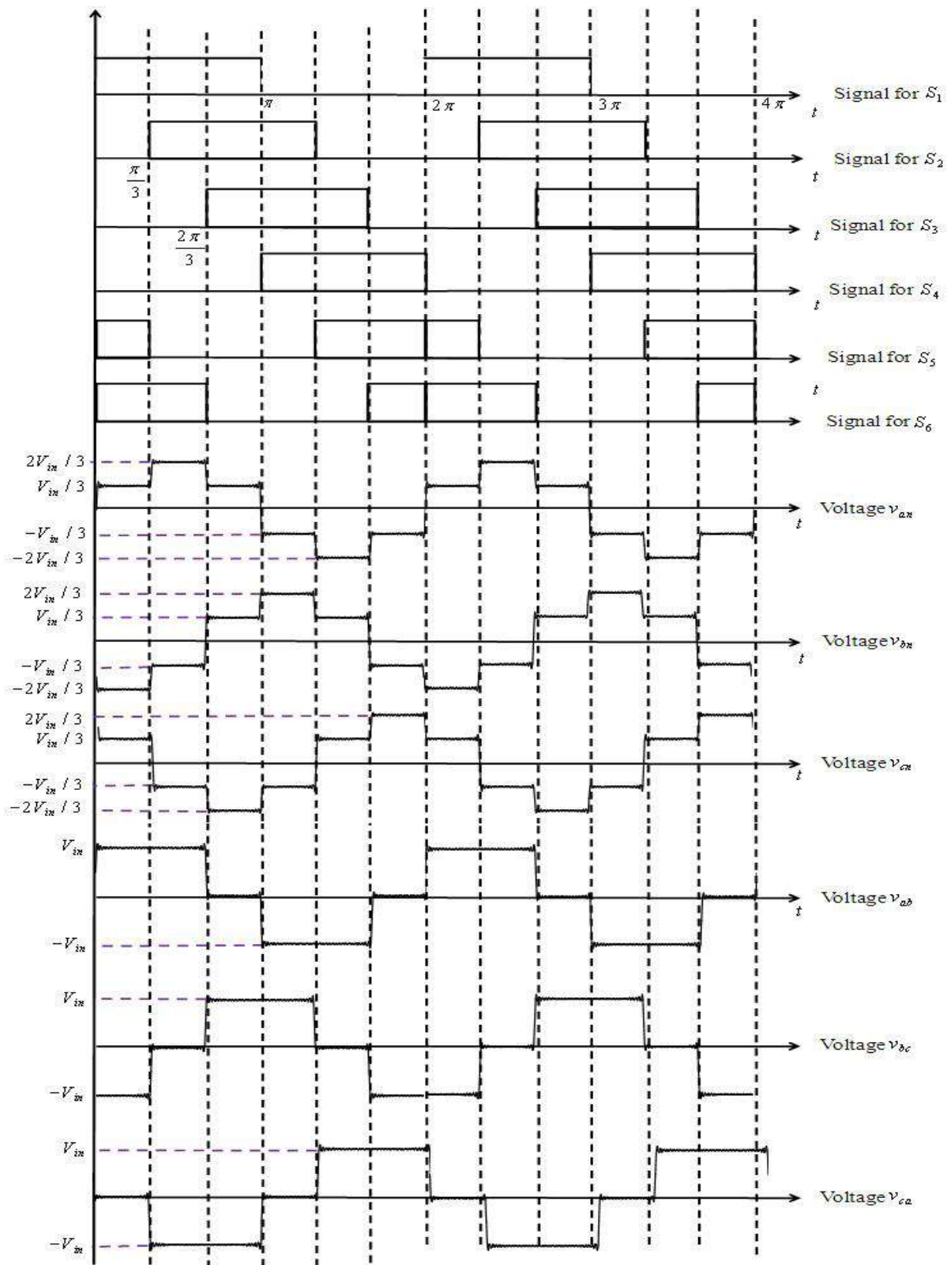

Figure: 5.24 Line and phase voltages of three phase bridge inverter

Three Phase DC-AC Converters with 120 degree conduction mode

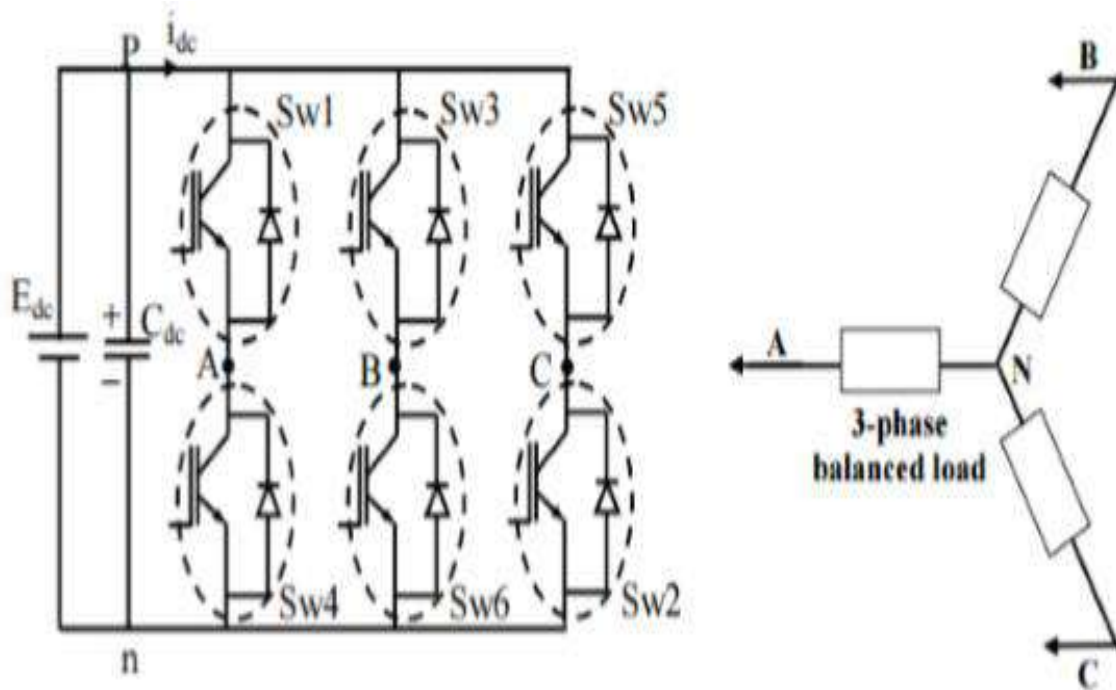

Figure: 5.25 Circuit diagram of three phase bridge inverter

120° mode of conduction

In this mode of conduction, each electronic device is in a conduction state for 120°. It is most suitable for a delta connection in a load because it results in a six-step type of waveform across any of its phases. Therefore, at any instant only two devices are conducting because each device conducts at only 120°.

The terminal A on the load is connected to the positive end while the terminal B is connected to the negative end of the source. The terminal C on the load is in a condition called floating state. Furthermore, the phase voltages are equal to the load voltages as shown below.

Phase voltages = Line voltages

$$V_{AB} = V$$

$$V_{BC} = -V/2$$

$$V_{CA} = -V/2$$

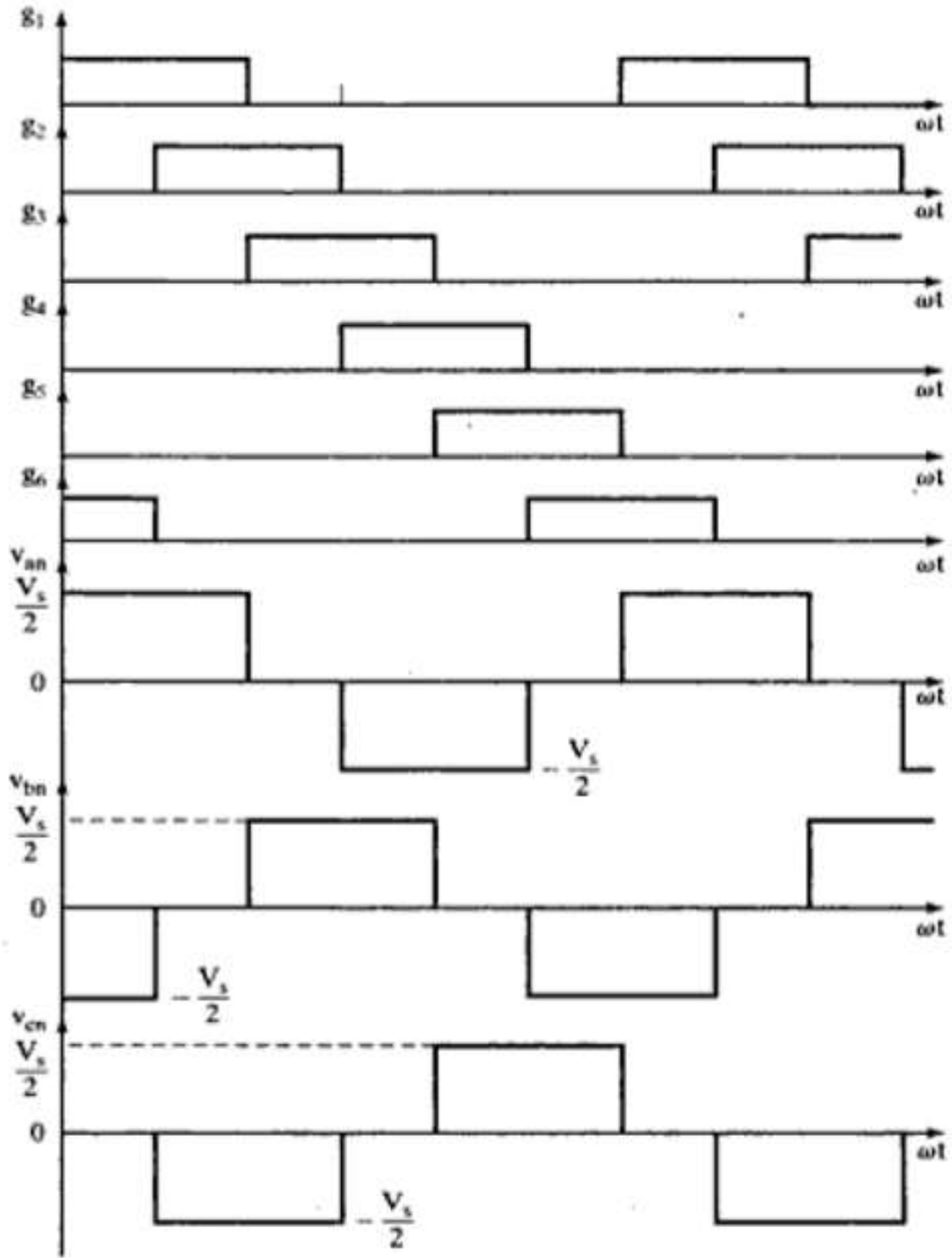

Figure: 5.26 Line and phase voltages of three phase bridge inverter

Voltage control techniques for inverters

Pulse width modulation techniques

PWM is a technique that is used to reduce the overall harmonic distortion (THD) in a load current. It uses a pulse wave in rectangular/square form that results in a variable average waveform value $f(t)$, after its pulse width has been modulated. The time period for modulation is given by T . Therefore, waveform average value is given by

$$y = \frac{1}{T} \int_0^T f(t) dt$$

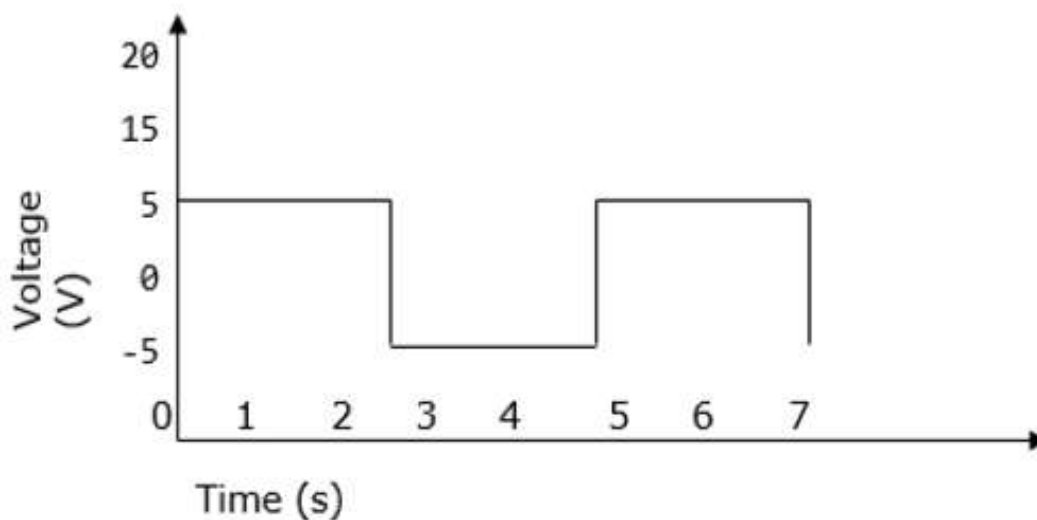

Figure: 5.27 Square waveform used for PWM technique

Sinusoidal Pulse Width Modulation

In a simple source voltage inverter, the switches can be turned ON and OFF as needed. During each cycle, the switch is turned on or off once. This results in a square waveform. However, if the switch is turned on for a number of times, a harmonic profile that is improved waveform is obtained.

The sinusoidal PWM waveform is obtained by comparing the desired modulated waveform with a triangular waveform of high frequency. Regardless of whether the voltage of the signal is smaller or larger than that of the carrier waveform, the resulting output voltage of the DC bus is either negative or positive.

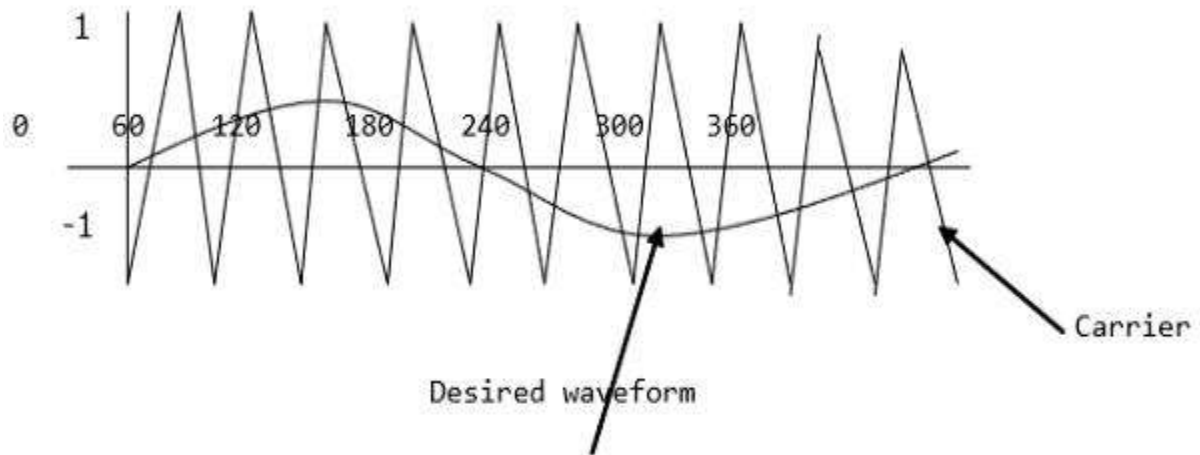

Figure: 5.28 Sinusoidal PWM waveform

The sinusoidal amplitude is given as A_m and that of the carrier triangle is given as A_c . For sinusoidal PWM, the modulating index m is given by A_m/A_c .

Modified Sinusoidal Waveform PWM

A modified sinusoidal PWM waveform is used for power control and optimization of the power factor. The main concept is to shift current delayed on the grid to the voltage grid by modifying the PWM converter. Consequently, there is an improvement in the efficiency of power as well as optimization in power factor.

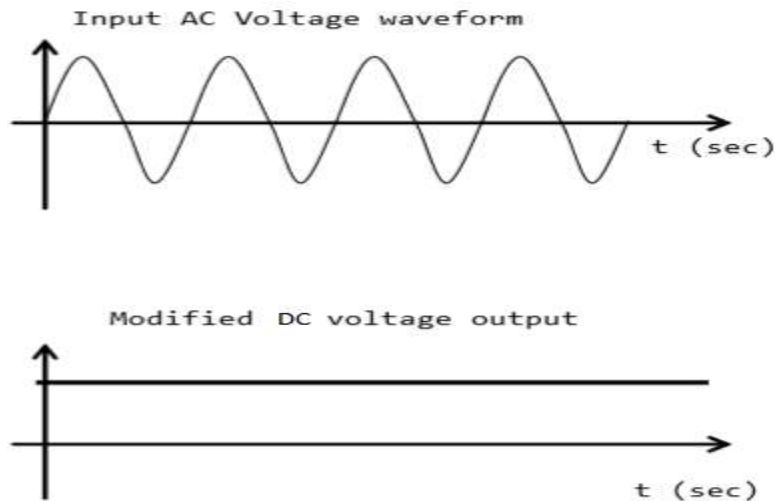

Figure: 5.29 Modified sinusoidal PWM waveform

Multiple PWM

The multiple PWM has numerous outputs that are not the same in value but the time period over which they are produced is constant for all outputs. Inverters with PWM are able to operate at high voltage output.

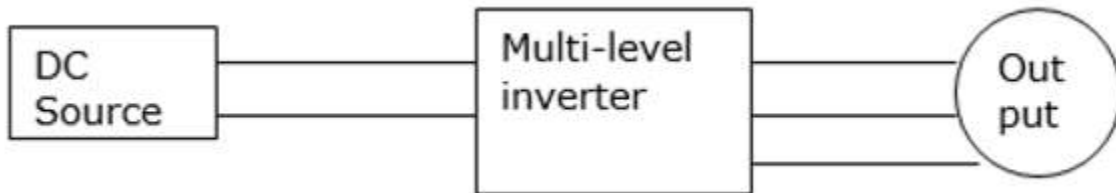

Figure: 5.30 Block diagram of multiple PWM technique

The waveform below is a sinusoidal wave produced by a multiple PWM

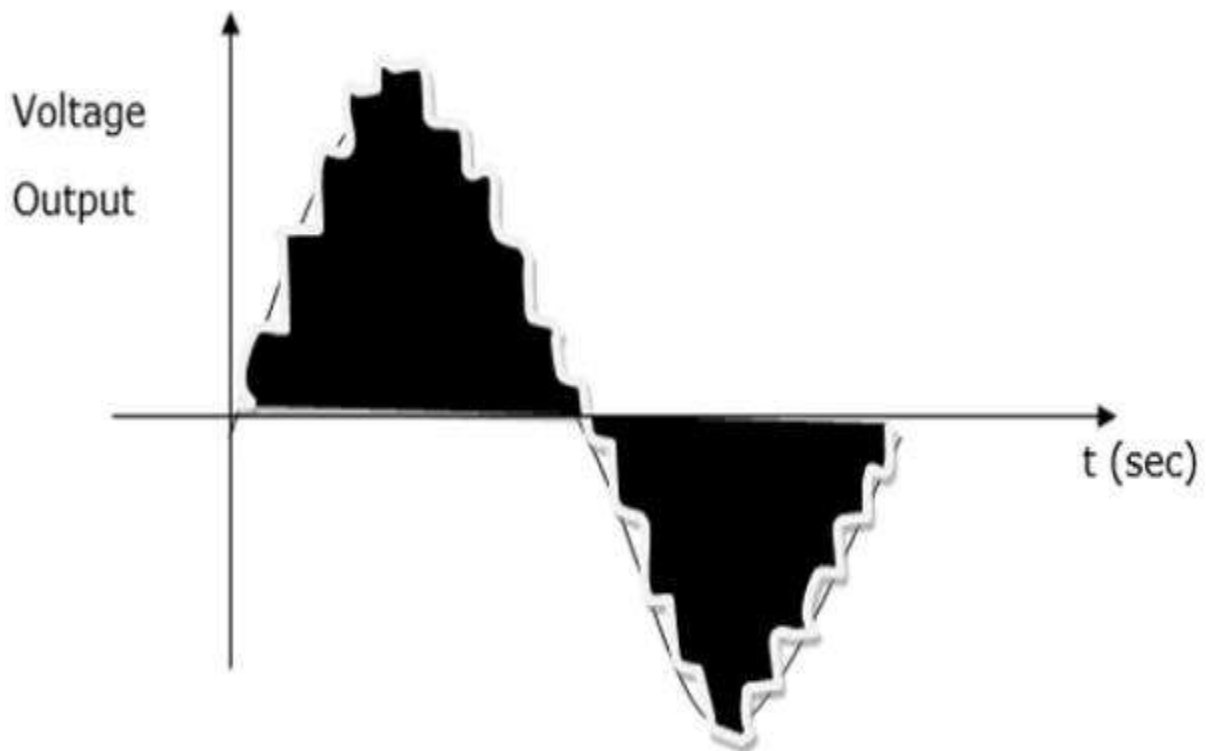

Figure: 5.31 Waveform of multiple PWM technique

Voltage and Harmonic Control

A periodic waveform that has frequency, which is a multiple integral of the fundamental power with frequency of 60Hz is known as a harmonic. Total harmonic distortion (THD) on the other hand refers to the total contribution of all the harmonic current frequencies.

Harmonics are characterized by the pulse that represents the number of rectifiers used in a given circuit. It is calculated as follows

$$h=(n \times P)+1 \text{ or } -1$$

Where **n** – is an integer 1, 2, 3, 4...n

P – Number of rectifiers

Harmonics have an impact on the voltage and current output and can be reduced using isolation transformers, line reactors, redesign of power systems and harmonic filters.

Operation of sinusoidal pulse width modulation

The sinusoidal PWM (SPWM) method also known as the triangulation, sub harmonic, or sub oscillation method, is very popular in industrial applications. The SPWM is explained with reference to Figure, which is the half-bridge circuit topology for a single-phase inverter.

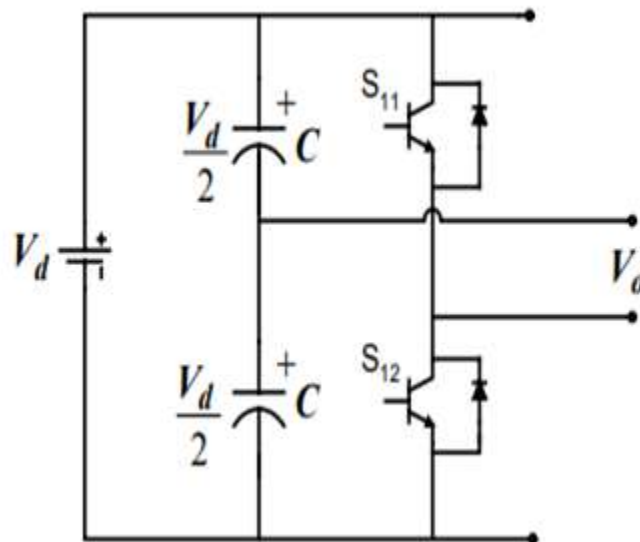

Figure: 5.32 schematic diagram of Half bridge PWM inverter

For realizing SPWM, a high-frequency triangular carrier wave is compared with a sinusoidal reference of the desired frequency. The intersection of and waves determines the switching instants and commutation of the modulated pulse. The PWM scheme is illustrated in Figure, in which v_c the peak value of triangular carrier wave and v_r is that of the reference, or modulating signal. The figure shows the triangle and modulation signal with some arbitrary frequency and magnitude. In the inverter of Figure the switches and are controlled based on the comparison of control signal and the triangular wave which are mixed in a comparator. When sinusoidal wave has magnitude higher than the triangular wave the comparator output is high, otherwise it is low.

$$v_r > v_c \quad S_{11} \text{ is on, } V_{out} = \frac{V_d}{2}$$

and

$$v_r < v_c \quad S_{12} \text{ is on, } V_{out} = -\frac{V_d}{2}$$

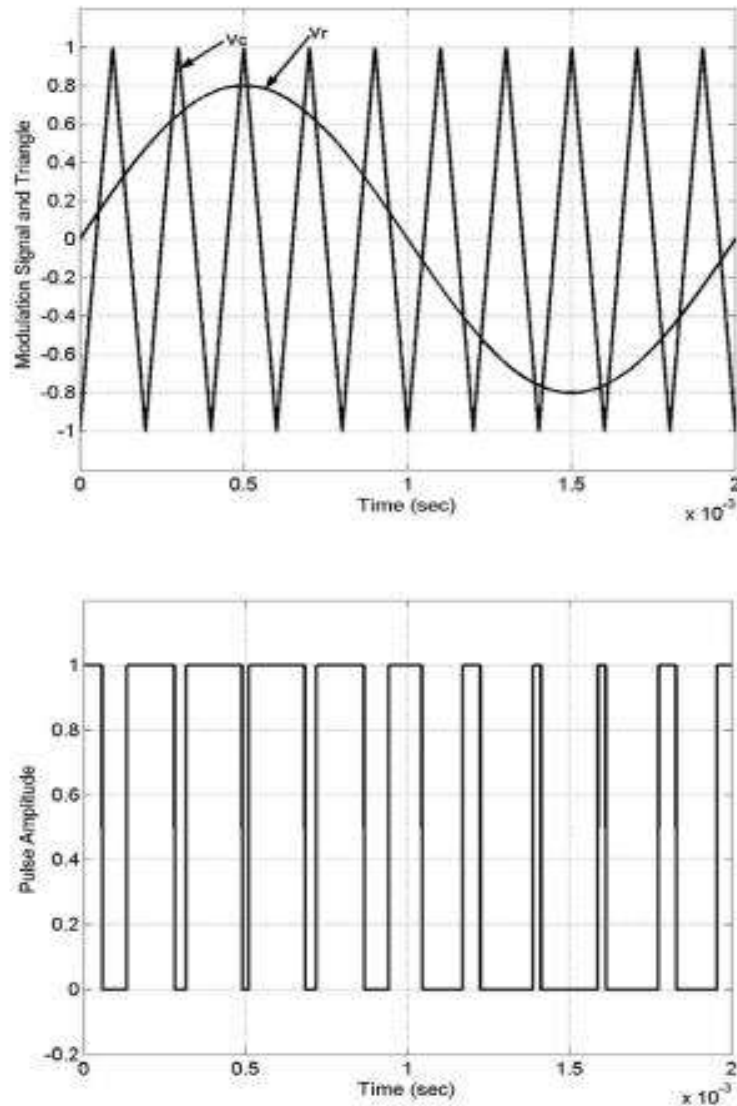

Figure: 5.33 Sine-Triangle Comparison and switching pulses of half bridge PWM inverter

The comparator output is processed in a trigger pulse generator in such a manner that the output voltage wave of the inverter has a pulse width in agreement with the comparator output pulse width. The magnitude ratio of V_r/V_c is called the modulation index (MI) and it controls the harmonic content of the output voltage waveform. The magnitude of the fundamental component of the output voltage is proportional to MI. The amplitude of the triangular wave is generally kept constant. The frequency modulation ratio is defined as

$$M_F = \frac{f_r}{f_m}$$

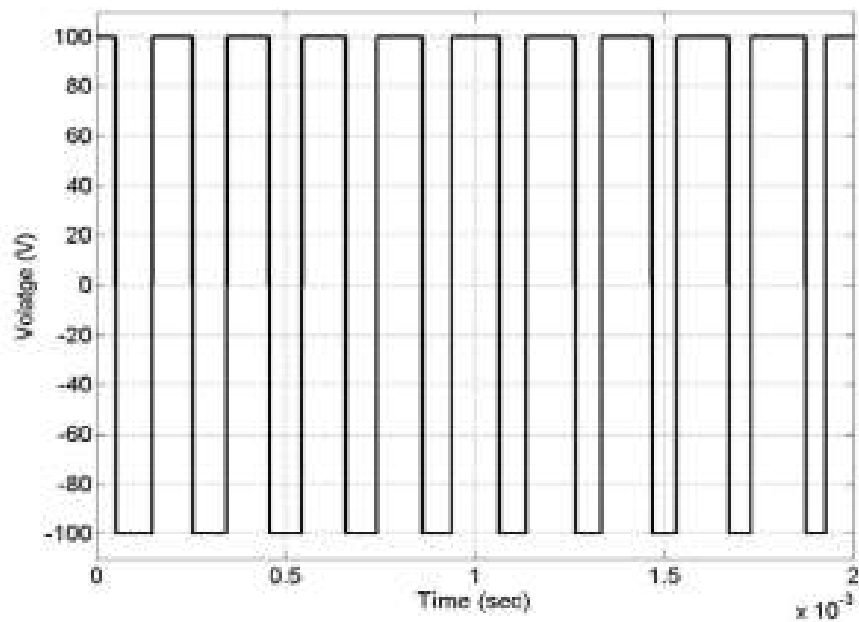

Figure: 5.34 Output voltage of the Half-Bridge inverter

Operation of current source inverter with ideal switches

Single-phase Current Source Inverter

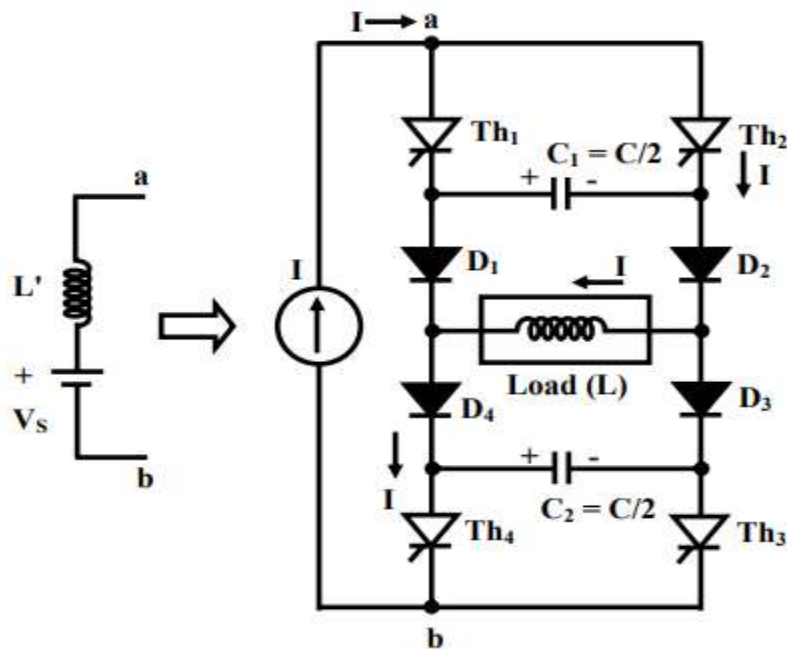

Figure: 5.35 Single phase current source inverter (CSI) of ASCI type

The circuit of a Single-phase Current Source Inverter (CSI) is shown in Fig. 5.35. The type of operation is termed as Auto-Sequential Commutated Inverter (ASCI). A constant current source is assumed here, which may be realized by using an inductance of suitable value, which must be high, in series with the current limited dc voltage source. The thyristor pairs, Th1 & Th3, and Th2 & Th4, are alternatively turned ON to obtain a nearly square wave current waveform. Two commutating capacitors – C1 in the upper half, and C2 in the lower half, are used. Four diodes, D1–D4 are connected in series with each thyristor to prevent the commutating capacitors from discharging into the load. The output frequency of the inverter is controlled in the usual way, i.e., by varying the half time period, (T/2), at which the thyristors in pair are triggered by pulses being fed to the respective gates by the control circuit, to turn them ON, as can be observed from the waveforms (Fig. 5.36). The inductance (L) is taken as the load in this case, the reason(s) for which need not be stated, being well known. The operation is explained by two modes.

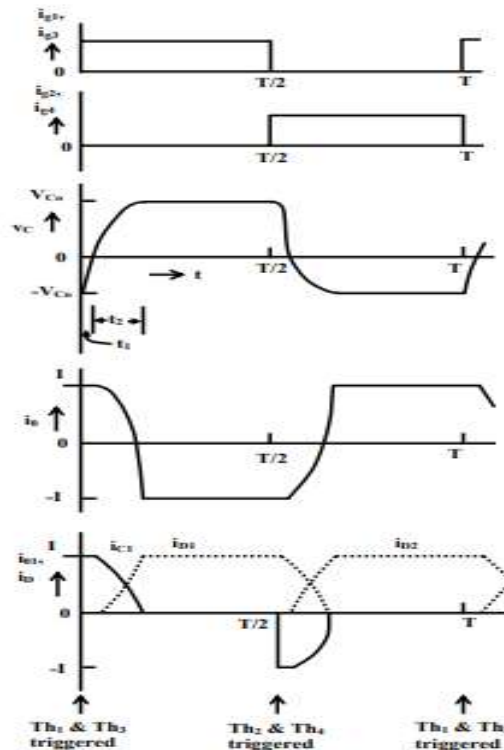

Figure: 5.36 output waveforms of Single phase current source inverter

Mode I: The circuit for this mode is shown in Fig. 5.37. The following are the assumptions. Starting from the instant, , the thyristor pair, Th - t = 0 2 & Th4, is conducting (ON), and the current (I) flows through the path, Th2, D2, load (L), D4, Th4, and source, I. The commutating capacitors are initially charged equally with the polarity as given, i.e., . This mans that both capacitors have right hand plate positive and left hand plate negative. If two capacitors are not charged initially, they have to pre-charge.

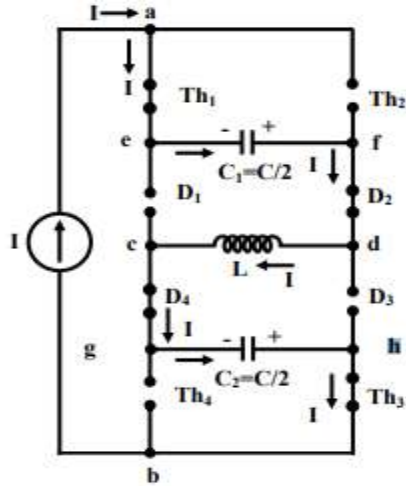

Figure: 5.37 Mode I operation of CSI

Mode II: The circuit for this mode is shown in Fig. 5.38. Diodes, D2 & D4, are already conducting, but at $t = t_1$, diodes, D1 & D3, get forward biased, and start conducting. Thus, at the end of time t_1 , all four diodes, D1–D4 conduct. As a result, the commutating capacitors now get connected in parallel with the load (L).

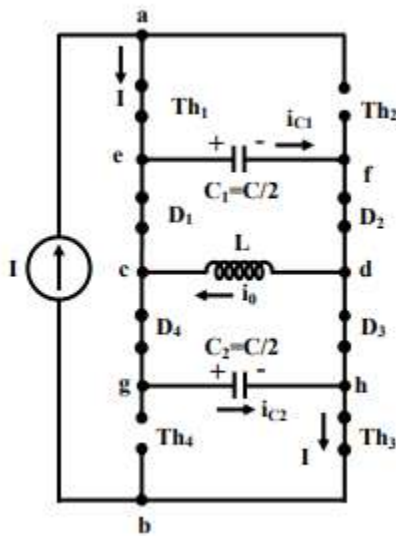

Figure: 5.38 Mode II operation of CSI

Load Commutated CSI

Two commutating capacitors, along with four diodes, are used in the circuit for commutation from one pair of thyristors to the second pair. Earlier, also in VSI, if the load is capacitive, it was shown that forced commutation may not be needed. The operation of a single-phase CSI with capacitive load (Fig. 5.39) is discussed here. It may be noted that the capacitor, C is assumed to be in parallel with resistive load (R). The capacitor, C is used for storing the charge, or voltage, to be used to force-commutate the conducting thyristor pair as will be shown. As was the case in the last lesson, a constant current source, or a voltage source with large inductance, is used as the input to the circuit.

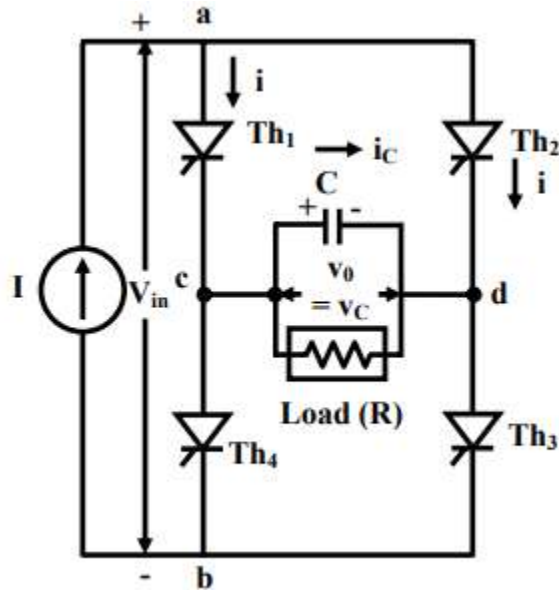

Figure: 5.39 Circuit diagram of load commutated CSI

The power switching devices used here is the same, i.e. four Thyristors only in a full- bridge configuration. The positive direction for load current and voltage is shown in Fig. 5.40 Before $t = 0$, the capacitor voltage is V_1 , i.e. the capacitor has left plate negative and right plate positive. At that time, the thyristor pair, Th_2 & Th_4 was conducting. When (at $t = 0$), the thyristor pair, Th_1 & Th_3 is triggered by the pulses fed at the gates, the conducting thyristor pair, Th_2 & Th_4 is reverse biased by the capacitor voltage $C = -V_1$, and turns off immediately. The current path is through Th_1 , load (parallel combination of R & C), Th_3 , and the source. The current in the thyristors is I_{Ti} , the output current is

$$I_{ac} = I$$

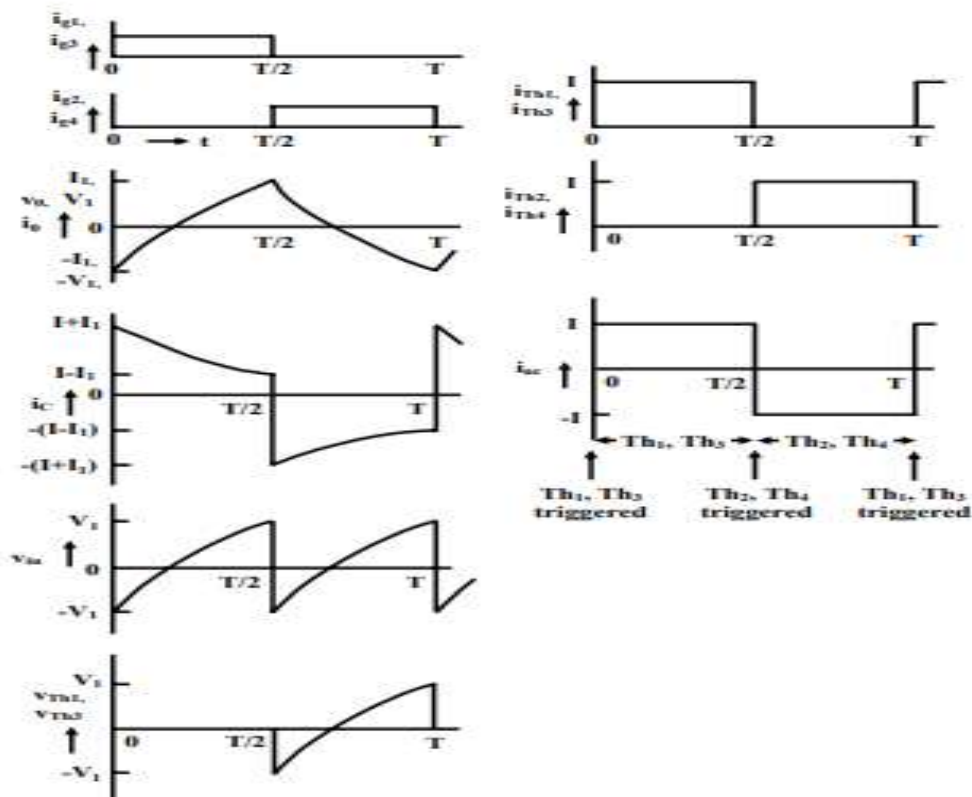

Figure: 5.40 Voltage and current waveforms of load commutated CSI

Numerical Problems

1. A single-phase half bridge inverter has a resistive load of 2.4Ω and the d.c. input voltage of 48 V . Determine:-
 - (i) RMS output voltage at the fundamental frequency
 - (ii) Output power P_0
 - (iii) Average and peak currents of each transistor
 - (iv) Peak blocking voltage of each transistor.
 - (v) Total harmonic distortion and distortion factor.
 - (vi) Harmonic factor and distortion factor at the lowest order harmonic.

Solution:

(i) RMS output voltage of fundamental frequency, $E_1 = 0.9 \times 48 = 43.2 \text{ V}$.

(ii) RMS output voltage, $E_{\text{orms}} = E = 48 \text{ V}$.

Output power = $E^2/R = (48)^2/2.4 = 960 \text{ W}$.

(iii) Peak transistor current = $I_p = Ed/R = 48/2.4 = 20$ A.

Average transistor current = $I_p/2 = 10$ A.

(iv) Peak reverse blocking voltage,

$VBR = 48$ V.

(v) RMS harmonic voltage

$$\begin{aligned} E_n &= \left[\sum_{n=3,5,7}^8 E_n^2 \right]^{1/2} \\ &= (E_{\text{orms}}^2 - E_{1\text{rms}}^2)^{1/2} \\ &= [(48)^2 - (43.2)^2]^{1/2} \\ &= 20.92 \text{ V.} \end{aligned}$$

$$\therefore \text{THD} = \frac{20.92}{43.2} = 48.43\%$$

$$\begin{aligned} \text{(vi) D.F.} &= \frac{\left[\sum_{n=3,5,7}^{\infty} (E_n/n^2)^2 \right]^{1/2}}{0.9} \\ &= \frac{0.03424}{0.9} = 3.8\% \end{aligned}$$

(vii) Lowest order harmonic is the third harmonic. RMS value of third harmonic is

$$E_{3\text{rms}} = E_{1\text{rms}}/3$$

$$\therefore \text{H.F}_3 = E_{3\text{rms}}/E_{1\text{rms}} = 33.33\%$$

$$\begin{aligned} \text{and D.F.}_3 &= (E_{3\text{rms}}/3^2)/E_{1\text{rms}} \\ &= 1/27 = 3.704\%. \end{aligned}$$

2. A single phase full bridge inverter has a resistive load of $R = 10 \Omega$ and the input voltage V_{dc} of 100 V. Find the average output voltage and rms output voltage at fundamental frequency.
3. A single PWM full bridge inverter feeds an RL load with $R=10\Omega$ and $L= 10$ mH. If the source voltage is 120V, find out the total harmonic distortion in the output voltage and in the load current. The width of each pulse is 120° and the output frequency is 50Hz.