

UNIT: I**INTRODUCTION TO INSTRUMENTS****Introduction:**

The measurement of any quantity plays very important role not only in science but in all branches of engineering, medicine and in almost all the human day to day activities.

The technology of measurement is the base of advancement of science. The role of science and engineering is to discover the new phenomena, new relationships, the laws of nature and to apply these discoveries to human as well as other scientific needs. The science and engineering is also responsible for the design of new equipments. The operation, control and the maintenance of such equipments and the processes is also one of the important functions of the science and engineering branches. All these activities are based on the proper measurement and recording of physical, chemical, mechanical, optical and many other types of parameters.

measuring instrument and measurement procedure which minimizes the error. The measuring instrument should not affect the quantity to be measured.

An electronic instrument is the one which is based on electronic or electrical principles for its measurement function. The measurement of any electronic or electrical quantity or variable is termed as an electronic measurement.

Advantages of Electronic Measurement

The advantages of an electronic measurement are

1. Most of the quantities can be converted by transducers into the electrical or electronic signals.
2. An electrical or electronic signal can be amplified, filtered, multiplexed, sampled and measured.
3. The measurement can easily be obtained in or converted into digital form for automatic analysis and recording.
- 4 The measured signals can be transmitted over long distances with the help of cables or radio links, without any loss of information.
5. Many measurements can be carried either simultaneously or in rapid succession.
6. Electronic circuits can detect and amplify very weak signals and can measure the events of very short duration as well.

7. Electronic measurement makes possible to build analog and digital signals. The digital signals are very much required in computers. The modern development in science and technology are totally based on computers.
8. Higher sensitivity, low power consumption and a higher degree of reliability are the important features of electronic instruments and measurements. But, for any measurement, a well defined set of standards and calibration units is essential. This chapter provides an introduction to different types of errors in measurement, the characteristics of an instrument and different calibration standards.

Functional elements of an instruments:

Any instrument or a measuring system can be described in general with the help of a block diagram. While describing the general form of a measuring system, it is not necessary to go into the details of the physical aspects of a specific instrument. The block diagram indicates the necessary elements and their functions in a general measuring system. The entire operation of an instrument can be studied in terms of these functional elements. The Fig. 1.1 shows the block

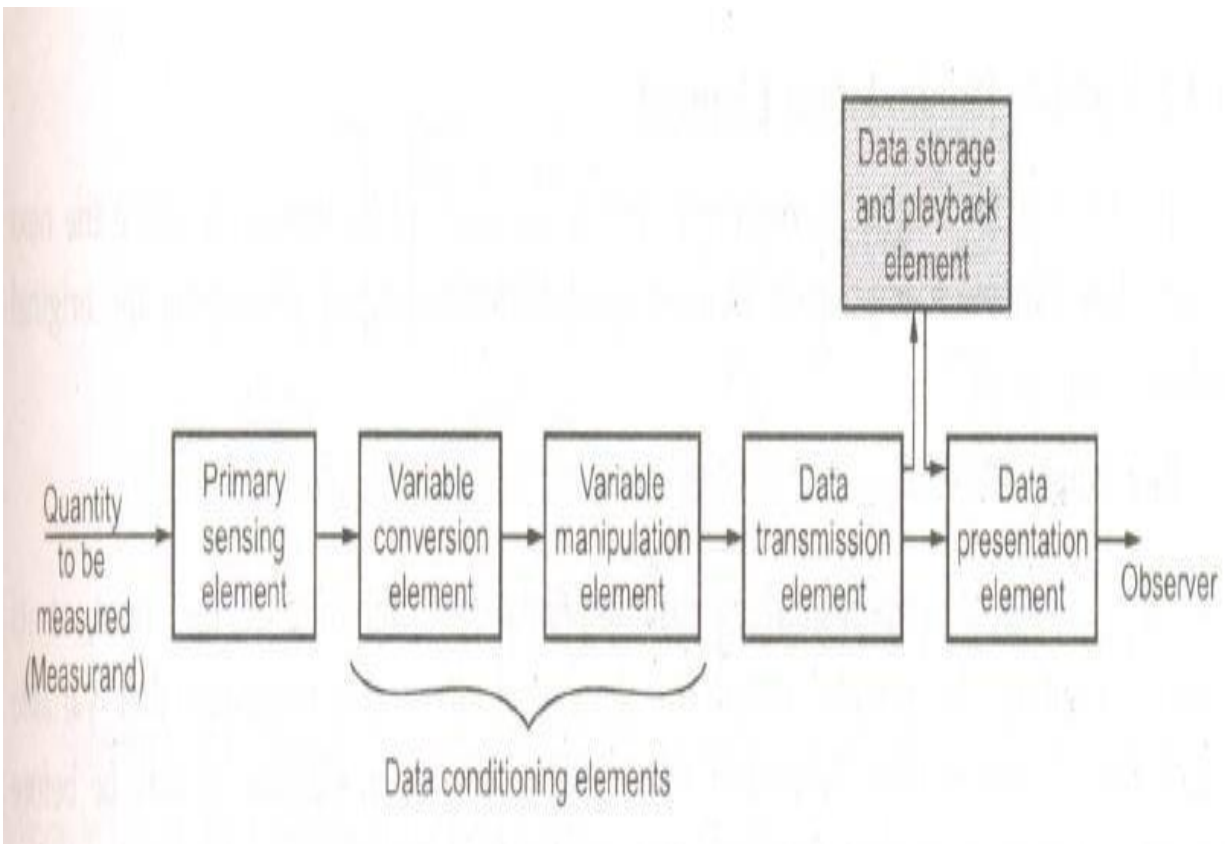

diagram instrument can be studied interms of these functional elements. The Fig. 1.1 shows the block

Calibration:

Calibration is the process of making an adjustment or marking a scale so that the readings of an instrument agree with the accepted and the certified standard.

The calibration offers a guarantee to the device or instrument that it is operating with required accuracy, under the stipulated environmental conditions. It creates the confidence of using the properly calibrated instrument, in user's mind. The periodic calibration of an instrument is very much necessary.

The calibration characteristics can be determined by applying known values of quantities to be measured and recording the corresponding output of the instrument. Such output values are then compared with the input, to determine the error. Such a record obtained from calibration is called calibration record. It is generally recorded in the tabular form. If it is represented in the graphical form, it is called calibration curve. Such a calibration record or calibration curve is useful to obtain the performance characteristics of an instrument. The performance of the instrument is not guaranteed by the calibration. It only indicates whether the performance of the instrument is meeting the accuracy and range specification or not. If the device has been repaired, aged, adjusted or modified, then recalibration is carried out.

Such a record obtained from calibration is called calibration record. It is generally recorded in the tabular form. If it is represented in the graphical form, it is called calibration curve. Such a calibration record or calibration curve is useful to obtain the performance characteristics of an instrument. The performance of the instrument is not guaranteed by the calibration. It only indicates whether the performance of the instrument is meeting the accuracy and range specification or not. If the device has been repaired, aged, adjusted or modified, then recalibration is carried out.

The calibration offers a guarantee to the device or instrument that it is operating with required accuracy, under the stipulated environmental conditions. It creates the confidence of using the properly calibrated instrument, in user's mind. The periodic calibration of an instrument is very much necessary.

Static characteristics:

As mentioned earlier, the static characteristics are defined for the instruments which measure the quantities which do not vary with time. The various static characteristics are accuracy, precision, resolution, error, sensitivity, threshold, reproducibility, zero drift, stability and linearity.

Accuracy:

It is the degree of closeness with which the instrument reading approaches the true value of the quantity to be measured. It denotes the extent to which we approach the actual value of the quantity. It indicates the ability of instrument to indicate the true value of the quantity. The accuracy can be expressed in the following ways.

1) Accuracy as 'Percentage of Full Scale Reading' : In case of instruments having uniform scale, the accuracy can be expressed as percentage of full scale reading.

For example, the accuracy of an instrument having full scale reading of 50 units may be expressed as $\pm 0.1\%$ of full scale reading. From this accuracy indication, practically accuracy is expressed in terms of limits of error. So for the accuracy limits specified above, there will be ± 0.05 units error in any measurement. So for a reading of 50 units, there will be error of ± 0.05 units i.e. $\pm 0.1\%$ while for a reading of 25 units, there will be error of ± 0.05 units in the reading i.e. $\pm 0.2\%$. Thus as reading decreases, error in measurement is ± 0.05 units but net percentage error is more. Hence, specification of accuracy in this manner is highly misleading.

2) Accuracy as 'Percentage of True Value' : This is the best method of specifying the accuracy. It is to be specified in terms of the true value of quantity being measured. For example, it can be specified as $\pm 0.1\%$ of true value. This indicates that in such cases, as readings get smaller, error also gets reduced. Hence accuracy of the instrument is better than the instrument for which it is specified as percent of full scale reading.

3) Accuracy as 'Percentage of Scale Span' : For an instrument, if a_m is the maximum point for which scale is calibrated, i.e. full scale reading and a_{min} is the lowest reading on scale. Then $(a_m - a_{min})$ is called scale span or span of the instrument. Accuracy of the instrument can be specified as percent of such scale span. Thus for an instrument having range from 25 units to 225 units, it can be specified as $\pm 0.2\%$ of the span i.e. $\pm [(0.2/100) \times (225 - 25)]$ which is ± 0.4 units error

4) Point Accuracy: Such an accuracy is specified at only one particular point of scale. It does not give any information about the accuracy at any other point on the scale. The general accuracy of an instrument cannot be specified, in this manner. But the general accuracy can be specified by providing a table of the point accuracy values calculated at various points throughout the entire range of the instrument.

Precision:

It is the measure of consistency or repeatability of measurements.

Let us see the basic difference between accuracy and precision. Consider an instrument on which, readings upto 1/1000th of unit can be measured. But the instrument has large zero adjustment error. Now every time reading is taken, it can be taken down upto 1/1000th of unit. So as the readings agree with each other, we say that the instrument is highly precise. But, though the readings are precise upto 1/1000th of unit, the readings are inaccurate due to large zero adjustment error. Every reading will be inaccurate, due to such error. Thus a precise instrument may not be accurate. Thus the precision means sharply or clearly defined and the readings agree among themselves. But there is no guarantee that readings are accurate. An instrument having zero error, if calibrated properly, can give accurate readings but in that case still, the readings can be obtained down upto 1/1000th of unit only. Thus accuracy can be improved by calibration but not the precision of the instrument.

The precision is composed of two characteristics:

- Conformity and
- Number of significant figures.

Conformity:

Consider a resistor having true value as 2385692 Ω , which is being measured by an ohmmeter. Now, the meter is consistently measuring the true value of the resistor. But the reader, can read consistently, a value as 2.4 M Ω due to nonavailability of proper scale. The value 2.4 M Ω is estimated by the reader from the available scale. There are no deviations from the observed value. The error created due to the limitation of the scale reading is a precision error.

The example illustrates that the conformity is a necessary, but not sufficient condition for precision. Similarly, precision is necessary but not the sufficient condition for accuracy.

Significant Figures:

The precision of the measurement is obtained from the number of significant figures, in which the reading is expressed. The significant figures convey the actual information about the magnitude and the measurement precision of the quantity.

The precision can be mathematically expressed as :

$$P = 1 - \left| \frac{X_n - \bar{X}_n}{\bar{X}_n} \right|$$

where

P = Precision

X_n = Value of n^{th} measurement

\bar{X}_n = Average of the set of measured values

Example:

The table shows the set of 5 measurements recorded in a laboratory. Calculate the precision of the 3rd measurement

Measurement Number	Value of Measurement
1	49
2	51
3	52
4	50
5	49

Solution : The average value for the set of measurements is,

$$\bar{X}_n = \frac{\text{Sum of the readings}}{\text{Number of readings}} = \frac{251}{5} = 50.2$$

The value of 3rd measurement is $X_n = 52$ where $n = 3$

$$\therefore P = 1 - \left| \frac{X_n - \bar{X}_n}{\bar{X}_n} \right| = 1 - \left| \frac{52 - 50.2}{50.2} \right| = 0.964 \text{ i.e. } 96.4 \%$$

This is the precision of the 3rd measurement.

Errors:

The most important static characteristics of an instrument is its accuracy, which is generally expressed in terms of the error called static error.

Mathematically it can be expressed as, $e = A_t - A_m$

where

e = Error

A_m = Measured value of the quantity

A_t = True value of the quantity

In this expression, the error denoted as e is also called absolute error. The absolute error does not indicate precisely the accuracy of the measurements. For example, absolute error of ± 1 V is negligible when the voltage to be measured is of the order of 1000 V but the same error of ± 1 V becomes significant when the voltage under measurement is 5 V or so. Hence, generally instead of specifying absolute error, the relative or percentage error is specified.

The calibration offers a guarantee to the device or instrument that it is operating with required accuracy, under the stipulated environmental conditions. It creates the confidence of using the properly calibrated instrument, in user's mind. The periodic calibration of an instrument is very much necessary.

Mathematically, the **relative error** can be expressed as,

$$e_r = \frac{\text{Absolute Error}}{\text{True value}} = \frac{\text{True value} - \text{Measured value}}{\text{True value}}$$

$$= \frac{A_t - A_m}{A_t}$$

The percentage relative error is expressed as,

$$\% e_r = \frac{A_t - A_m}{A_t} \times 100$$

From the **relative percentage error**, the accuracy can be mathematically expressed as,

$$A = 1 - e_r = 1 - \left| \frac{A_t - A_m}{A_t} \right|$$

where A = Relative accuracy

and

$$a = A \times 100 \%$$

where a = Percentage accuracy

The error can also be expressed as a percentage of full scale reading as,

$$\text{Error as a percentage of full scale reading} = \frac{A_t - A_m}{\text{f.s.d.}} \times 100$$

where f.s.d. = Full scale deflection

If the calibration curve is not linear as shown in the Fig. 1.3 (b), then the sensitivity varies with the input. The sensitivity is always expressed by the manufacturers as the ratio of the magnitude of quantity being measured to the magnitude of the response. Actually, this definition is the reciprocal of the sensitivity is called inverse sensitivity or deflection factor. But manufacturers call this inverse sensitivity as asensitivity.

Inverse sensitivity = Deflection factor

$$\text{Deflection factor} = \frac{1}{\text{Sensitivity}} = \frac{\Delta q_i}{\Delta q_o}$$

The units of the sensitivity are millimeter per micro-ampere, millimeter per ohm, counts per volt, etc. while the units of a deflection factor are micro-ampere per millimeter, ohm per millimeter, volts per count, etc. The sensitivity of the instrument should be as high as possible and to achieve this range of an instrument should not greatly exceed the value to be measured.

Resolution:

It is the smallest increment of quantity being measured which can be detected with certainty by an instrument.

So if a nonzero input quantity is slowly increased, output reading will not increase until some minimum change in the input takes place. This minimum change which causes the change in the output is called resolution. The resolution of an instrument is also referred to as discrimination of the instrument. The resolution can affect the accuracy of the measurement.

Dynamic error:

It is the difference between the true value of the variable to be measured, changing with time and the value indicated by the measurement system, assuming zero static error.

The Fig. 1.13 shows the dead time, i.e. time delay and the dynamic error.

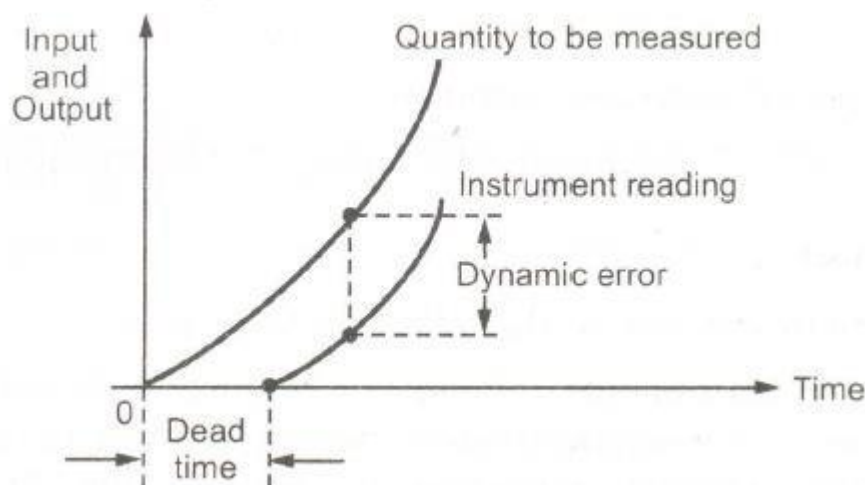
**Types of errors:**

The static error is defined earlier as the difference between the true value of the variable and the value indicated by the instrument. The static error may arise due to number of reasons. The static errors are classified as:

- 1) Gross errors
- 2) Systematic errors
- 3) Random errors

Gross errors:

The gross errors mainly occur due to carelessness or lack of experience of a human being. These cover human mistakes in readings, recordings and calculating results. These errors also occur due to incorrect adjustments of instruments. These errors cannot be treated mathematically. These errors are also called personal errors. Some gross errors are easily detected while others are very difficult to detect.

Systematic errors:

The systematic errors are mainly resulting due to the shortcomings of the instrument and the characteristics of the material used in the instrument, such as defective or worn parts, ageing effects, environmental effects, etc.

A constant uniform deviation of the operation of an instrument is known as a systematic error. There are three types of systematic errors as

- 1) Instrumental errors
- 2) Environmental errors
- 3) Observational errors

Random errors:

Some errors still result, though the systematic and instrumental errors are reduced or at least accounted for. The causes of such errors are unknown and hence, the errors are called **random** errors. These errors cannot be determined in the ordinary process of taking the measurements.

Absolute and relative errors:

When the error is specified in terms of an absolute quantity and not as a percentage, then it is called an absolute error.

Thus the voltage of 10 ± 0.5 V indicated ± 0.5 V as an absolute error. When the error is expressed as a percentage or as a fraction of the total quantity to be measured, then it is called relative error.

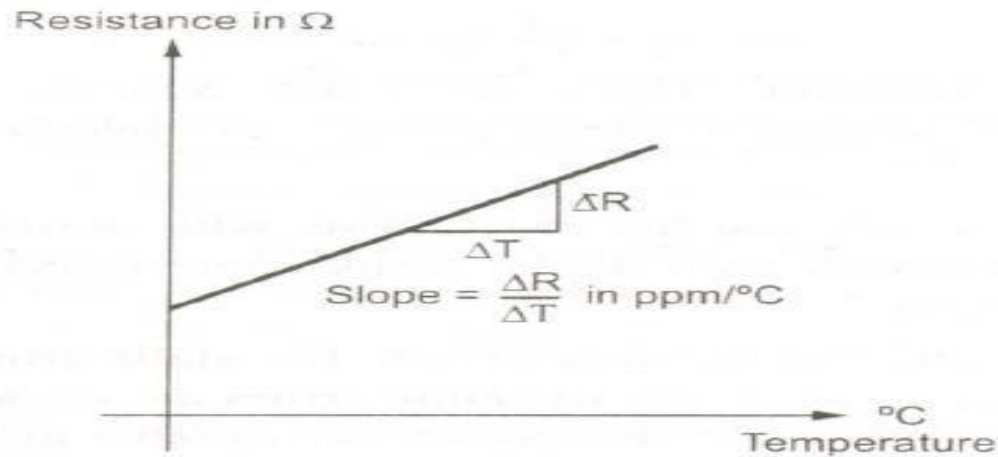

Generally the relative error in case of resistances is specified as percentage tolerances. Another method of expressing error is by specifying it as parts per million (ppm), relative to the total quantity. So it is a relative error specification. Generally change in resistance with temperature is indicated in ppm. °C shows the variation in resistance with Temperature temperature. Thus if a resistance of 100 kD. Has a temperature coefficient of 50 ppm/°C means 50 parts per millionth per degree celcius. Thus one millionth of 100 kohm. is 0.1 ohm and 50 such parts means 5 D. Th1-1s 1" change in temperature causes change of 5 D in 100 kohm. resistor.

Limiting errors:

The manufacturers specify the accuracy of the instruments within a certain percentage of full scale reading. The components like the resistor, inductor, capacitor are guaranteed to be within a certain percentage of rated value. This percentage indicates the deviations from the nominal or specified value of the particular quantity. These deviations from the specified value are called **Limiting Errors**. These are also called **Guarantee Errors**.

Thus the actual value with the limiting error can be expressed mathematically as,

$$A_a = A_s \pm \delta A$$

where

A_a = Actual value

A_s = Specified or rated value

δA = Limiting error or tolerance

This is also called fractional error. It is the ratio of the error to the specified magnitude of a quantity.

Thus
$$e = \frac{\delta A}{A_s}$$

where $e =$ Relative timing error

From the above equation, we can write,

$$\delta A = e \cdot A_s$$

and
$$A_a = A_s \pm \delta A$$

$$= A_s \pm e A_s$$

$$A_a = A_s [1 \pm e]$$

The percentage relative limiting error is expressed as

$$\% e = e \times 100$$

The relative limiting error can be also be expressed as,

$$e = \frac{\text{Actual value } (A_a) - \text{Specified value } (A_s)}{\text{Specified value } (A_s)}$$

Voltmeters and multimeters: Basic meter:

A basic d.c. meter uses a motoring principle for its operation. It states that any current carrying coil placed in a magnetic field experiences a force, which is proportional to the magnitude of current passing through the coil. This movement of coil is called D'Arsonval movement and basic meter is called D'Arsonvalgalvanometer.

D.C instruments:

- a) Using shunt resistance, d.c. current can be measured. The instrument is d.c. microammeter, milliammeter or ammeter.
- b) Using series resistance called multiplier, d.c. voltage can be measured. The instrument is d.c. millivoltmeter, voltmeter or kilovoltmeter.
- c) Using a battery and resistive network, resistance can be measured. The instrument is ohmmeter.

A.C instruments:

- a) Using a rectifier, a.c. voltages can be measured, at power and audio frequencies. The instrument is a.c. voltmeter.
- b) Using a thermocouple type meter radio frequency (RF) voltage or current can be measured.
- c) Using a thermistor in a resistive bridge network, expanded scale for power line voltage can be obtained.

Basic DC voltmeter:

The basic d.c. voltmeter is nothing but a permanent magnet moving coil (PMMC) or Arsonval galvanometer. The resistance is required to be connected in series with the basic meter to use it as a voltmeter. This series resistance is called a **multiplier**. The main function of the multiplier is to limit the current through the basic meter so that the meter current does not exceed the full scale deflection value. The voltmeter measures the voltage across the two points of a circuit or a voltage across a circuit component. The basic d.c. voltmeter is shown in the Fig.

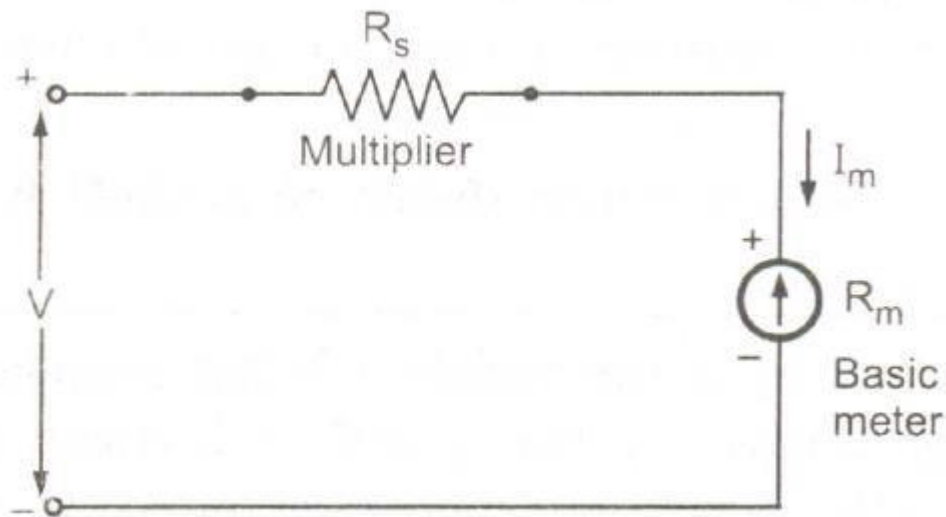

The voltmeter must be connected across the two points or a component, to measure the potential

The multiplier resistance can be calculated as:

Let R_m = internal resistance of coil i.e. meter

R_s = series multiplier resistance

I_m = full scale deflection current

V = full range voltage to be measured

From Fig. 2.1, $\therefore V = I_m (R_m + R_s)$

$$\therefore V = I_m R_m + I_m R_s$$

$$\therefore I_m R_s = V - I_m R_m$$

$$\therefore R_s = \frac{V}{I_m} - R_m$$

The multiplying factor for multiplier is the ratio of full range voltage to be measured and the drop across the basic meter.

Let v = drop across the basic meter = $I_m R_m$

$\therefore m$ = multiplying factor = $\frac{V}{v}$

$$= \frac{I_m (R_m + R_s)}{I_m R_m}$$

$$m = 1 + \frac{R_s}{R_m}$$

Hence multiplier resistance can also be expressed as,

$$R_s = (m - 1) R_m$$

Multirange voltmeters:

The range of the basic d.c. voltmeter can be extended by using number of multipliers and a selector switch. Such a meter is called **multirange voltmeter**

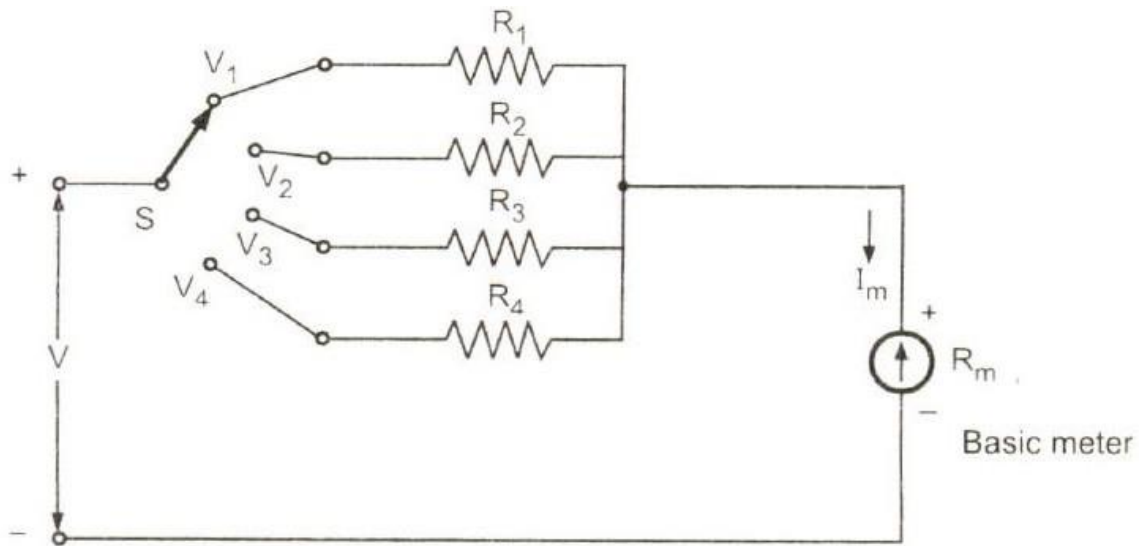

Multirange voltmeter

The \$R_1, R_2, R_3\$ and \$R_4\$ are the four series multipliers. When connected in series with the meter, they can give four different voltage ranges as \$V_1, V_2, V_3\$, and \$V_4\$. The selector switch \$S\$ is multiposition switch by which the required multiplier can be selected in the circuit.

The mathematical analysis of basic d.c. *voltmeter* is equally applicable for such multirange *voltmeter*. Thus,

$$R_1 = \frac{V_1}{I_m} - R_m \quad R_2 = \frac{V_2}{I_m} - R_m \quad \text{and so on.}$$

Sensitivity of voltmeters:

In a multirange voltmeter, the ratio of the total resistance R_r to the voltage range remains same. This ratio is nothing but the reciprocal of the full scale deflection current, of the meter i.e. $1/I_m$. This value is called sensitivity of the voltmeter. Thus the sensitivity of the voltmeter is defined ,

$$S = \frac{1}{\text{Full scale deflection current}}$$

$$S = \frac{1}{I_m} \Omega/V \text{ or } k\Omega/V$$

Loading effect:

While selecting a meter for a particular measurement, the sensitivity rating is very important. A low sensitive meter may give the accurate reading in low resistance circuit but will produce totally inaccurate reading in high resistance circuit.

The voltmeter is always connected across the two points between which the potential difference is to be measured. If it is connected across a low resistance then as voltmeter resistance is high, most of the current will pass through a low resistance and will produce the voltage drop which will be nothing but the true reading. But if the voltmeter is connected across the high resistance then due to two high resistances in parallel, the current will divide almost equally through the two paths. Thus the meter will record the voltage drop across the high resistance which will be much lower than the true reading. Thus the low sensitivity instrument when used in high resistance circuit gives a lower than the true reading. This is called loading effect of the voltmeters. It is mainly caused due to low sensitivity instruments.

A.C voltmeters using rectifier:

The PMMC movement used in d.c. voltmeters can be effectively used in a.c. voltmeters. The rectifier is used to convert a.c. voltage to be measured, to d.c. This d.c., if required is amplified and then given to the PMMC movement. The PMMC movement gives the deflection proportional to the quantity to

The r.m.s. value of an alternating quantity is given by that steady current (d.c.) which when flowing through a given circuit for a given time produces the same amount of heat as produced by the alternating current which when flowing through the same circuit for the same time. The r.m.s value is calculated by measuring the quantity at equal intervals for one complete cycle. Then squaring each quantity, the average of squared values is obtained. The square root of this average value is the r.m.s. value. The r.m.s means root-mean square i.e. squaring, finding the mean i.e. average and finally root.

If the waveform is continuous then instead of squaring and calculating mean, the integration is used. Mathematically the r.m.s. value of the continuous a.c. voltage having time period T is given by,

$$V_{\text{rms}} = \sqrt{\frac{1}{T} \int_0^T V_{\text{in}}^2 dt}$$

The $\frac{1}{T}$ term indicates the mean value or average value.

For purely sinusoidal quantity,

$$V_{\text{rms}} = 0.707 V_m$$

where $V_m =$ peak value of the sinusoidal quantity

If the a.c. quantity is continuous then average value can be expressed mathematically using an integration as,

$$V_{av} = \frac{2}{T} \int_0^{T/2} V_{in} dt$$

The interval $T/2$ indicates the average over half a cycle.

For purely sinusoidal quantity,

$$V_{av} = \frac{2}{\pi} V_m = 0.636 V_m$$

where $V_m =$ Peak value of the sinusoidal quantity.

The form factor is the ratio of r.m.s. value to the average value of an alternating quantity.

$$K_f = \frac{\text{r.m.s. value}}{\text{average value}} = \text{form factor}$$

Basic rectifier type voltmeter:

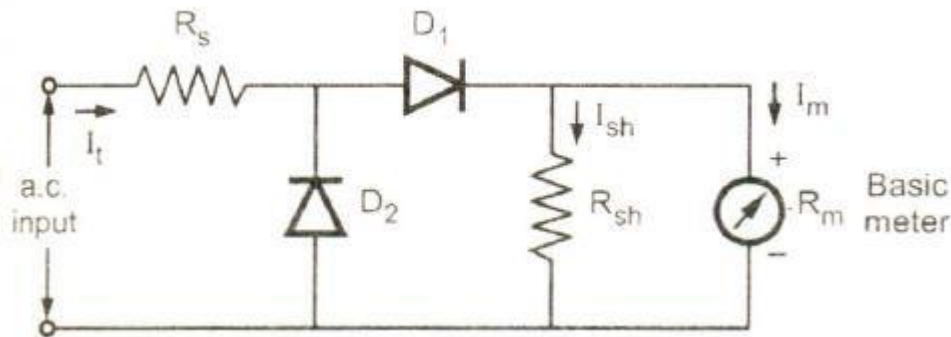

The diodes D_1 and D_2 are used for the rectifier circuit. The diodes show the nonlinear behaviour for the low currents hence to increase the current through diode D_1 , the meter is shunted with a resistance R_{sh} . This ensures high current through diode and its linear behaviour.

When the a.c. input is applied, for the positive half cycle, the diode D_1 conducts and causes the meter deflection proportional to the average value of that half cycle. In the negative cycle, the diode D_2 conducts and D_1 is reverse biased. The current through the meter is in opposite direction and hence meter movement is bypassed. Thus due to diodes, the rectifying action produces pulsating d.c. and

A.C voltmeter using fullwave rectifier:

The a.c. voltmeter using full wave rectifier is achieved by using bridge rectifier consisting of four diodes, as shown in the Fig

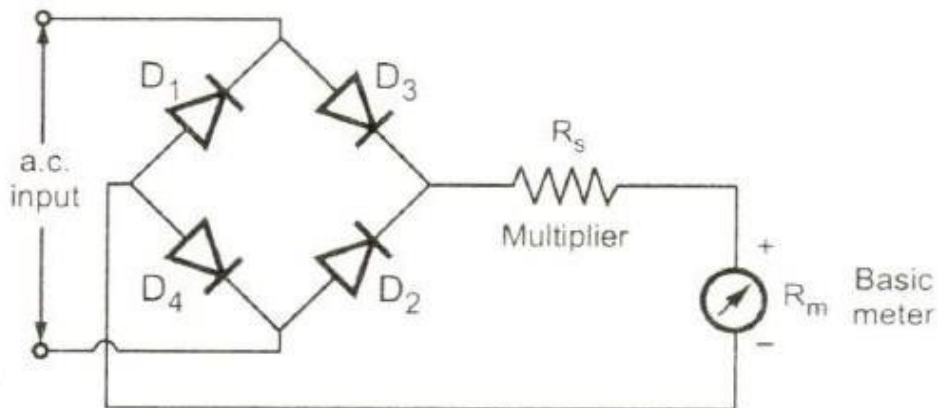
**Electronic multimeter:**

For the measurement of d.c. as well as a.c. voltage and current, resistance, an electronic multimeter is commonly used. It is also known as Voltage-Ohm Meter (VOM) or multimeter. The important salient features of YOM are as listed below.

- 1) The basic circuit of YOM includes balanced bridge d.c. amplifier.
- 2) To limit the magnitude of the input signal, RANGE switch is provided. By properly adjusting input attenuator input signal can be limited.
- 3) It also includes rectifier section which converts a.c. input signal to the d.c. voltage.
- 4) It facilitates resistance measurement with the help of internal battery and additional circuitry.
- 5) The various parameters measurement is possible by selecting required function using FUNCTION switch.
- 6) The measurement of various parameters is indicated with the help of indicating Meter.

Use of multimeter for D.C measurement:

For the measurement of d.c. as well as a.c. voltage and current, resistance, an electronic multimeter is commonly used. It is also known as Voltage-Ohm Meter (VOM) or multimeter. The important salient

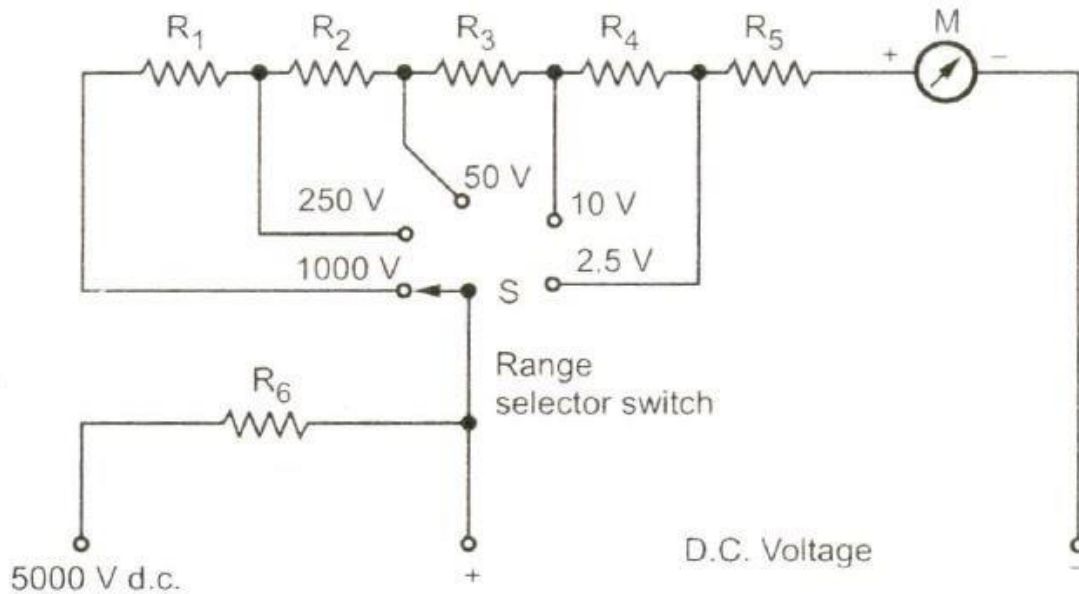

For getting different ranges of voltages, different series resistances are connected in series which can be put in the circuit with the range selector switch. We can get different ranges to measure the d.c. voltages by selecting the proper resistance in series with the basic meter.

Use of multimeter as ammeter:

To get different current ranges, different shunts are connected across the meter with the help of range selector switch. The working is same as that of PMMC ammeter

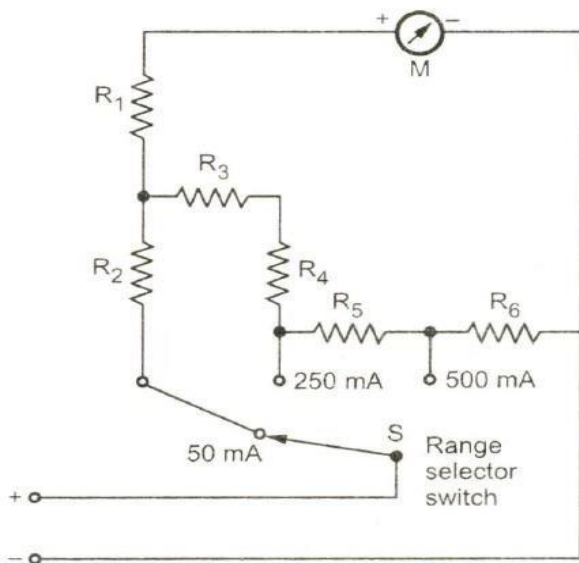

Use of multimeter for measurement of A.C voltage:

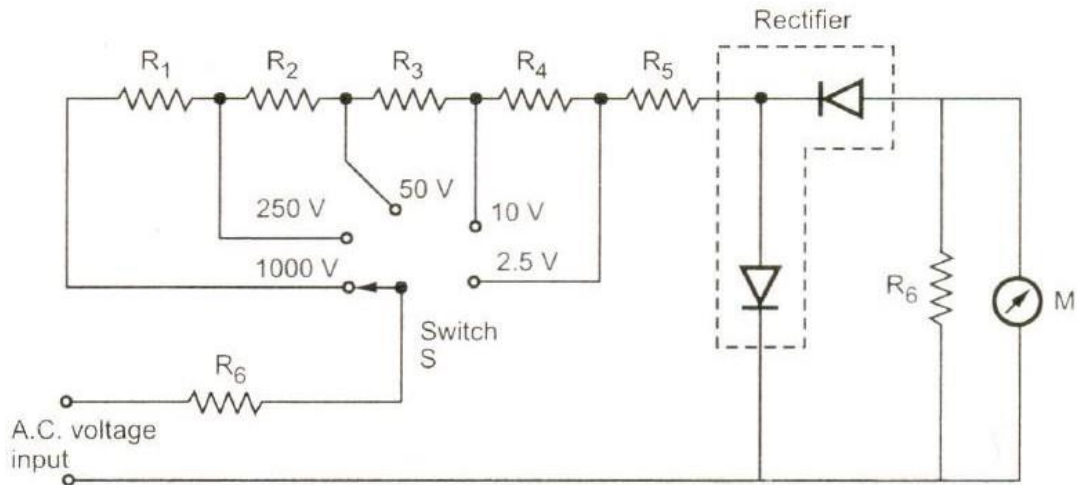

The rectifier used in the circuit rectifies a.c. voltage into d.c. voltage for measurement of a.c. voltage before current passes through the meter. The other diode is used for the protection purpose. **Use of multimeter for resistance measurement:**

The Fig shows ohmmeter section of multimeter for a scale multiplication of 1. Before any measurement is made, the instrument is short circuited and "zero adjust" control is varied until the meter reads zero resistance i.e. it shows full scale current. Now the circuit takes the form of a variation of the shunt type ohmmeter. Scale multiplications of 100 and 10,000 can also be used for measuring high resistances. Voltages are applied the circuit with the help of batte

