

UNIT 2
HIGHWAY GEOMETRIC DESIGN

UNIT 2

HIGHWAY GEOMETRIC DESIGN

Overview

The features of the cross-section of the pavement influence the life of the pavement as well as the riding comfort and safety. Of these, pavement surface characteristics affect both of these. Camber, kerbs, and geometry of various cross-sectional elements are important aspects to be considered in this regard. They are explained briefly in this chapter.

Pavement surface characteristics

For safe and comfortable driving four aspects of the pavement surface are important; the friction between the wheels and the pavement surface, smoothness of the road surface, the light reflection characteristics of the top of pavement surface, and drainage to water.

Friction

Friction between the wheel and the pavement surface is a crucial factor in the design of horizontal curves and thus the safe operating speed. Further, it also affects the acceleration and deceleration ability of vehicles. Lack of adequate friction can cause skidding or slipping of vehicles.

Skidding happens when the path traveled along the road surface is more than the circumferential movement of the wheels due to friction

Slip occurs when the wheel revolves more than the corresponding longitudinal movement along the road.

Various factors that affect friction are:

Type of the pavement (like bituminous, concrete, gravel), Condition of the pavement (dry or wet, hot or cold, etc), Condition of the tire (new or old), and Speed and load of the vehicle.

The frictional force that develops between the wheel and the pavement is the load acting multiplied by a factor called the coefficient of friction and denoted as f . The choice of the value of f is a very complicated issue since it depends on many variables. IRC suggests the coefficient of longitudinal friction as 0.35-0.4 depending on

the speed and coefficient of lateral friction as 0.15. The former is useful in sight distance calculation and the latter in horizontal curve design.

Unevenness

It is always desirable to have an even surface, but it is seldom possible to have such a one. Even if a road is constructed with high quality pavers, it is possible to develop unevenness due to pavement failures. Unevenness affect the vehicle operating cost, speed, riding comfort, safety, fuel consumption and wear and tear of tyres.

Unevenness index is a measure of unevenness which is the cumulative measure of vertical undulations of the pavement surface recorded per unit horizontal length of the road. An unevenness index value less than 1500 mm/km is considered as good, a value less than 2500 mm.km is satisfactory up to speed of 100 kmph and values greater than 3200 mm/km is considered as uncomfortable even for 55 kmph.

Light reflection

White roads have good visibility at night, but caused glare during day time. Black roads has no glare during day, but has poor visibility at night Concrete roads has better visibility and less glare

It is necessary that the road surface should be visible at night and reflection of light is the factor that answers it.

Drainage

The pavement surface should be absolutely impermeable to prevent seepage of water into the pavement layers. Further, both the geometry and texture of pavement surface should help in draining out the water from the surface in less time.

Camber

Camber or cant is the cross slope provided to raise middle of the road surface in the transverse direction to drain o rain water from road surface. The objectives of providing camber are:

Surface protection especially for gravel and bituminous roads Sub-grade protection by proper drainage quick drying of pavement which in turn increases safety

Too steep slope is undesirable for it will erode the surface. Camber is measured in 1 in n or n% (Eg. 1 in 50 or 2%) and the value depends on the type of pavement surface. The values suggested by IRC for various categories of pavement are given in Table 12:1. The common types of camber are parabolic, straight,

or combination of them (Figure 12:1)

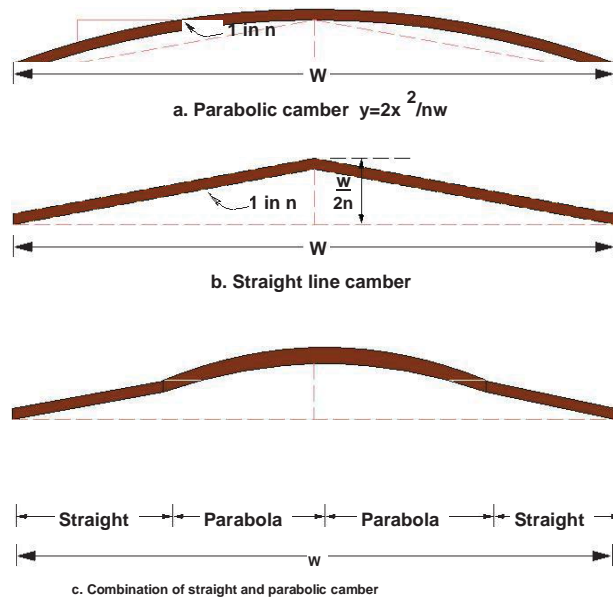

Figure 2:1: Different types of camber

Surface type	Heavy rain	Light rain
Concrete/Bituminous	2 %	1.7 %
Gravel/WBM	3 %	2.5 %
Earthen	4 %	3.0 %

Table 2:1: IRC Values for camber

Width of carriage way

Width of the carriage way or the width of the pavement depends on the width of the traffic lane and number of lanes. Width of a traffic lane depends on the width of the vehicle and the clearance. Side clearance improves operating speed and safety. The maximum permissible width of a vehicle is 2.44 and the desirable side clearance for single lane traffic is 0.68 m. This require minimum of lane width of 3.75 m for a single lane road (Table: 2.1a). However, the side clearance required is about 0.53 m, on either side or 1.06 m in the center. Therefore, a two lane road require minimum of 3.5 meter for each lane (Figure 12:2b). The desirable carriage way width recommended by IRC is given in Table 12:2

Table 2:1a: IRC Specification for carriage way width

Single lane	3.75
Two lane, no kerbs	7.0
Two lane, raised kerbs	7.5
Intermediate carriage	5.5
Multi-lane	3.5

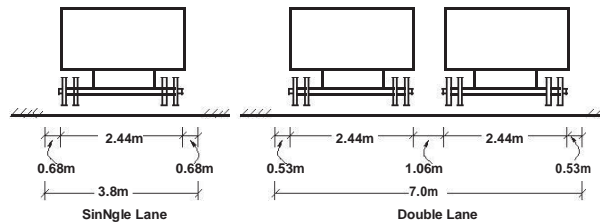

Figure 12:2: Lane width for single and two lane roads

Kerbs

Kerbs indicate the boundary between the carriage way and the shoulder or islands or footpaths.

Different types of kerbs are (Figure 12:3):

Low or mountable kerbs : This type of kerbs are provided such that they encourage the traffic to remain in the through traffic lanes and also allow the driver to enter the shoulder area with little difficulty. The height of this kerb is about 10 cm above the pavement edge with a slope which allows the vehicle to climb easily. This is usually provided at medians and channelization schemes and also helps in longitudinal drainage.

Semi-barrier type kerbs : When the pedestrian traffic is high, these kerbs are provided. Their height is 15 cm above the pavement edge. This type of kerb prevents encroachment of parking vehicles, but at acute emergency it is possible to drive over this kerb with some difficulty.

Barrier type kerbs: They are designed to discourage vehicles from leaving the pavement. They are provided when there is considerable amount of pedestrian traffic. They are placed at a height of 20 cm above the pavement edge with a steep batter.

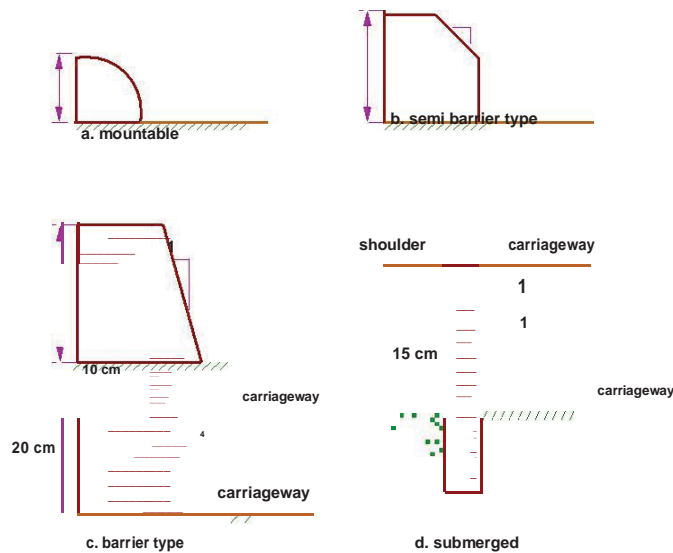

Figure 12:3: Different types of kerbs

Submerged kerbs : They are used in rural roads. The kerbs are provided at pavement edges between the pavement edge and shoulders. They provide lateral confinement and stability to the pavement.

Road margins

The portion of the road beyond the carriageway and on the roadway can be generally called road margin. Various elements that form the road margins are given below.

Shoulders

Shoulders are provided along the road edge and are intended for accommodation of stopped vehicles, serve as an emergency lane for vehicles and provide lateral support for base and surface courses. The shoulder should be strong enough to bear the weight of a fully loaded truck even in wet conditions. The shoulder width should be adequate for giving working space around a stopped vehicle. It is desirable to have a width of 4.6 m for the shoulders. A minimum width of 2.5 m is recommended for 2-lane rural highways in India.

Parking lanes

Parking lanes are provided in urban lanes for side parking. Parallel parking is preferred because it is safe for the vehicles moving on the road. The parking lane should have a minimum of 3.0 m width in the case of parallel parking.

Bus-bays

Bus bays are provided by recessing the kerbs for bus stops. They are provided so that they do not obstruct the movement of vehicles in the carriage way. They should be at least 75 meters away from the intersection so that the traffic near the intersections is not affected by the bus-bay.

Service roads

Service roads or frontage roads give access to access controlled highways like freeways and expressways. They run parallel to the highway and will be usually isolated by a separator and access to the highway will be provided only at selected points. These roads are provided to avoid congestion in the expressways and also the speed of the traffic in those lanes is not reduced.

Cycle track

Cycle tracks are provided in urban areas when the volume of cycle traffic is high. Minimum width of 2 meter is required, which may be increased by 1 meter for every additional track.

Footpath

Footpaths are exclusive right of way to pedestrians, especially in urban areas. They are provided for the safety of the pedestrians when both the pedestrian traffic and vehicular traffic is high. Minimum width is 1.5 meter and may be increased based on the traffic. The footpath should be either as smooth as the pavement or smoother than that to induce the pedestrian to use the footpath.

Guard rails

They are provided at the edge of the shoulder usually when the road is on an embankment. They serve to prevent the vehicles from running over the embankment, especially when the height exceeds 3 m. various designs of guard rails are there. Guard stones painted in alternate black and white are usually used. They also give better visibility of curves at night under headlights of vehicles.

Width of formation

Width of formation or roadway width is the sum of the widths of pavements or carriage way including separators and shoulders. This does not include the extra land in formation/cutting. The values suggested by IRC are given in Table 12:3.

Table 12:3: Width of formation for various classed of roads

Road classification	Roadway width in m	
	Plain and rolling terrain	Mountainous and steep terrain
NH/SH	12	6.25-8.8
MDR	9	4.75
ODR	7.5-9.0	4.75
VR	7.5	4.0

Right of way

Right of way (ROW) or land width is the width of land acquired for the road, along its alignment. It should be adequate to accommodate all the cross-sectional elements of the highway and may reasonably provide for future development. To prevent ribbon development along highways, control lines and building lines may be provided. Control line is a line which represents the nearest limits of future uncontrolled building activity in relation to a road. Building line represents a line on either side of the road; between which and the road no building activity is permitted at all. The right of way width is governed by:

Width of formation: It depends on the category of the highway and width of roadway and road margins. Height of embankment or depth of cutting: It is governed by the topography and the vertical alignment. Side slopes of embankment or cutting: It depends on the height of the slope, soil type etc.

Drainage system and their size which depends on rainfall, topography etc.

Sight distance considerations: On curves etc. there is restriction to the visibility on the inner side of the curve due to the presence of some obstructions like building structures etc.

Reserve land for future widening: Some land has to be acquired in advance anticipating future developments like widening of the road.

Table 12:4: Normal right of way for open areas

Road classification	Roadway width in m	
	Plain and rolling terrain	Mountainous and steep terrain
Open areas		
NH/SH	45	24
MDR	25	18
ODR	15	15
VR	12	9
Built-up areas		
NH/SH	30	20
MDR	20	15
ODR	15	12
VR	10	9

The importance of reserved land is emphasized by the following. Extra width of land is available for the construction of roadside facilities. Land acquisition is not possible later, because the land may be occupied for various other purposes (buildings, business etc.) The normal ROW requirements for built up and open areas as specified by IRC is given in Table 12:4

Sight distance

Overview

The safe and efficient operation of vehicles on the road depends very much on the visibility of the road ahead of the driver. Thus the geometric design of the road should be done such that any obstruction on the road length could be visible to the driver from some distance ahead. This distance is said to be the sight distance.

Types of sight distance

Sight distance available from a point is the actual distance along the road surface, over which a driver from a specified height above the carriage way has visibility of stationary or moving objects.

Three sight distance situations are considered for design:

Stopping sight distance (SSD) or the absolute minimum sight distance

Intermediate sight distance (ISD) is defined as twice SSD

Overtaking sight distance (OSD) for safe overtaking operation

Head light sight distance is the distance visible to a driver during night driving under the illumination of head lights

Safe sight distance to enter into an intersection.

The most important consideration in all these is that at all times the driver traveling at the design speed of the highway must have sufficient carriageway distance within his line of vision to allow him to stop his vehicle before colliding with a slowly moving or stationary object appearing suddenly in his own traffic lane.

The computation of sight distance depends on:

Reaction time of the driver

Reaction time of a driver is the time taken from the instant the object is visible to the driver to the instant when the brakes are applied. The total reaction time may be split up into four components based on PIEV theory. In practice, all these times are usually combined into a total perception-reaction time suitable for design purposes as well as for easy measurement. Many of the studies show that drivers require about 1.5 to 2 secs under normal conditions. However, taking into consideration the variability of driver characteristics, a higher value is normally used in design. For example, IRC suggests a reaction time of 2.5 secs. Speed of the vehicle

The speed of the vehicle very much affects the sight distance. Higher the speed, more time will be required to stop the vehicle. Hence it is evident that, as the speed increases, sight distance also increases.

Efficiency of brakes

The efficiency of the brakes depends upon the age of the vehicle, vehicle characteristics etc. If the brake efficiency is 100%, the vehicle will stop the moment the brakes are applied. But practically, it is not possible to achieve 100% brake efficiency. Therefore the sight distance required will be more when the efficiency of brakes are less. Also for safe geometric design, we assume that the vehicles have only 50% brake efficiency.

Frictional resistance between the tyre and the road

The frictional resistance between the tyre and road plays an important role to bring the vehicle to stop. When the frictional resistance is more, the vehicles stop immediately. Thus sight required will be less. No separate provision for brake efficiency is provided while computing the sight distance. This is taken into account along with the factor of longitudinal friction. IRC has specified the value of longitudinal friction in between 0.35 to 0.4.

Gradient of the road.

Gradient of the road also affects the sight distance. While climbing up a gradient, the vehicle can stop immediately. Therefore sight distance required is less. While descending a gradient, gravity also comes into action and more time will be required to stop the vehicle. Sight distance required will be more in this case.

Stopping sight distance

Stopping sight distance (SSD) is the minimum sight distance available on a highway at any spot having sufficient length to enable the driver to stop a vehicle traveling at design speed, safely without collision with any other obstruction.

There is a term called safe stopping distance and is one of the important measures in traffic engineering. It is the distance a vehicle travels from the point at which a situation is first perceived to the time the deceleration is complete. Drivers must have adequate time if they are to suddenly respond to a situation. Thus in highway design, sight distance at least equal to the safe stopping distance should be provided. The stopping sight distance is the sum of lag distance and the braking distance. Lag distance is the distance the vehicle traveled during the reaction time t and is given by vt , where v is the velocity in m/sec . Braking distance is the distance traveled by the vehicle during braking operation. For a level road this is obtained by equating the work done in stopping the vehicle and the kinetic energy of the vehicle. If F is the maximum frictional force developed and the braking distance is l , then work done against friction in stopping the vehicle is $F l = f W l$ where W is the total weight of the vehicle. The kinetic energy at the design speed is

$$\frac{1}{2}mv^2 = \frac{1}{2} \frac{Wv^2}{g}$$
$$f W l = \frac{Wv^2}{2g}$$

Therefore, the SSD = lag distance + braking distance and given by:

$$SSD = vt + \frac{v^2}{2gf} \quad (13.1)$$

Where v is the design speed in m/sec , t is the reaction time in sec, g is the acceleration due to gravity and f is the coefficient of friction. The coefficient of friction f is given below for various design speed. When there is an

Table 13:1: Coefficient of longitudinal friction

Speed, kmph	<30	40	50	60	>80
f	0.40	0.38	0.37	0.36	0.35

Ascending gradient of say +n%, the component of gravity adds to braking action and hence braking distance is decreased. The component of gravity acting parallel to the surface which adds to the the braking force is equal to $W \sin N$ $W \tan N = W n=100$. Equating kinetic energy and work done:

$$f W + \frac{W n}{100} l = \frac{W v^2}{2g}$$

$$l = \frac{v^2}{2g f + \frac{n}{100}}$$

Similarly the braking distance can be derived for a descending gradient. Therefore the general equation is given by Equation 13.2.

$$SSD = vt + \frac{v^2}{2g(f - 0.01n)} \tag{13.2}$$

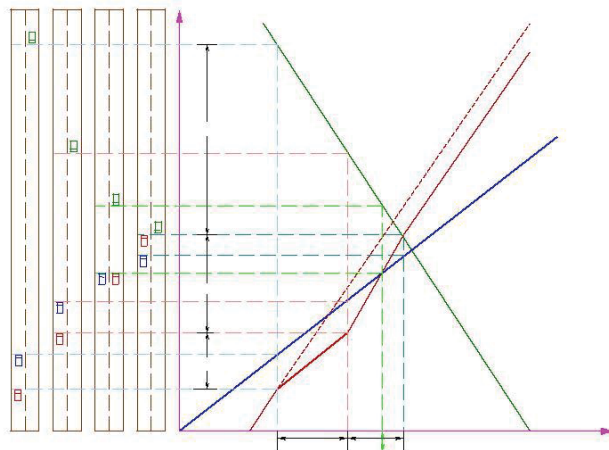

Figure 13:1: Time-space diagram: Illustration of overtaking sight distance

Overtaking sight distance

The overtaking sight distance is the minimum distance open to the vision of the driver of a vehicle intending to overtake the slow vehicle ahead safely against the traffic in the opposite direction. The overtaking sight distance or passing sight distance is measured along the center line of the road over which a driver with his eye level 1.2 m above the road surface can see the top of an object 1.2 m above the road surface.

The factors that affect the OSD are:

Velocities of the overtaking vehicle, overtaken vehicle and that of the vehicle coming in the opposite direction.

Spacing between vehicles, which in-turn depends on the speed

Skill and reaction time of the driver

Rate of acceleration of overtaking vehicle

Gradient of the road

The dynamics of the overtaking operation is given in the figure which is a time-space diagram. The x-axis denotes the time and y-axis shows the distance traveled by the vehicles. The trajectory of the slow moving vehicle (B) is shown as a straight line which indicates that it is traveling at a constant speed. A fast moving vehicle (A) is traveling behind the vehicle B. The trajectory of the vehicle is shown initially with a steeper slope. The dotted line indicates the path of the vehicle A if B was absent. The vehicle A slows down to follow the vehicle B as shown in the figure with same slope from t_0 to t_1 . Then it overtakes the vehicle B and occupies the left lane at time t_3 . The time duration $T = t_3 - t_1$ is the actual duration of the overtaking operation. The snapshots of the road at time t_0 ; t_1 , and t_3 are shown on the left side of the figure. From the Figure 13:1, the overtaking sight distance consists of three parts.

d_1 is the distance traveled by overtaking vehicle A during the reaction time $t = t_1 - t_0$

d_2 is the distance traveled by the vehicle during the actual overtaking operation $T = t_3 - t_1$

d_3 is the distance traveled by on-coming vehicle C during the overtaking operation (T).

Therefore:

$$\text{OSD} = d_1 + d_2 + d_3 \quad (13.3)$$

It is assumed that the vehicle A is forced to reduce its speed to v_b , the speed of the slow moving vehicle B and travels behind it during the reaction time t of the driver. So d_1 is given by:

$$d_1 = v_b t \quad (13.4)$$

Then the vehicle A starts to accelerate, shifts the lane, overtake and shift back to the original lane. The vehicle A maintains the spacing s before and after overtaking. The spacing s in m is given by:

$$s = 0.7v_b + 6 \quad (13.5)$$

Let T be the duration of actual overtaking. The distance traveled by B during the overtaking operation is $2s + v_b T$. Also, during this time, vehicle A accelerated from initial velocity v_b and overtaking is completed while reaching velocity v . Hence the distance traveled is given by:

$$\begin{aligned}
 d_2 &= v_b T + \frac{1}{2} a T^2 \\
 2s + v_b T &= v_b T + \frac{1}{2} a T^2 \\
 2s &= \frac{1}{2} a T^2 \\
 T &= r \frac{4s}{a} \\
 d^2 &= 2s + v_b \frac{4s}{a} \tag{13.6}
 \end{aligned}$$

The distance traveled by the vehicle C moving at design speed v m=sec during overtaking operation is given by:

$$d_3 = vT \tag{13.7}$$

The overtaking sight distance is (Figure 13:1)

$$OSD = v_b t + 2s + v_b \frac{4s}{a} + vT \tag{13.8}$$

Where v_b is the velocity of the slow moving vehicle in m=sec², t the reaction time of the driver in sec, s is the spacing between the two vehicle in m given by equation 13.5 and a is the overtaking vehicles acceleration in m=sec². In case the speed of the overtaken vehicle is not given, it can be assumed that it moves 16 kmph slower the the design speed.

The acceleration values of the fast vehicle depends on its speed and given in Table 13:2. Note that:

Table 13:2: Maximum overtaking acceleration at different speeds

Speed (kmph)	Maximum overtaking acceleration (m/sec ²)
25	1.41
30	1.30
40	1.24
50	1.11
65	0.92
80	0.72
100	0.53

On divided highways, d_3 need not be considered

On divided highways with four or more lanes, IRC suggests that it is not necessary to provide the OSD, but only SSD is sufficient.

Overtaking zones

Overtaking zones are provided when OSD cannot be provided throughout the length of the highway. These are zones dedicated for overtaking operation, marked with wide roads. The desirable length of overtaking zones is 5 time OSD and the minimum is three times OSD (Figure 13:2).

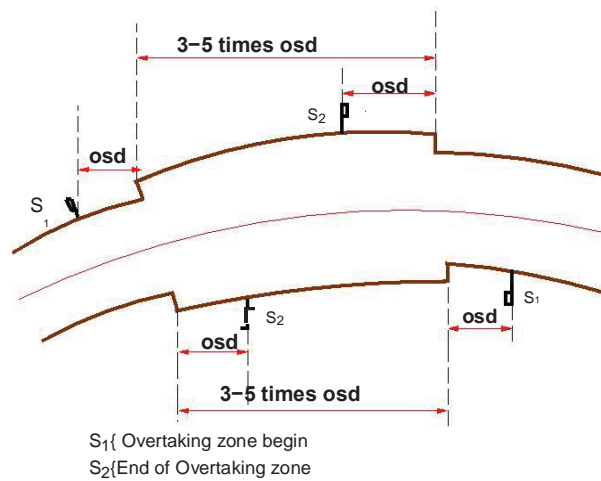

Figure 13:2: Overtaking zones

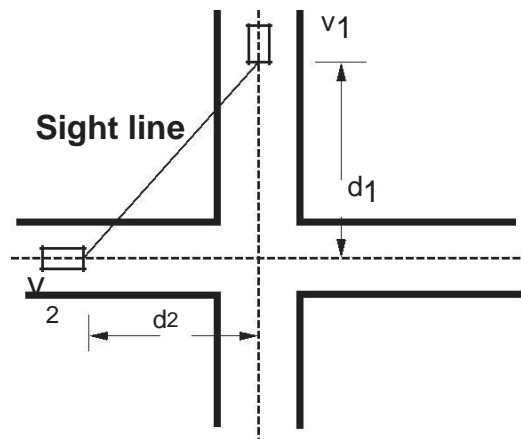

Figure 13:3: Sight distance at intersections

Sight distance at intersections

At intersections where two or more roads meet, visibility should be provided for the drivers approaching the intersection from either side. They should be able to perceive a hazard and stop the vehicle if required. Stopping sight distance for each road can be computed from the design speed. The sight distance should be provided such that the drivers on either side should be able to see each other. This is illustrated in the figure 13:3.

Design of sight distance at intersections may be used on three possible conditions:

Enabling approaching vehicle to change the speed

Enabling approaching vehicle to stop

Enabling stopped vehicle to cross a main road

Horizontal alignment

Design Speed

The design speed, as noted earlier, is the single most important factor in the design of horizontal alignment. The design speed also depends on the type of the road. For e.g., the design speed expected from a National highway will be much higher than a village road, and hence the curve geometry will vary significantly.

The design speed also depends on the type of terrain. A plain terrain can have any geometry, but for the same standard in a hilly terrain requires substantial cutting and filling implying exorbitant costs as well as safety concern due to unstable slopes. Therefore, the design speed is normally reduced for terrains with steep slopes.

For instance, Indian Road Congress (IRC) has classified the terrains into four categories, namely plain, rolling, mountainous, and steep based on the cross slope as given in table 14:1. Based on the type of road and type of terrain the design speed varies. The IRC has suggested desirable or ruling speed as well as minimum suggested design speed and is tabulated in table 14:2. The recommended design speed is given in Table 14:2.

Table 14:1: Terrain classification

Terrain classification	Cross slope (%)
Plain	0-10
Rolling	10-25
Mountainous	25-60
Steep	> 60

Table 14:2: Design speed in km=hr as per IRC (ruling and minimum

Type	Plain	Rolling	Hilly	Steep
NS&SH	100-80	80-65	50-40	40-30
MDR	80-65	65-50	40-30	30-20
ODR	65-50	50-40	30-25	25-20
VR	50-40	40-35	25-20	25-20

Horizontal curve

The presence of horizontal curve imparts centrifugal force which is reactive force acting outward on a vehicle negotiating it. Centrifugal force depends on speed and radius of the horizontal curve and is counteracted to a certain extent by transverse friction between the tyre and pavement surface. On a curved road, this force tends to cause the vehicle to overrun or to slide outward from the centre of road curvature. For proper design of the curve, an understanding of the forces acting on a vehicle taking a horizontal curve is necessary. Various forces acting on the vehicle are illustrated in the figure 14:1.

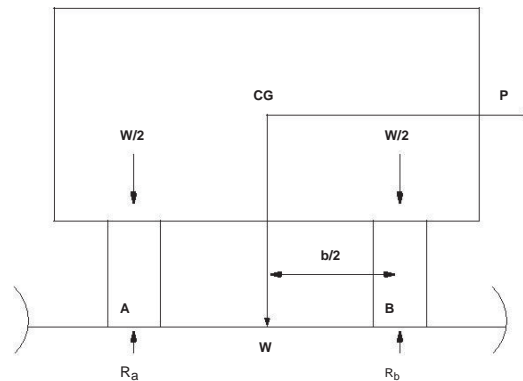

Figure 14:1: Effect of horizontal curve

They are the centrifugal force (P) acting outward, weight of the vehicle (W) acting downward, and the reaction of the ground on the wheels (R_A and R_B). The centrifugal force and the weight is assumed to be from the centre of gravity which is at h units above the ground. Let the wheel base be assumed as b units. The centrifugal force P in $\text{kg}=\text{m}^2$ is given by

$$P = \frac{W v^2}{gR} \quad (14.1)$$

where W is the weight of the vehicle in kg , v is the speed of the vehicle in $\text{m}=\text{sec}$, g is the acceleration due to gravity in $\text{m}=\text{sec}^2$ and R is the radius of the curve in m .

The centrifugal ratio or the impact factor $\frac{P}{W}$ is given by:

$$\frac{P}{W} = \frac{v^2}{gR} \quad (14.2)$$

The centrifugal force has two effects: A tendency to overturn the vehicle about the outer wheels and a tendency for transverse skidding. Taking moments of the forces with respect to the outer wheel when the vehicle is just

about to override,

$$P h = W \frac{b}{2} \quad \text{or} \quad \frac{P}{W} = \frac{b}{2h}$$

At the equilibrium over turning is possible when

$$\frac{v^2}{gR} = \frac{b}{2h}$$

and for safety the following condition must satisfy:

$$\frac{b}{2h} > \frac{v^2}{gR} \quad (14.3)$$

The second tendency of the vehicle is for transverse skidding. i.e. When the centrifugal force P is greater than the maximum possible transverse skid resistance due to friction between the pavement surface and tyre. The transverse skid resistance (F) is given by:

$$F = \frac{F_A + F_B}{f(R_A + R_B)} = fW$$

where F_A and F_B is the fractional force at tyre A and B, R_A and R_B is the reaction at tyre A and B, f is the lateral coefficient of friction and W is the weight of the vehicle. This is counteracted by the centrifugal force (P), and equating:

$$P = fW$$

At equilibrium, when skidding takes place (from equation 14.2)

$$\frac{P}{W} = f = \frac{v^2}{gR}$$

and for safety the following condition must satisfy:

$$f > \frac{v^2}{gR} \quad (14.4)$$

Equation 14.3 and 14.4 give the stable condition for design. If equation 14.3 is violated, the vehicle will overturn at the horizontal curve and if equation 14.4 is violated, the vehicle will skid at the horizontal curve

Analysis of super-elevation

Super-elevation or cant or banking is the transverse slope provided at horizontal curve to counteract the centrifugal force, by raising the outer edge of the pavement with respect to the inner edge, throughout the length of the horizontal curve. When the outer edge is raised, a component of the curve weight will be complimented in counteracting the effect of centrifugal force. In order to and out how much this raising should be, the following analysis may be done. The forces acting on a vehicle while taking a horizontal curve with super elevation is shown in figure 14:2.

Forces acting on a vehicle on horizontal curve of radius R m at a speed of v m/sec² are:

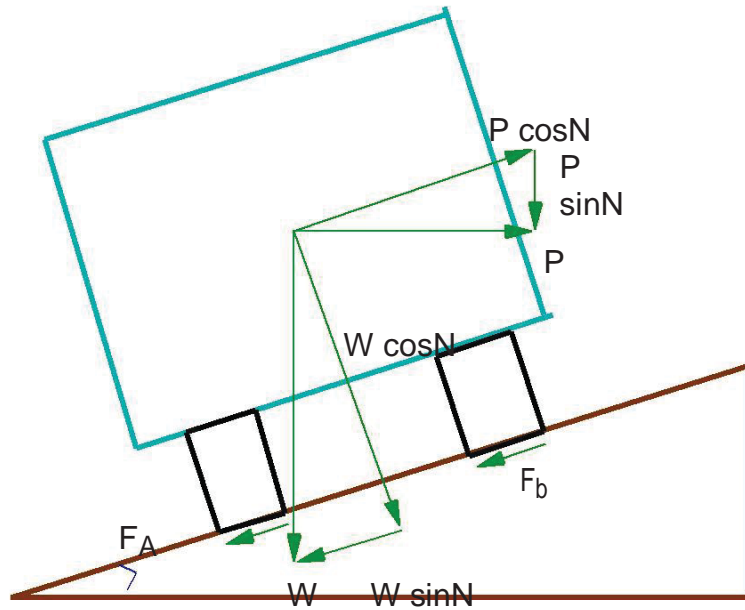

Figure 14:2: Analysis of super-elevation

P the centrifugal force acting horizontally out-wards through the center of gravity,

W is the weight of the vehicle acting down-wards through the center of gravity,

F is the friction force between the wheels and the pavement, along the surface inward.

At equilibrium, by resolving the forces parallel to the surface of the pavement we get,

$$P \sin N = W \sin N + F_A + F_B$$

$$P \sin N = W \sin N + f (R_A + R_B)$$

$$P \sin N = W \sin N + f (W \cos N + P \sin N)$$

where W is the weight of the vehicle, P is the centrifugal force, f is the coefficient of friction, N is the transverse slope due to super elevation. Dividing by $W \cos N$, we get:

$$\frac{P}{W} = \frac{v^2}{gR} = 1 - f \tan N$$
(14.6)

This is an exact expression for super elevation. But normally, $f = 0.15$ and $\theta < 4^\circ$, $1 - f \tan \theta \approx 1$ and for small θ , $\tan \theta \approx \sin \theta = \frac{E}{B} = e$, then equation 14.6 becomes:

$$e + f = \frac{v^2}{gR} \quad (14.7)$$

Where, e is the rate of super elevation, f the coefficient of lateral friction 0.15 , v the speed of the vehicle in m/sec , R the radius of the curve in m and $g = 9.8 \text{ m/sec}^2$.

Three specific cases that can arise from equation 14.7 are as follows:

If there is no friction due to some practical reasons, then $f = 0$ and equation 14.7 becomes

$$e = \frac{v^2}{gR}$$

This results in the situation where the pressure on the outer and inner wheels are same; requiring very high super-elevation e .

12.4 If there is no super-elevation provided due to some practical reasons, then $e = 0$ and equation 14.7 becomes

12.5 $f = \frac{v^2}{gR}$ This results in a very high coefficient of friction.

3 If $e = 0$ and $f = 0.15$ then for safe traveling speed from equation 14.7 is given by $v_b = \sqrt{gR(f + e)}$ where v_b is the restricted speed.

Design of super-elevation

For fast moving vehicles, providing higher super elevation without considering coefficient of friction is safe, i.e. centrifugal force is fully counteracted by the weight of the vehicle or super elevation. For slow moving vehicles, providing lower super elevation considering coefficient of friction is safe, i.e. centrifugal force is counteracted by super elevation and coefficient of friction. IRC suggests following design procedure:

Step 1 Find e for 75 percent of design speed, neglecting f , i.e. $e_1 = \frac{(0.75v)^2}{gR}$.

Step 2 If $e_1 \leq 0.07$, then $e = e_1 = \frac{(0.75v)^2}{gR}$, else if $e_1 > 0.07$ go to step 3.

Step 3 Find f_1 for the design speed and max e , i.e. $f_1 = \frac{v^2}{gR} - e = \frac{v^2}{gR} - 0.07$. If $f_1 \leq 0.15$, then the maximum $e = 0.07$ is safe for the design speed, else go to step 4.

Step 4 Find the allowable speed v_a for the maximum $e = 0.07$ and $f = 0.15$, $v_a = \sqrt{gR(0.22)}$ If $v_a > v$ then the design is adequate, otherwise use speed adopt control measures or look for speed control measures.

Maximum and minimum super-elevation

Depends on

- (a) Slow moving vehicle and
- (b) Heavy loaded trucks with high CG.

IRC specifies a maximum super-elevation of 7 percent for plain and rolling terrain, while that of hilly terrain is 10 percent and urban road is 4 percent. The minimum super elevation is 2-4 percent for drainage purpose, especially for large radius of the horizontal curve.

Attainment of super-elevation

- Elimination of the crown of the cambered section by:
 - Rotating the outer edge about the crown: The outer half of the cross slope is rotated about the crown at a desired rate such that this surface falls on the same plane as the inner half.
 - Shifting the position of the crown: This method is also known as diagonal crown method. Here the position of the crown is progressively shifted outwards, thus increasing the width of the inner half of cross section progressively.
- Rotation of the pavement cross section to attain full super elevation by: There are two methods of attaining super elevation by rotating the pavement
 - Rotation about the center line : The pavement is rotated such that the inner edge is depressed and the outer edge is raised both by half the total amount of super elevation, i.e., by $E=2$ with respect to the centre.
 - Rotation about the inner edge: Here the pavement is rotated raising the outer edge as well as the centre such that the outer edge is raised by the full amount of super elevation with respect to the inner edge.

Radius of Horizontal Curve

The radius of the horizontal curve is an important design aspect of the geometric design. The maximum comfortable speed on a horizontal curve depends on the radius of the curve. Although it is possible to design the curve with maximum super elevation and coefficient of friction, it is not desirable because re-alignment would be required if the design speed is increased in future. Therefore, a ruling minimum radius R_{ruling} can be derived by assuming maximum super elevation and coefficient of friction.

$$R_{\text{ruling}} = \frac{v^2}{g(e + f)} \quad (15.1)$$

Ideally, the radius of the curve should be higher than R_{ruling} . However, very large curves are also not desirable. Setting out large curves in the field becomes difficult. In addition, it also enhances driving strain.

Extra widening

Extra widening refers to the additional width of carriageway that is required on a curved section of a road over and above that required on a straight alignment. This widening is done due to two reasons: the first and most important is the additional width required for a vehicle taking a horizontal curve and the second is due to the tendency of the drivers to ply away from the edge of the carriageway as they drive on a curve. The first is referred as the mechanical widening and the second is called the psychological widening. These are discussed in detail below. Tendency of the drivers to ply away from the edge of the carriageway as they drive on a curve. The first is referred as the mechanical widening and the second is called the psychological widening. These are discussed in detail below.

Mechanical widening

The reasons for the mechanical widening are: When a vehicle negotiates a horizontal curve, the rear wheels follow a path of shorter radius than the front wheels as shown in figure 15.5. This phenomenon is called o - tracking, and has the effect of increasing the effective width of a road space required by the vehicle. Therefore, to provide the same clearance between vehicles traveling in opposite direction on curved roads as is provided on straight sections, there must be extra width of carriageway available. This is an important factor when high proportion of vehicles are using the road. Trailer trucks also need extra carriageway, depending on the type of joint. In addition speeds higher than the design speed causes transverse skidding which requires additional width for safety purpose. The expression for extra width can be derived from the simple geometry of a vehicle at a horizontal curve as shown in figure 15.5. Let R_1 is the radius of the outer track line of the rear wheel, R_2 is the radius of the outer track line of the front wheel l is the distance between the front and rear wheel, n is the number of lanes, then the mechanical widening W_m (refer gure 15:1) is derived below:

$$\begin{aligned}
 R_2^2 &= R_1^2 + l^2 \\
 &= (R_2 - W_m)^2 + l^2 \\
 &= R_2^2 - 2R_2W_m + W_m^2 + l^2 \\
 2R_2W_m - W_m^2 &= l^2
 \end{aligned}$$

Therefore the widening needed for a single lane road is:

$$W_m = \frac{l^2}{2R_2} \quad (15.2)$$

If the road has n lanes, the extra widening should be provided on each lane. Therefore, the extra widening of a road with n lanes is given by,

$$W_m = \frac{nl^2}{2R} \quad (15.3)$$

Please note that for large radius, $R_2 \approx R$, which is the mean radius of the curve, then W_m is given by:

$$W_m = \frac{nl^2}{2R} \quad (15.4)$$

15.4. Psychological widening

Widening of pavements has to be done for some psychological reasons also. There is a tendency for the drivers to drive close to the edges of the pavement on curves. Some extra space is to be provided for more clearance for the crossing and overtaking operations on curves. IRC proposed an empirical relation for the psychological

widening at horizontal curves W_{ps} :

$$W_{ps} = \frac{v}{2.64P\sqrt{R}} \quad (15.5)$$

Therefore, the total widening needed at a horizontal curve W_e is:

$$\begin{aligned} W_e &= W_m + W_{ps} \\ &= \frac{nl^2}{2R} + \frac{v}{2.64 R} \end{aligned} \quad (15.6)$$

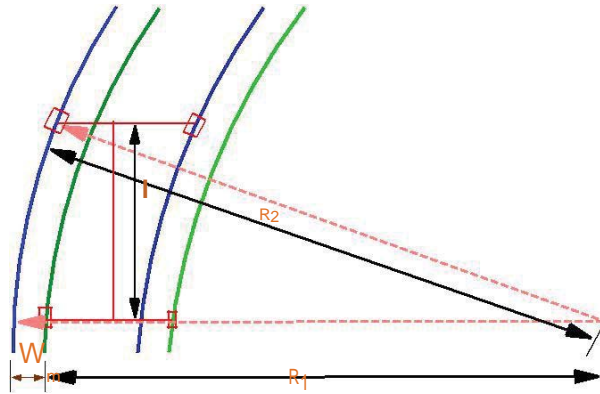

Figure 15:1: Extra-widening at a horizontal curve

Horizontal Transition Curves

Transition curve is provided to change the horizontal alignment from straight to circular curve gradually and has a radius which decreases from infinity at the straight end (tangent point) to the desired radius of the circular curve at the other end (curve point) There are five objectives for providing transition curve and are given below:

- ❖ To introduce gradually the centrifugal force between the tangent point and the beginning of the circular curve, avoiding sudden jerk on the vehicle. This increases the comfort of passengers.
- ❖ To enable the driver turn the steering gradually for his own comfort and security,
- ❖ To provide gradual introduction of super elevation, and
- ❖ To provide gradual introduction of extra widening.
- ❖ To enhance the aesthetic appearance of the road. Type of transition curve

Different types of transition curves are spiral or clothoid, cubic parabola, and Lemniscate. IRC recommends spiral as the transition curve because:

it fulfills the requirement of an ideal transition curve, that is;

rate of change of centrifugal acceleration is consistent (smooth) and

radius of the transition curve is ∞ at the straight edge and changes to R at the curve point (L_s / R^1) and calculation and field implementation is very easy.

Length of transition curve

The length of the transition curve should be determined as the maximum of the following three criteria: rate of change of centrifugal acceleration, rate of change of super elevation, and an empirical formula given by IRC.

1. Rate of change of centrifugal acceleration

At the tangent point, radius is infinity and hence centrifugal acceleration is zero. At the end of the transition, the radius R has minimum value R. The rate of change of centrifugal acceleration should be adopted such that the design should not cause discomfort to the drivers. If c is the rate of change of centrifugal acceleration, it can be written as:

$$\begin{aligned} c &= \frac{v_R^2}{t} ; \\ &= \frac{v^2}{L_s} ; \\ &= \frac{v^3}{L_s R} ; \end{aligned}$$

Therefore, the length of the transition curve L_{s1} in m is

$$L_{s1} = \frac{v^3}{cR} ; \quad (16.1)$$

where c is the rate of change of centrifugal acceleration given by an empirical formula suggested by IRC as below:

$$\text{subject to :} \quad c = \frac{80}{75 + 3.6v} ; \quad (16.2)$$

$$c_{min} = 0.5;$$

$$c_{max} = 0.8;$$

2. Rate of introduction of super-elevation

Raise (E) of the outer edge with respect to inner edge is given by $E = eB = e(W + W_e)$. The rate of change

of this raise from 0 to E is achieved gradually with a gradient of 1 in N over the length of the transition curve (typical range of N is 60-150). Therefore, the length of the transition curve L_{S2} is:

$$L_{S2} = N e(W + W_e) \quad (16.3)$$

3. By empirical formula

IRC suggest the length of the transition curve is minimum for a plain and rolling terrain:

$$L_{s3} = \frac{35v^2}{R} \quad (16.4)$$

and for steep and hilly terrain is:

$$L_{s3} = \frac{12.96v^2}{R} \quad (16.5)$$

and the shift s as:

$$s = \frac{L_s^2}{24R} \quad (16.6)$$

The length of the transition curve L_S is the maximum of equations 16.1, 16.3 and 16.4or16.5, i.e.

$$L_S = \text{Max} : (L_{S1} ; L_{S2} ; L_{S3}) \quad (16.7)$$

Setback Distance

Setback distance m or the clearance distance is the distance required from the centerline of a horizontal curve to an obstruction on the inner side of the curve to provide adequate sight distance at a horizontal curve. The setback distance depends on:

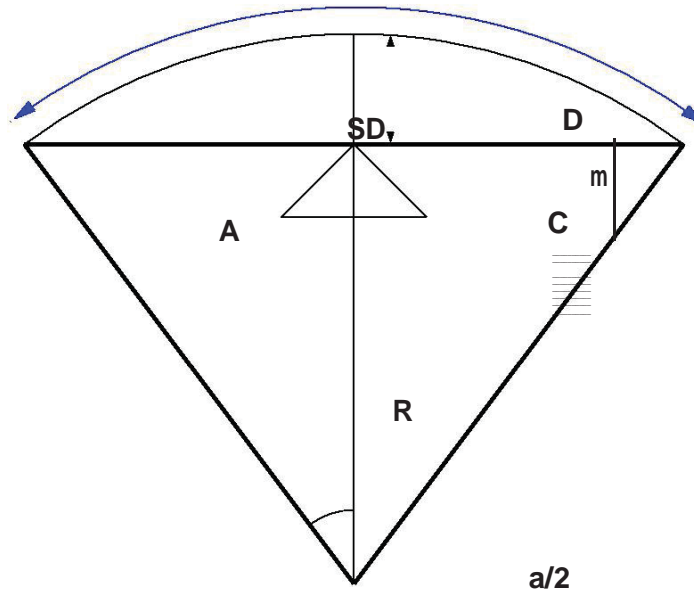

Figure 16:1: Set-back for single lane roads ($L_s < L_c$)

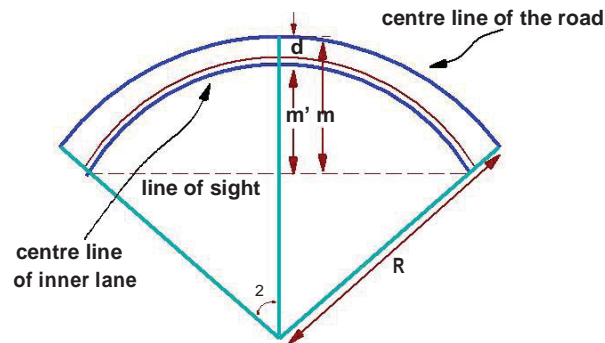

Figure 16:2: Set-back for multi-lane roads ($L_s < L_c$)

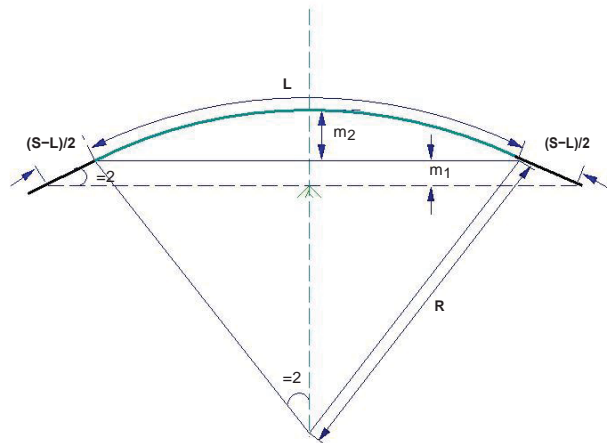

Figure 16:3: Set back for single lane roads ($L_s < L_c$)

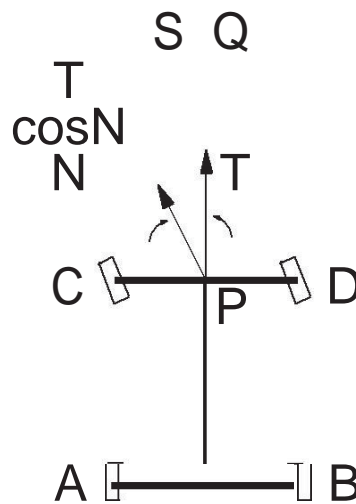

Figure 16:4: Curve resistance

Curve Resistance

When the vehicle negotiates a horizontal curve, the direction of rotation of the front and the rear wheels are different. The front wheels are turned to move the vehicle along the curve, whereas the rear wheels seldom turn. This is illustrated in figure 16:4. The rear wheels exert a tractive force T in the PQ direction. The tractive force available on the front wheels is $T \cos N$ in the PS direction as shown in the figure 16:4. This is less than the actual tractive force, T applied. Hence, the loss of tractive force for a vehicle to negotiate a horizontal curve is:

$$CR = T \sin N \quad (16.14)$$

Gradient

Gradient is the rate of rise or fall along the length of the road with respect to the horizontal. While

aligning a highway, the gradient is decided for designing the vertical curve. Before finalizing the gradients, the construction cost, vehicular operation cost and the practical problems in the site also has to be considered. Usually steep gradients are avoided as far as possible because of the difficulty to climb and increase in the construction cost. More about gradients are discussed below.

Effect of gradient

The effect of long steep gradient on the vehicular speed is considerable. This is particularly important in roads where the proportion of heavy vehicles is significant. Due to restrictive sight distance at uphill gradients the speed of traffic is often controlled by these heavy vehicles. As a result, not only the operating costs of the vehicles are increased, but also capacity of the roads will have to be reduced. Further, due to high differential speed between heavy and light vehicles, and between uphill and downhill gradients, accidents abound in gradients.

Representation of gradient

The positive gradient or the ascending gradient is denoted as $+n$ and the negative gradient as n . The deviation angle N is: when two grades meet, the angle which measures the change of direction and is given by the algebraic difference between the two grades $(n_1 - n_2) = n_1 + n_2 = i_1 + i_2$. Example: 1 in 30 = 3.33% 2° is a steep gradient, while 1 in 50 = 2% $1^\circ 10'$ is a gradient. The gradient representation is illustrated in the figure 17:1.

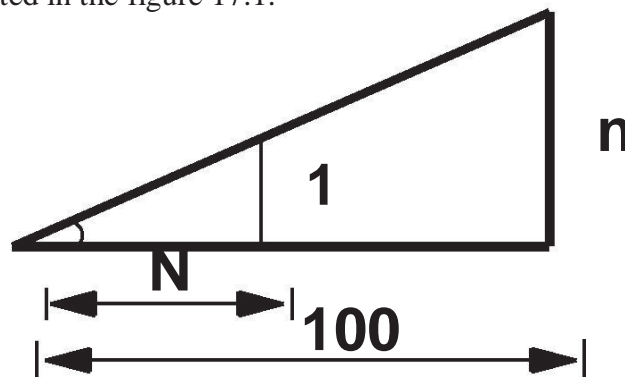

Figure 17:1: Representation of gradient

Terrain	Ruling	Limiting	Exceptional
Plain/Rolling	3.3	5.0	6.7
Hilly	5.0	6.0	7.0
Steep	6.0	7.0	8.0

Table 17:1: IRC Specifications for gradients for different roads

Types of gradient

Many studies have shown that gradient up to seven percent can have considerable effect on the speeds of the passenger cars. On the contrary, the speeds of the heavy vehicles are considerably

reduced when long gradients as at as two percent is adopted. Although, gradients are desirable, it is evident that the cost of construction will also be very high. Therefore, IRC has specified the desirable gradients for each terrain. However, it may not be economically viable to adopt such gradients in certain locations, steeper gradients are permitted for short duration. Different types of grades are discussed below and the recommended type of gradients for each type of terrain and type of gradient is given in table 17:1.

Ruling gradient, limiting gradient, exceptional gradient and minimum gradient are some types of gradients which are discussed below.

Ruling gradient

The ruling gradient or the design gradient is the maximum gradient with which the designer attempts to design the vertical profile of the road. This depends on the terrain, length of the grade, speed, pulling power of the vehicle and the presence of the horizontal curve. In terrain, it may be possible to provide at gradients, but in hilly terrain it is not economical and sometimes not possible also. The ruling gradient is adopted by the designer by considering a particular speed as the design speed and for a design vehicle with standard dimensions. But our country has a heterogeneous traffic and hence it is not possible to lay down precise standards for the country as a whole. Hence IRC has recommended some values for ruling gradient for different types of terrain.

Limiting gradient

This gradient is adopted when the ruling gradient results in enormous increase in cost of construction. On rolling terrain and hilly terrain it may be frequently necessary to adopt limiting gradient. But the length of the limiting gradient stretches should be limited and must be sandwiched by either straight roads or easier grades.

Exceptional gradient

Exceptional gradient are very steeper gradients given at unavoidable situations. They should be limited for short stretches not exceeding about 100 meters at a stretch. In mountainous and steep terrain, successive exceptional gradients must be separated by a minimum 100 metre length gentler gradient. At hairpin bends, the gradient is restricted to 2.5%.

Critical length of the grade

The maximum length of the ascending gradient which a loaded truck can operate without undue reduction in speed is called critical length of the grade. A speed of 25 kmph is a reasonable value. This value depends on the size, power, load, grad-ability of the truck, initial speed, nal desirable minimum speed etc.

Minimum gradient

This is important only at locations where surface drainage is important. Camber will take care of the lateral drainage. But the longitudinal drainage along the side drains requires some slope for smooth flow of water. Therefore minimum gradient is provided for drainage purpose and it depends on the rain fall, type of soil and other site conditions. A minimum of 1 in 500 may be sufficient for concrete drain and 1 in 200 for open soil drains are found to give satisfactory performance..

Creeper lane

When the uphill climb is extremely long, it may be desirable to introduce an additional lane so as to allow slow ascending vehicles to be removed from the main stream so that the fast moving vehicles are not affected. Such a newly introduced lane is called creeper lane. There are no hard and fast rules as when to introduce a creeper lane. But generally, it can be said that it is desirable to provide a creeper lane when the speed of the vehicle gets reduced to half the design speed. When there is no restrictive sight distance to reduce the speed of the approaching vehicle, the additional lane may be initiated at some distance uphill from the beginning of the slope. But when the restrictions are responsible for the lowering of speeds, obviously the lane should be initiated at a point closer to the bottom of the hill. Also the creeper lane should end at a point well beyond the hill crest, so that the slow moving vehicles can return back to the normal lane without any danger. In addition, the creeper lane should not end suddenly, but only in a tapered manner for efficient as well as safer transition of vehicles to the normal lane.

Grade compensation

While a vehicle is negotiating a horizontal curve, if there is a gradient also, then there will be increased resistance to traction due to both curve and the gradient. In such cases, the total resistance should not exceed the resistance due to gradient specified. For the design, in some cases this maximum value is limited to the ruling gradient

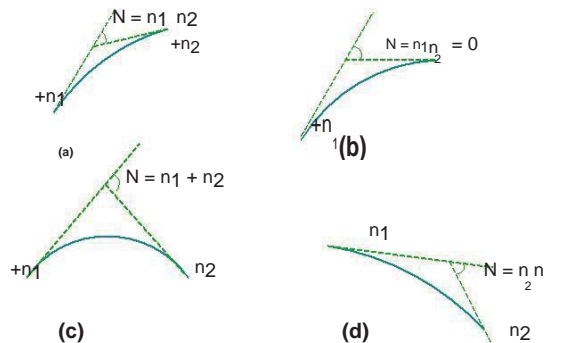

Figure 17:2: Types of summit curves

and in some cases as limiting gradient. So if a curve need to be introduced in a portion which has got the maximum permissible gradient, then some compensation should be provided so as to decrease the gradient for overcoming the tractive loss due to curve. Thus grade compensation can be defined as the reduction in gradient at the horizontal curve because of the additional tractive force required due to curve resistance ($T \cos N$), which is intended to o set the extra tractive force involved at the curve. IRC gave the following specification for the grade compensation.

1. Grade compensation is not required for grades flatter than 4% because the loss of tractive force is negligible.
2. Grade compensation is $\frac{30+R}{R}$ %, where R is the radius of the horizontal curve in meters.
3. The maximum grade compensation is limited to $\frac{75}{R}$ %

Summit curve

Summit curves are vertical curves with gradient upwards. They are formed when two gradients meet as

Illustrated in figure 17:2 in any of the following four ways:

- 2.3.2 When a positive gradient meets another positive gradient [figure 17:2a].
- 2.3.3 When positive gradient meets a at gradient [figure 17:2b]. .
- 2.3.4 When an ascending gradient meets a descending gradient [figure 17:2c]. .
- 2.3.5 When a descending gradient meets another descending gradient [figure 17:2d]. .

Type of Summit Curve

Many curve forms can be used with satisfactory results, the common practice has been to use parabolic curves in summit curves. This is primarily because of the ease with it can be laid out as well as allowing a comfortable transition from one gradient to another. Although a circular curve of equal sight distance at every point on the curve, for very small deviation angles a circular curve and parabolic curves are almost congruent. Furthermore, the use of parabolic curves was found to give excellent riding comfort.

Minimum gradient

This is important only at locations where surface drainage is important. Camber will take care of the lateral drainage. But the longitudinal drainage along the side drains requires some slope for smooth flow of water. Therefore minimum gradient is provided for drainage purpose and it depends on the rain fall, type of soil and other site conditions. A minimum of 1 in 500 may be sufficient for concrete drain and 1 in 200 for open soil drains are found to give satisfactory performance..

Gradient

Gradient is the rate of rise or fall along the length of the road with respect to the horizontal. While aligning a highway, the gradient is decided for designing the vertical curve. Before finalizing the gradients, the construction cost, vehicular operation cost and the practical problems in the site also has to be considered. Usually steep gradients are avoided as far as possible because of the difficulty to climb and increase in the construction cost. More about gradients are discussed below.

Figure 17:4: Length of summit curve ($L < S$)

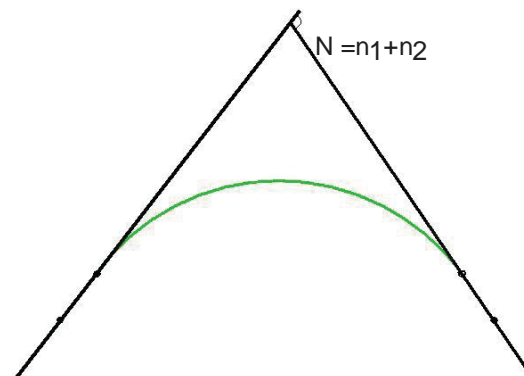

Valley curve

Valley curve or sag curves are vertical curves with convexity downwards. They are formed when two gradients meet as illustrated in figure 18:1 in any of the following four ways:

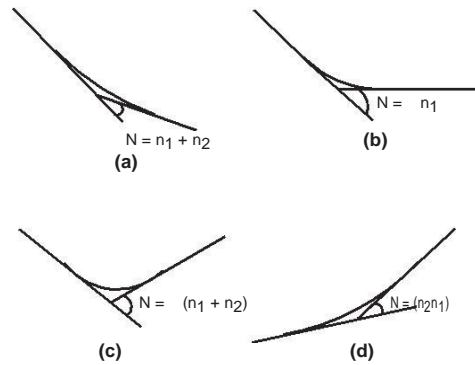

Figure 18:1: Types of valley curve

1. When a descending gradient meets another descending gradient [figure 18:1a].
2. When a descending gradient meets a horizontal gradient [figure 18:1b].
3. When a descending gradient meets an ascending gradient [figure 18:1c].
4. When an ascending gradient meets another ascending gradient [figure 18:1d].

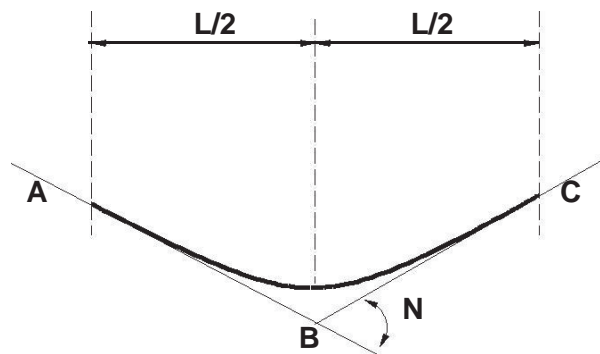

Figure 18:2: Valley curve details

Design considerations

There is no restriction to sight distance at valley curves during day time. But visibility is reduced during night. In the absence or inadequacy of street light, the only source for visibility is with the help of headlights. Hence valley curves are designed taking into account of headlight distance. In

valley curves, the centrifugal force will be acting downwards along with the weight of the vehicle, and hence impact to the vehicle will be more. This will result in jerking of the vehicle and cause discomfort to the passengers. Thus the most important design factors considered in valley curves are: (1) impact-free movement of vehicles at design speed and (2) availability of stopping sight distance under headlight of vehicles for night driving.

For gradually introducing and increasing the centrifugal force acting downwards, the best shape that could be given for a valley curve is a transition curve. Cubic parabola is generally preferred in vertical valley curves. See figure 18:2.

During night, under headlight driving condition, sight distance reduces and availability of stopping sight distance under head light is very important. The head light sight distance should be at least equal to the stopping sight distance. There is no problem of overtaking sight distance at night since the other vehicles with headlights could be seen from a considerable distance.

Length of the valley curve

The valley curve is made fully transitional by providing two similar transition curves of equal length. The transitional curve is set out by a cubic parabola $y = bx^3$ where $b = \frac{2N}{L^3}$. The length of the valley transition curve is designed based on two criteria:

1. Comfort criteria; that is allowable rate of change of centrifugal acceleration is limited to a comfortable level of about 0.6 m/sec^3 .
2. Safety criteria; that are the driver should have adequate headlight sight distance at any part of the country.

Comfort criteria

The length of the valley curve based on the rate of change of centrifugal acceleration that will ensure comfort: Let c is the rate of change of acceleration, R the minimum radius of the curve, v is the design speed and t is

the time, then c is given as:

$$\begin{aligned}
 c &= \frac{v^2}{R} \\
 &= \frac{v^2}{\frac{L}{v}} \\
 &= \frac{v^3}{LR} \\
 L &= \frac{v^3}{cR}
 \end{aligned}
 \tag{18.1}$$

For a cubic parabola, the value of R for length L_s is given by:

$$R = \frac{L}{N} \tag{18.2}$$

where L is the total length of valley curve, N is the deviation angle in radians or tangent of the deviation angle or the algebraic difference in grades, and c is the allowable rate of change of centrifugal acceleration which may be taken as 0.6 m/sec^3 .

Safety criteria

Length of the valley curve for headlight distance may be determined for two conditions: (1) length of the valley curve greater than stopping sight distance and (2) length of the valley curve less than the stopping sight distance.

Case 1 Length of valley curve greater than stopping sight distance ($L > S$)

The total length of valley curve L is greater than the stopping sight distance SSD. The sight distance available will be minimum when the vehicle is in the lowest point in the valley. This is because the beginning of the curve will have infinite radius and the bottom of the curve will have minimum radius which is a property of the transition curve. The case is shown in figure 18:3. From the geometry of the figure, we have:

$$\begin{aligned}
 h_1 + S \tan N &= aS^2 \\
 &= \frac{N S^2}{2L} \\
 L &= \frac{N S^2}{2h_1 + 2S \tan N}
 \end{aligned}
 \tag{18.4}$$

where N is the deviation angle in radians, h_1 is the height of headlight beam, θ is the head beam inclination in degrees and S is the sight distance. The inclination is 1 degree.

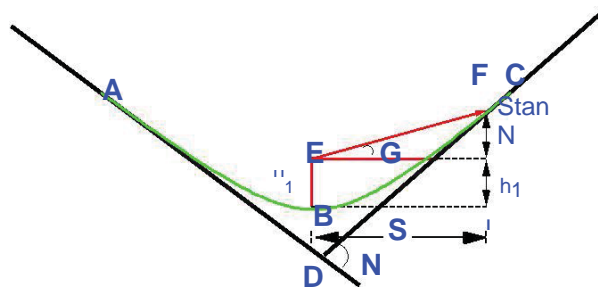

Figure 18:3: Valley curve, case 1, $L > S$

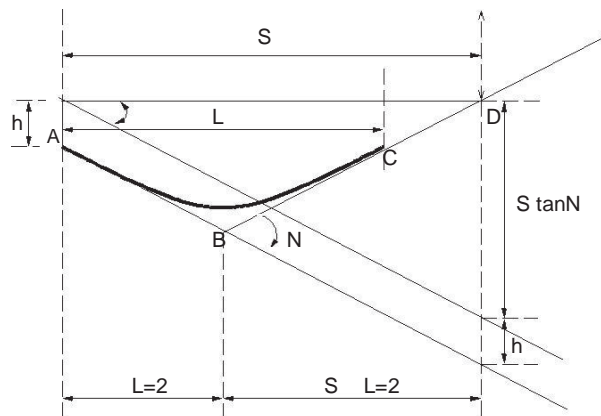

Figure 18:4: Valley curve, case 2, $S > L$

Case 2 Length of valley curve less than stopping sight distance ($L < S$)

The length of the curve L is less than SSD . In this case the minimum sight distance is from the beginning of the curve. The important points are the beginning of the curve and the bottom most part of the curve. If the vehicle is at the bottom of the curve, then its headlight beam will reach far beyond the endpoint of the curve whereas, if the vehicle is at the beginning of the curve, then the headlight beam will hit just outside the curve. Therefore, the length of the curve is derived by assuming the vehicle at the beginning of the curve. The case is shown in figure 18:4.

From the figure,

$$h_1 + s \tan N = S_2 \frac{N}{L}$$

$$L = 2S \frac{2h_1 + 2S \tan N}{N} \quad (18.5)$$

Note that the above expression is approximate and is satisfactory because in practice, the gradients are very small and is acceptable for all practical purposes. We will not be able to know prior to which case to be adopted. Therefore both has to be calculated and the one which satisfies the condition is adopted.