

Basics of Turbo MachineryLearning Objectives

At the end of this topic, you will be able to

- ⇒ Force exerted by fluid jet on stationary and moving normal and an inclined flat plate.
- ⇒ Force exerted by fluid jet on stationary and moving curved plate.
- ⇒ Working principle of an radial flow.

Learning Outcomes

By the end of this topic, you will be able to:

- ⇒ Explain how the force exerted by fluid jet on stationary and moving normal and an inclined flat plate.
- ⇒ Describe the movement of the force exerted by fluid jet on stationary and moving curved plate.
- ⇒ Explain the features which considered to be as a radial flow.

Introduction

- A jet of fluid emerging from a nozzle has some velocity as such it possesses a certain amount of kinetic energy.
- If this jet strikes an obstruction placed in its path, it will exert a force on the obstruction.
- This impressed force is known as impact of the jet and it is designated as hydrodynamic force.

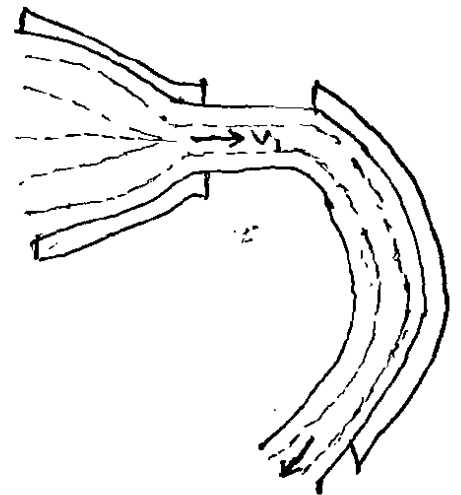

→ In order to distinguish it from the forces due to hydrostatic pressure.

→ Since a dynamic force is exerted by virtue of fluid motion, it always involves a change of momentum, whereas a force due to hydrostatic pressure implies no motion.

→ Hence the impulse-momentum principle may be utilized to evaluate the hydrodynamic force exerted on a body by a fluid jet.

Turbomachinery: In this, the following cases of impact of jet i.e., the force exerted by the jet on a plate, will be considered:

1. Force exerted by the jet on a stationary plate when

(a) Plate is vertical to the jet

(b) Plate is inclined to the jet, and

(c) Plate is curved

2. Force exerted by the jet on a moving plate, when

(a) Plate is vertical to the jet

(b) Plate is inclined to the jet, and

(c) Plate is curved.

Force F

Force exerted by the jet on a stationary vertical plate:

Consider a jet of water coming out from the nozzle, strikes a flat vertical plate as shown in fig.

Let V = velocity of the jet

d = Dia. of the jet

a = area of cross-section of the jet

$$= \frac{\pi d^2}{4}$$

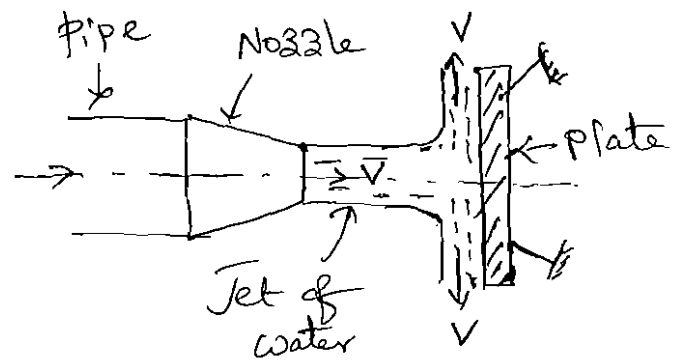

The jet after striking the plate, will move along the plate. But the plate is at right angles to the jet. Hence the jet after striking, will get deflected through 90° . Hence the component of the velocity of jet, in the direction of jet, after striking will be zero.

The force exerted by the jet on the plate in the direction of jet,

$$F_x = \frac{\text{Rate of change of momentum in the direction of force}}$$

$$= \frac{\text{Initial momentum} - \text{Final Momentum}}{\text{Time}}$$

$$= \frac{(\text{Mass} \times \text{Initial velocity} - \text{Mass} \times \text{Final Velocity})}{\text{Time}}$$

$$= \frac{\text{Mass}}{\text{Time}} \left[\text{Initial velocity} - \text{Final Velocity} \right]$$

$$F_x = \frac{\text{Mass}}{\text{Sec}} \left[\text{velocity of jet before striking} - \text{velocity of jet after striking} \right]$$

$$= \rho a V [V - 0] = \rho a V^2$$

While deriving above equation, we have taken initial velocity minus final velocity and not final velocity minus initial velocity. If the force exerted on the jet is to be calculated then final minus initial velocity is taken. But if the force exerted by the jet on the plate is to be calculated, then initial velocity minus final velocity is taken.

Force exerted by a jet on stationary Inclined Flat Plate.

Let a jet of water, coming out from the nozzle, strikes an inclined flat plate as shown in fig.

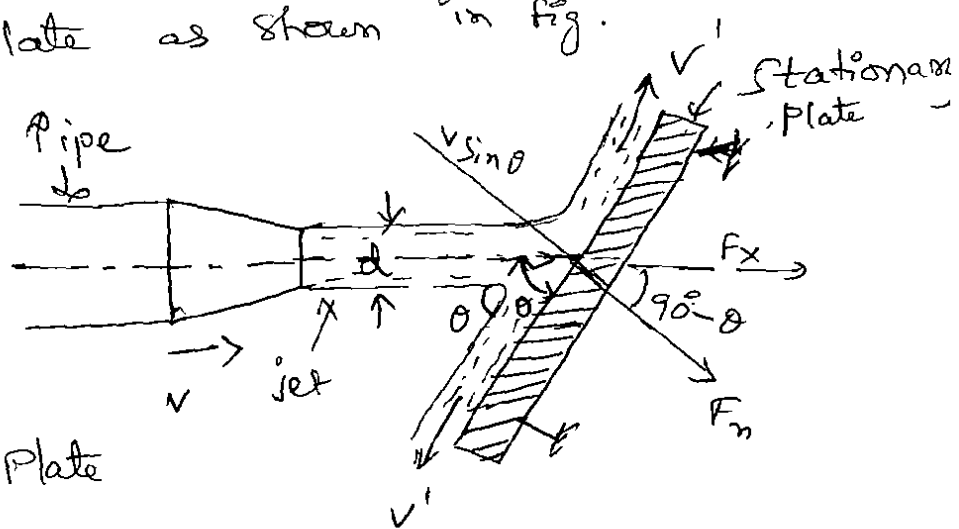

Let

a = area of jet

d = dia. of jet

θ = Angle b/w jet and Plate

V = velocity of jet

V' = Final velocity of jet

Because over plate is frictionless & smooth

$$\therefore \boxed{V' = V} \Rightarrow \text{Initial Velocity} = \text{Final Velocity}$$

4-3.

Force Exerted by the jet on the plate in the normal direction,

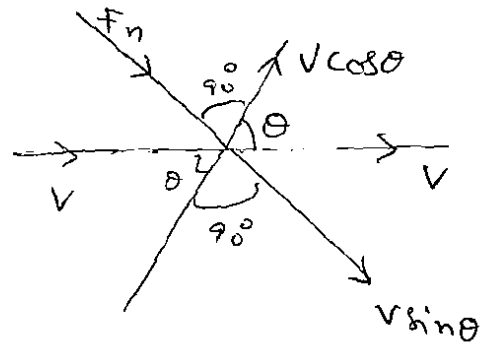

$$F_n = \text{change of momentum} \\ = \rho a v \text{ change in velocity}$$

$$F_n = \rho a v [\text{Initial velocity} - \text{final velocity}] \\ = \rho a v [V \sin \theta - 0] \quad \text{After striking the jet on plate} \\ = \rho a v (v \sin \theta)$$

$$\left. \begin{aligned} F_x &= F_n \sin \theta \\ F_y &= F_n \cos \theta \end{aligned} \right\}$$

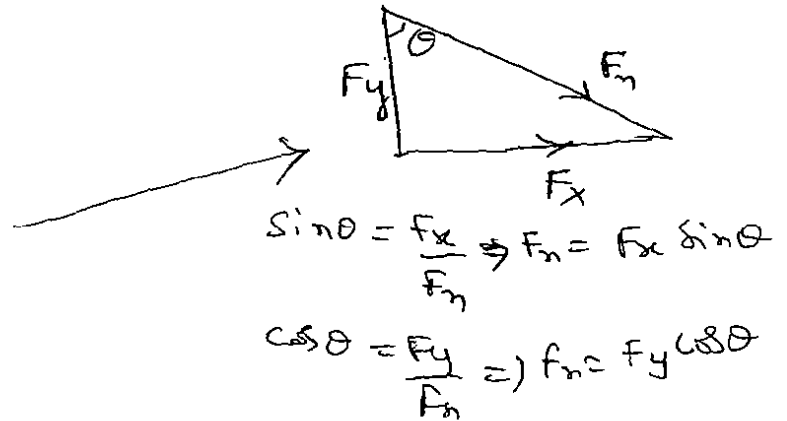

$$\therefore F_x = F_n (\sin \theta) = \rho a v (v \sin \theta) \cdot \sin \theta = \rho a v^2 \sin^2 \theta$$

$$\therefore F_y = F_n (\cos \theta) = \rho a v (v \sin \theta) \cos \theta = \rho a v^2 \sin \theta \cdot \cos \theta$$

Problems

on
Force exerted by a jet of water on stationary
Flat vertical & Inclined Plate.

- ① Force exerted by a jet of water of dia. 75mm on a stationary flat plate, when the jet strikes the plate normally with velocity of 20m/s.

Soln. Dia. of jet, $d = 75 \text{ mm} = 0.075 \text{ m}$
Area, $A = \frac{\pi}{4} (d)^2 = \frac{\pi}{4} (0.075)^2 = 0.004417 \text{ m}^2$

Velocity of jet, $V = 20 \text{ m/s}$.

\therefore Force exerted by jet of water on a stationary vertical plate is given by Equation is

$$\begin{aligned} F_x &= \rho a v^2 \\ &= 1000 \times 0.004417 \times 20^2 \\ &= \underline{1766.8 \text{ N}} \end{aligned}$$

② A 50 mm diameter jet having velocity of 25 m/s, strikes a flat plate the normal of which is inclined at an angle 30° to the area of the jet. Calculate the normal force exerted on the plate when plate is stationary?

Sol:

Dia of jet, $d = 50 \text{ mm} = 0.05 \text{ m}$

velocity of jet, $V = 25 \text{ m/s}$

$$\theta = 90^\circ - 30^\circ = 60^\circ$$

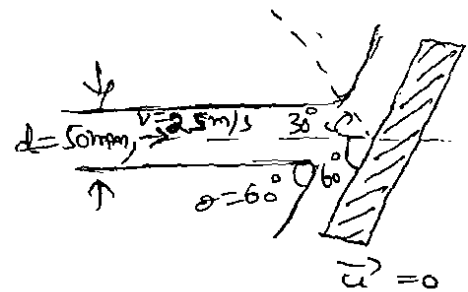

Normal force exerted by the jet on the plate is

$$\begin{aligned} F_n &= \rho a v^2 \sin \theta \\ &= 1000 \times \frac{\pi (0.05)^2}{4} \times 25^2 \times \sin 60 \end{aligned}$$

$$F_n = 1062.77 \text{ N}$$

- ③ A jet of water of dia. 30mm strikes a fixed plate in such a way that the angle between the plate and the jet is 30° . The force exerted in the direction of jet is 1471.5N. Determine the rate of flow of water.

Sol:

$$\text{Dia. of jet } d = 30\text{mm} = 0.03\text{m}$$

$$\text{Area of jet, } a = \frac{\pi}{4}(0.03)^2 = 0.0007068\text{m}^2$$

$$\text{Angle of jet w/plate, } \theta = 30^\circ.$$

Force exerted in the direction of jet, $F_x = 1471.5\text{N}$.

force in the direction of jet is given by equation,

$$F_x = \rho a v^2 \sin^2 \theta$$

As the force is given in Newton's the value of ' ρ ' should be taken equal to 1000kg/m^3 .

$$\therefore 1471.5 = 1000 \times 0.0007068 \times v^2 \times \sin^2 30^\circ$$

$$v^2 = 3000 \Rightarrow v = 54.77\text{m/s}$$

\therefore Discharge, $Q = \text{Area} \times \text{Velocity}$

$$Q = 0.0007068 \times 54.77$$

$$Q = 0.0387\text{m}^3/\text{s}$$

— . — .

Force exerted by a stationary Curved Plate.

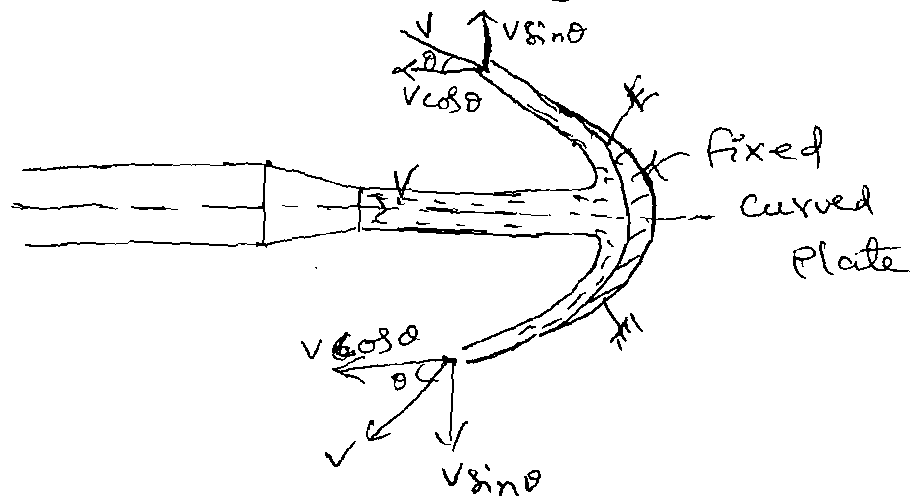

Let a jet of water strikes a fixed curved plate at the centre as shown in fig. The jet after striking the plate, comes out with the same velocity if the plate is smooth and there is no loss of energy due to impact of the jet, in the tangential direction of the curved plate.

The velocity at outlet of the plate can be resolved into two components, one in the direction of jet & other component perpendicular to the direction of jet.

Component of velocity in the direction of jet, $V_2 \cos$

$$V_2 \cos = -\cos \theta \quad (\text{ve means opposite direction to } V)$$

Component of velocity perpendicular to jet = $V \sin \theta$

Force exerted by the jet in the direction of jet

$$F_x = \text{mass per sec} (V_1 \cos - V_2 \cos)$$

4-5.

where V_{1x} = Initial velocity in the direction of jet = V

V_{2x} = Final velocity in the direction of jet = $-V \cos \theta$

$$\begin{aligned}\therefore F_x &= \rho a v [V - (-v \cos \theta)] \\ &= \rho a v [V + v \cos \theta] \\ &= \rho a v^2 [1 + \cos \theta]\end{aligned}$$

Similarly, $F_y = \text{Mass per sec} \times [V_{1y} - V_{2y}]$

where V_{1y} = Initial velocity in the direction of $y = 0$

V_{2y} = Final velocity in the direction of $y = V \sin \theta$

$$\therefore F_y = \rho a v [0 - v \sin \theta] = -\rho a v^2 \sin \theta.$$

-ve sign means that force is acting in the downward direction. In this case the angle of deflection of the jet = $(180 - \theta)$.

www.jntufastupdates.com

Problem

① A jet of water of diameter 50mm moving with a velocity of 40m/s, strikes a curved fixed symmetrical plate at the centre. Find the force exerted by the jet of water in the direction of the jet, if the jet is deflected through an angle of 120° at the outlet of the curved plate.

Sol:

Dia. of the jet,

$$d = 50\text{mm} = 0.05\text{m}$$

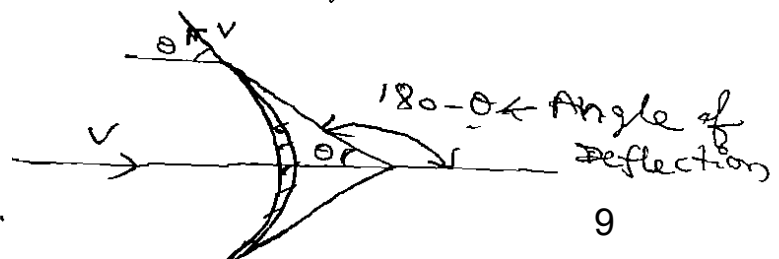

$$\therefore \text{Area, } a = \frac{\pi}{4} (0.05)^2 = 0.001963 \text{ m}^2$$

Velocity of jet, $V = 40 \text{ m/s}$

Angle of deflection = 120°

The Angle of deflection b/w jet & plate = $180 - \theta$
 $= 180 - 120 = 60^\circ$

\therefore Force exerted by the jet on the curved plate in the direction of the jet is given by equation is

$$F_x = \rho a v^2 [1 + \cos \theta]$$

$$= 1000 \times 0.001963 \times 40^2 [1 + \cos 60^\circ]$$

$$F_x = 4711.15 \text{ N}$$

Force Exerted by a jet on a Hinged Plate:

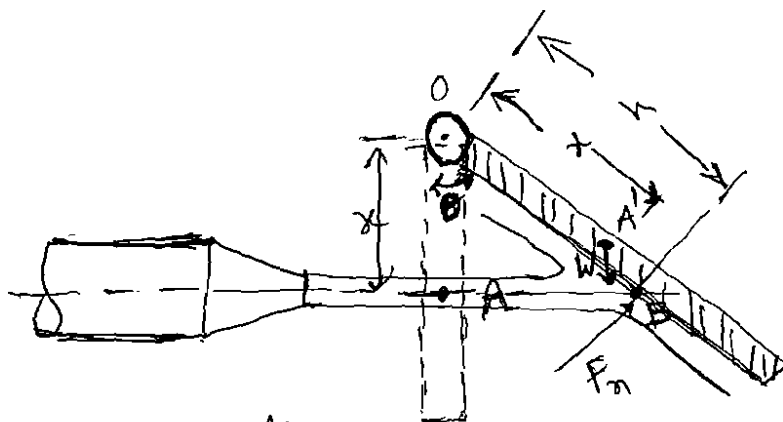

Consider a jet of water striking a vertical plate at the centre which is hinged at 'O'.

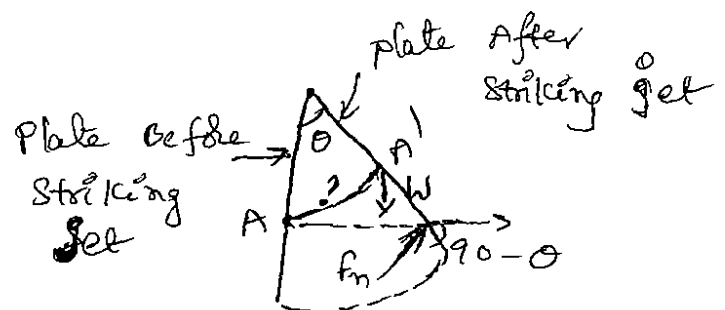

4-6.

Due to the force exerted by the jet on the plate, the plate will swing through some angle about the hinge as shown in figure.

Let $x =$ distance of centre of jet from hinge O .

$\theta =$ angle of swing about hinge

$W =$ Weight of plate acting at C.G. of the plate.

The dotted lines show the position of the plate, before the jet strikes the plate. The point A on the plate will be A' after the jet strikes the plate. The distance

$OA = OA' = x$. Let the weight of the plate is acting at A' . When the plate is in equilibrium after the jet strikes the plate, the moment of all the forces about the hinge must be zero.

Two forces are acting on the plate. They are:

1. Force due to jet of water, normal to the plate

$$F_n = \rho a v^2 \sin \theta'$$

where $\theta' =$ Angle b/w jet & plate $= (90^\circ - \theta)$

2. Weight of the plate, W

$$\left(\because OB = \frac{OA}{\cos \theta} \right)$$

Moment of force F_n about hinge $= F_n \times OB$

$$= \rho a v^2 \sin(90^\circ - \theta) \times OB$$

$$= \rho a v^2 \cos \theta \times OA$$

$$= \rho a v^2 \times OA = \rho a v^2 x$$

$$\sin \theta = \frac{?}{OA}$$

Moment of weight w about hinge

$$= Wx ? = W \times OA' \sin \theta$$

$$OA' \sin \theta = ?$$

$$= W \times x \times \sin \theta$$

For equilibrium of the plate, $\rho a v^2 x = W \times x \sin \theta$

$$\sin \theta = \frac{\rho a v^2}{W}$$

from above eq. the angle of swing of the plate about hinge can be calculated.

Problem

1. A jet of water of 2.5 cm diameter, moving with a velocity of 10 m/s, strikes a hinged square plate of weight 98.1 N at the centre of the plate. The plate is of uniform thickness. Find the angle through which the plate will swing.

Sol: Given:

Dia. of jet, $d = 2.5 \text{ cm} = 0.025 \text{ m}$

velocity of jet, $V = 10 \text{ m/s}$

Weight of plate, $W = 98.1 \text{ N}$

Area of jet, $a = \frac{\pi}{4} (d^2) = \frac{\pi}{4} (0.025)^2 = 0.00049 \text{ m}^2$

4-7

The angle through which the plate will swing is given by equation is

$$\sin \theta = \frac{\rho a v^2}{W} = \frac{1000 \times 0.00049 \times 10^2}{98.1}$$

$$= 0.499$$

$$\therefore \theta = 29.96^\circ$$

Force on Flat Vertical Plate Moving in the Direction of Jet

Fig. shows a jet of water striking a flat vertical plate moving with a uniform velocity away from the jet.

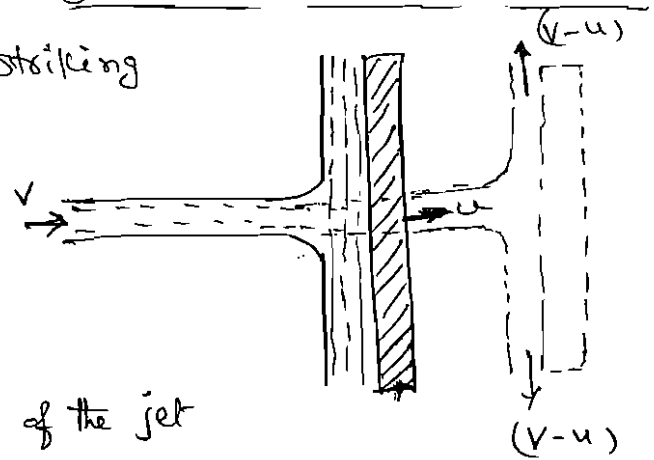

Let $V =$ Absolute velocity of the jet
 $a =$ Area of $\frac{1}{2}$ s of the jet
 $u =$ Velocity of the flat plate.

In this case, the jet does not strike the plate with a velocity V , but it strikes with a relative velocity, which is equal to the absolute velocity of jet of water minus the velocity of the plate.

Hence relative velocity of the jet with respect to plate

$$= (V-u)$$

Mass of water striking the plate per sec
 $= \rho \times \text{Area of jet} \times \text{velocity with which jet strikes the plate}$
 $= \rho a (V-u)$

∴ Force exerted by the jet on the moving plate in the direction of the jet,

$$\begin{aligned}
 F_x &= \text{Mass of water striking per sec} \times \\
 &\quad \left[\text{Initial velocity with which water strikes} - \right. \\
 &\quad \left. \text{final velocity} \right] \\
 &= \rho a (v-u) [+(v-u) - 0] \\
 &= \rho a (v-u)^2.
 \end{aligned}$$

In this case, the work will be done by the jet on the plate, as plate is moving.

For the stationary plates, the work done is zero

$$\begin{aligned}
 \therefore \text{Work done per second by the jet on the plate} \\
 &= F_x \times \frac{\text{Distance in the direction of } F_x}{\text{Time}}
 \end{aligned}$$

www.Jntufastupdates.com

$$= F_x \times u = \rho a (v-u)^2 \times u.$$

→ Force on the Inclined Plate Moving in the Direction of the Jet :

Let a jet of water strikes an inclined plate, which is moving with a uniform

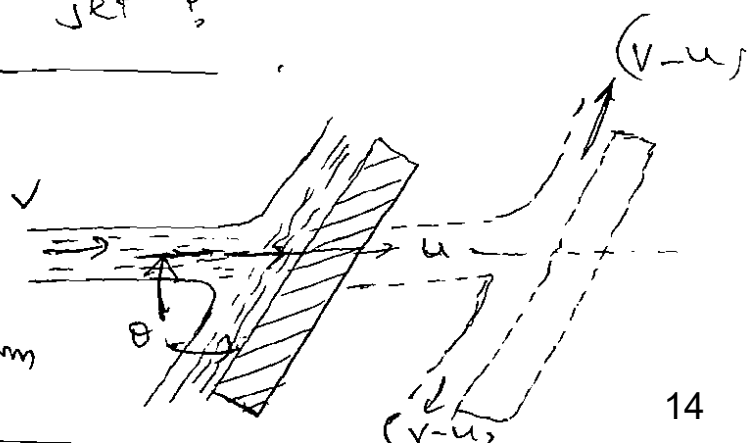

Q-8.

Velocity in the direction of the jet as shown in fig.

Let $V =$ Absolute Velocity of jet of water

$u =$ Velocity of the plate in the direction of jet

$a =$ cross-sectional area of jet, and

$\theta =$ Angle between jet and plate

Relative Velocity of jet of water $= (V-u)$

\therefore The velocity with which jet strikes $= (V-u)$

Mass of water striking per second

$$= \rho a (V-u)$$

If the plate is smooth and loss of energy due to impact of the jet is assumed zero, the jet of water will leave the inclined plate with a velocity equal to $(V-u)$.

The force exerted by the jet of water on the plate in the direction normal to the plate is given as

$$\begin{aligned} F_n &= \text{Mass striking per second} \times [\text{Initial velocity in the normal direction with which jet strikes} \\ &\quad - \text{Final velocity}] \\ &= \rho a (V-u) [+(V-u) \sin \theta - 0] = \rho a (V-u)^2 \sin \theta \end{aligned}$$

This normal force F_n is resolved into two components namely F_x & F_y in the direction of the jet & perpendicular to the direction of the jet respectively

$$\therefore F_x = F_n \sin \theta = \rho a (v-u)^2 \sin^2 \theta$$

$$F_y = F_n \cos \theta = \rho a (v-u)^2 \sin \theta \cdot \cos \theta.$$

\therefore Work done per second by the jet on the plate

$$= F_x \times \text{Distance per second in the direction of } x.$$

$$= F_x \times u = \rho a (v-u)^2 \sin^2 \theta \times u$$

$$= \rho a (v-u)^2 u \cdot \sin^2 \theta \cdot \text{Nm/s},$$

Force on the curved plate when the plate is moving in the direction of jet:-

Let a jet of water strikes a curved plate at the centre of the plate which is moving with a uniform velocity in the direction of the jet as shown in fig.

Let v = Absolute velocity of jet,
 a = Area of jet
 u = velocity of the plate in the direction of jet.

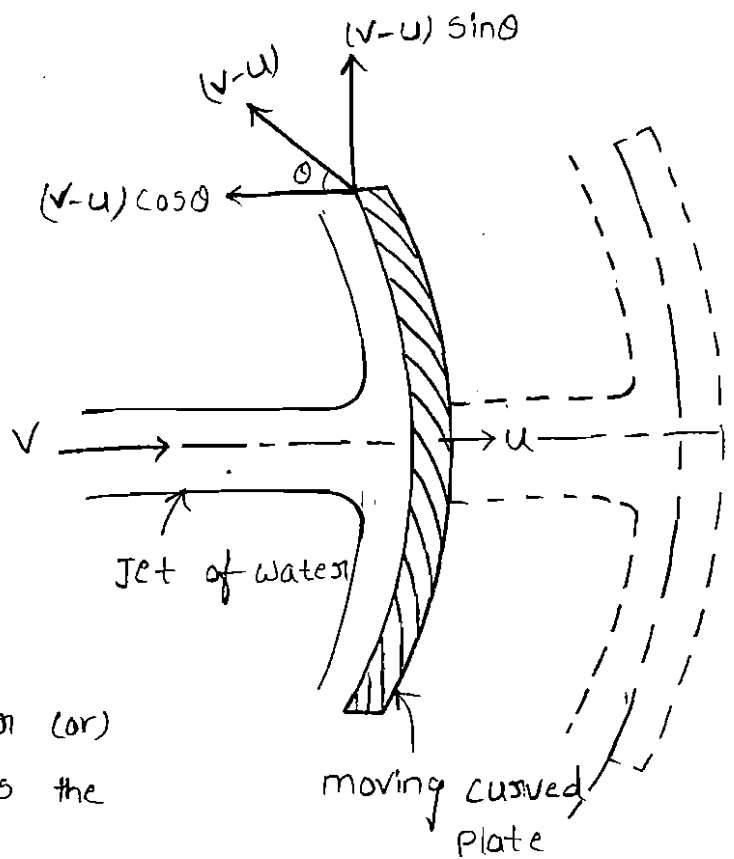

Relative velocity of the jet of water (or)
 The velocity with which jet strikes the curved plate = $(v-u)$

If plate is smooth and the loss of energy due to impact of jet is zero,

then the velocity with which the jet will be leaving the curved vane = $(v-u)$

This velocity can be resolved into two components, one in the direction of the jet and other perpendicular to the direction of the jet.

Component of the velocity in the direction of jet = $-(v-u)\cos\theta$.

[-ve sign is taken as at the outlet, the component is in the opposite direction of the jet].

Component of the velocity in the direction perpendicular to the direction of jet = $(v-u)\sin\theta$.

mass of the water striking the plate = $\rho \times a \times$ velocity with which jet strikes the plate
 $= \rho \times a \times (v-u)$

\therefore force exerted by the jet of water on the curved plate in the direction of the jet.

$$\begin{aligned}
 f_x &= \text{mass striking per sec} \times [\text{Initial velocity with which jet strikes} \\
 &\quad \text{the plate in the direction of jet} - \text{final velocity}] \\
 &= \rho a(v-u) [(v-u) - (-(v-u)\cos\theta)] \\
 &= \rho a(v-u) [(v-u) + (v-u)\cos\theta] \\
 &= \rho a(v-u)^2 [1 + \cos\theta]
 \end{aligned}$$

$$\begin{aligned}
 \text{Work done by the jet on the plate per second} \\
 &= f_x \times \text{Distance travelled per second in the direction of } x \\
 &= f_x \times u \\
 &= \rho a(v-u)^2 [1 + \cos\theta] \times u \\
 &= \rho a(v-u)^2 \times u [1 + \cos\theta].
 \end{aligned}$$

Problem-1

A jet of water of diameter 7.5cm strikes a curved plate as its centre with a velocity of 20m/s. The curved plate is moving with a velocity of 8m/s in the direction of the jet. The jet is deflected through an angle of 165° . Assuming the plate smooth. find

- i) force exerted on the plate in the direction of jet,
- ii) Power of the jet, and
- iii) efficiency of the jet.

Soln Given data

Diameter of the jet, $d = 7.5\text{cm} = 0.075\text{m}$

$$\therefore \text{Area}, a = \frac{\pi}{4} (0.075)^2 = 0.004417$$

velocity of the jet, $v = 20\text{m/s}$

velocity of the plate, $u = 8\text{m/s}$

Angle of deflection of the jet, $= 165^\circ$

\therefore Angle made by the relative velocity at the outlet of the plate,

$$\theta = 180^\circ - 165^\circ$$

$$\theta = 15^\circ$$

i) force exerted by the jet on the plate in the direction of the jet is ②
given by equation = $f_x = \rho a (v-u)^2 (1 + \cos \theta)$

$$= 1000 \times 0.004417 (20-8)^2 (1 + \cos 15^\circ)$$
$$= 1250.38 \text{ N}$$

ii) work done by the jet on the plate per second

$$= f_x \times u$$
$$= 1250.38 \times 8$$
$$= 10003.04 \text{ N-m/s}$$

$$\therefore \text{power of the jet} = \frac{10003.04}{1000} = 10 \text{ kW}$$

iii) efficiency of the jet = $\frac{\text{output}}{\text{input}} = \frac{\text{work done by jet/sec}}{\text{Kinetic energy of jet/sec}}$

$$= \frac{1250.38 \times 8}{\frac{1}{2} (\rho a v) \times v^2}$$

$$= \frac{1250.38 \times 8}{\frac{1}{2} \times 1000 \times 0.004417 \times v^3}$$

$$= \frac{1250.38 \times 8}{\frac{1}{2} \times 1000 \times 0.004417 \times (20)^3}$$

$$= 0.564$$

$$= 56.4 \%$$

www.Jntufastupdates.com

force exerted on a series of radial curved vanes:-

For a radial curved vane, the radius of the vane at inlet and outlet is different and hence the tangential velocities of the radial vane at inlet and outlet will not be equal. Consider a series of radial curved vanes mounted on a wheel as shown in fig. The jet of water strikes the vanes and the wheel starts rotating at a constant angular speed.

Let R_1 = Radius of wheel at inlet of the vane.

R_2 = Radius of wheel at the outlet of the vane.

ω = Angular speed of the wheel

then $u_1 = \omega R_1$ and $u_2 = \omega R_2$

The velocity triangles at inlet and outlet are drawn as shown in fig.

The mass of water striking per second for a series of vanes = mass of water coming out from nozzle per second.

$$= \rho a v_1$$

Where a = Area of jet and

v_1 = velocity of jet fig. series of radial curved vanes mounted on a wheel

Momentum of water striking the vanes in the tangential direction per sec at inlet = mass of water per second \times component of v_1 in the tangential direction.

$$= \rho a v_1 \times v_{w1} \quad (\because \text{component of } v_1 \text{ in tangential direction is } v_1 \cos \alpha = v_{w1})$$

Similarly, momentum of water at outlet per sec

$$= \rho a v_2 \times \text{component of } v_2 \text{ in the tangential direction}$$

$$= \rho a v_2 \times (-v_2 \cos \beta)$$

$$= -\rho a v_2 \times v_{w2} \quad (v_2 \cos \beta = v_{w2})$$

[$-v_2$ sign is taken as the velocity v_2 at outlet is in opposite direction].

Now, Angular momentum per second at inlet

$$= \text{momentum at inlet} \times \text{Radius at inlet}$$

$$= \rho a v_1 \times v_{w1} \times R_1$$

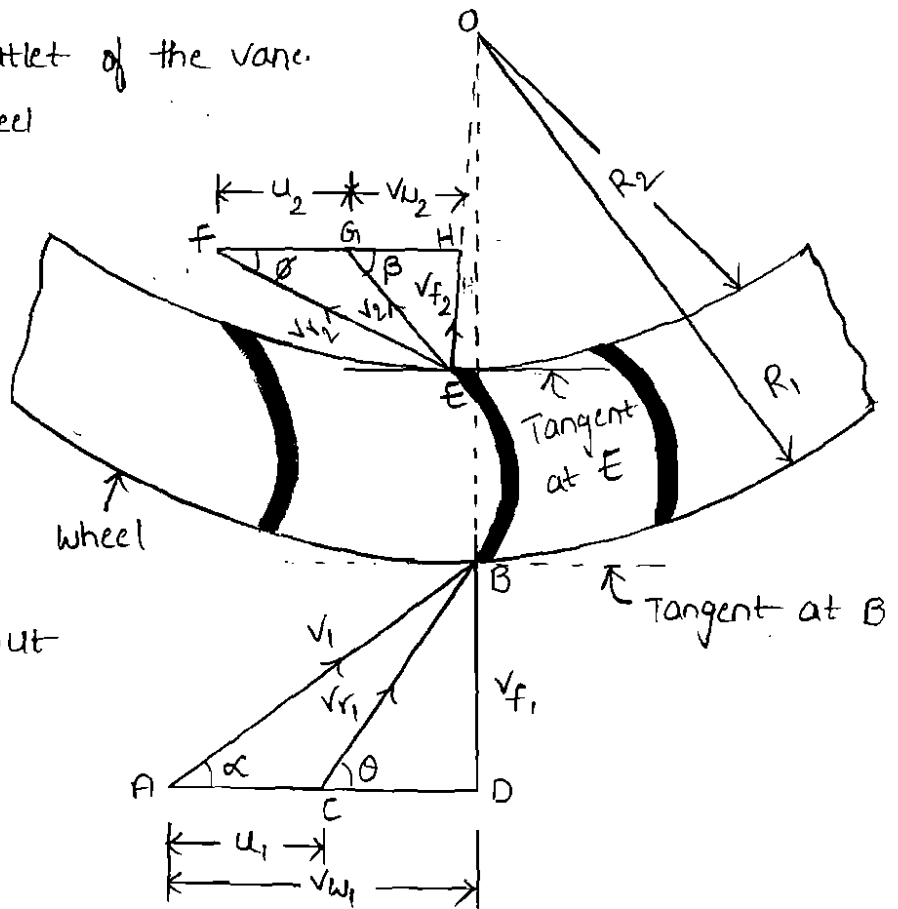

Angular momentum per second at outlet
 = momentum of outlet x Radius at outlet
 = $-\rho a v_1 \times v_{w2} \times R_2$

Torque exerted by the water on the wheel

$T =$ Rate of change of angular momentum
 = [Initial angular momentum per second - final angular momentum per second]
 = $\rho a v_1 \times v_{w1} \times R_1 - (-\rho a v_1 \times v_{w2} \times R_2)$
 = $\rho a v_1 [v_{w1} \times R_1 + v_{w2} \times R_2]$

Work done per second on the wheel

= Torque x Angular velocity
 = $T \times \omega$
 = $\rho a v_1 [v_{w1} \times R_1 + v_{w2} \times R_2] \times \omega$
 = $\rho a v_1 [v_{w1} \times R_1 \times \omega + v_{w2} \times R_2 \times \omega]$
 = $\rho a v_1 [v_{w1} u_1 + v_{w2} u_2]$ ($\because u_1 = \omega R_1, u_2 = \omega R_2$)

If the angle β in fig is an obtuse angle then work done per second will be given as = $\rho a v_1 [v_{w1} u_1 \pm v_{w2} u_2]$

If the discharge is radial at outlet, then $\beta = 90^\circ$ and work done becomes as = $\rho a v_1 [v_{w1} u_1]$ ($\because v_{w2} = 0$)

Efficiency of radial curved vane:-

The work done per second on the wheel is the output of the system whereas the initial kinetic energy per second of the jet is the input.

Hence the efficiency of the system is expressed as

Efficiency, $\eta = \frac{\text{Work done per second}}{\text{Kinetic energy per second}} = \frac{\rho a v_1 [v_{w1} u_1 \pm v_{w2} u_2]}{\frac{1}{2} (\text{mass/sec}) \times v_1^2}$
 = $\frac{\rho a v_1 [v_{w1} u_1 \pm v_{w2} u_2]}{\frac{1}{2} (\rho a v_1) \times v_1^2} = \frac{2 [v_{w1} u_1 \pm v_{w2} u_2]}{v_1^2}$

If there is no loss of energy when water is flowing over the vanes, the work done on the wheel per second is also equal to the change in kinetic energy of the jet per second. Hence, the work done per second on the wheel is also given as

Work done per second on the wheel

= change of K.E per second of the jet

= (Initial K.E. per second - final K.E. per second) of the jet

$$= \left(\frac{1}{2} m v_1^2 - \frac{1}{2} m v_2^2 \right)$$

$$= \frac{1}{2} m (v_1^2 - v_2^2)$$

(\because mass/second = $\rho a v_1$)

$$= \frac{1}{2} (\rho a v_1^2) (v_1^2 - v_2^2)$$

Hence efficiency, $\eta = \frac{\text{Work done per second on the wheel}}{\text{Initial K.E. per second of the jet}}$

$$= \frac{\frac{1}{2} \rho a v_1^2 (v_1^2 - v_2^2)}{\frac{1}{2} (\rho a v_1^2) \cdot v_1^2}$$

$$\frac{1}{2} (\rho a v_1^2) \cdot v_1^2$$

$$= \frac{v_1^2 - v_2^2}{v_1^2}$$

$$= \left(1 - \frac{v_2^2}{v_1^2} \right)$$

Force exerted by a jet of water on an unsymmetrical moving curved plate when jet strikes tangentially at one of the tips:-

fig. shows a jet of water striking a moving curved plate (also called vane) tangentially, at one of its tips. As the jet strikes tangentially, the loss of energy due to impact of the jet will be zero. In this case as plate is moving, the velocity with which jet of water strikes is equal to the relative velocity of the jet with respect to the plate. Also as the plate is moving in different direction of the jet, the relative velocity at inlet will be equal to the vector difference of the

Velocity of jet and velocity of the plate at inlet.

Let v_1 = velocity of the jet at inlet.

u_1 = velocity of the plate (vane) at inlet.

v_{r1} = Relative velocity of jet and plate at inlet.

α = Angle between the direction of the jet and direction of motion of the plate, also called guide blade angle.

θ = Angle made by the relative velocity (v_{r1}) with the direction of motion at inlet also called vane angle at inlet.

v_{w1}, v_{f1} = The components of velocity of jet v_1 , in the direction of motion and perpendicular to the direction of motion of the vane respectively.

v_{w1} = It is also known as velocity of whirl at inlet.

v_{f1} = It is also known as velocity of flow at inlet.

v_2 = velocity of the jet, leaving the vane (or) velocity of jet at outlet of the vane.

u_2 = velocity of the vane at outlet.

v_{r2} = Relative velocity of the jet with respect to the vane at outlet.

β = Angle made by the velocity v_2 with the direction of motion of the vane at outlet.

ϕ = Angle made by the relative velocity v_{r2} with the direction of motion of the vane at outlet and also called vane angle at outlet.

v_{w2}, v_{f2} = Components of the velocity v_2 , in the direction of motion of vane at outlet and perpendicular to the direction of motion of vane at outlet.

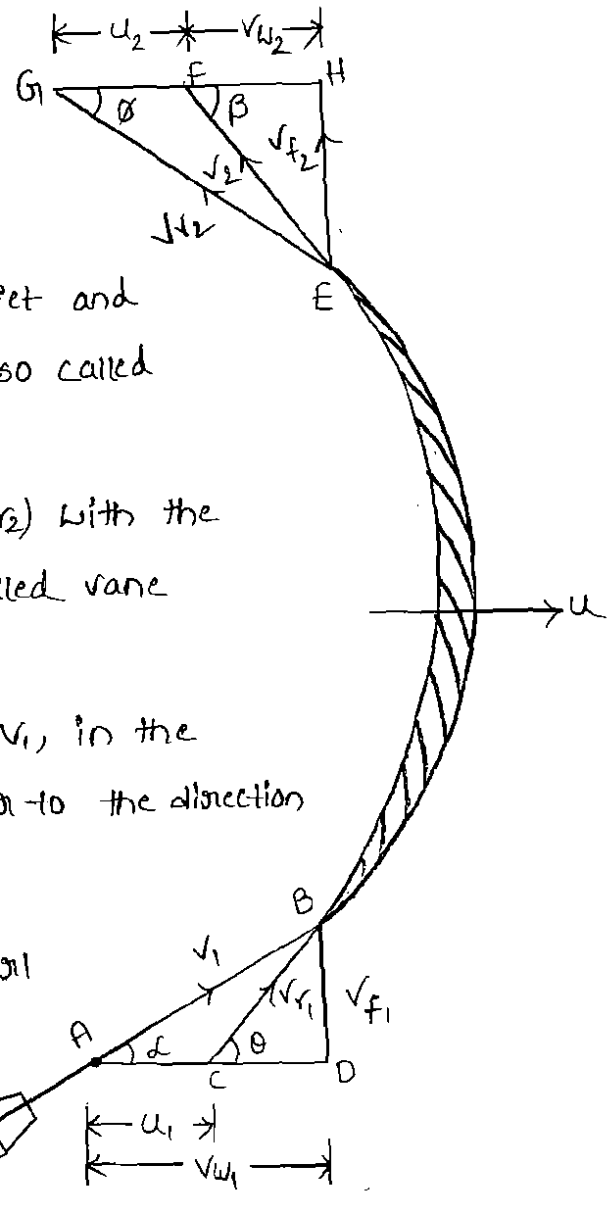

Fig. Jet striking a moving curved vane at one of the tip:

V_{w2} = It is also called the velocity of whirl at outlet.

V_{f2} = velocity of flow at outlet.

The triangles ABD and EGH are called the velocity triangles at inlet and outlet.

∴ force exerted by the jet in the direction of motion.

$$F_x = \text{mass of water striking per sec} \times [\text{initial velocity with which jet strikes in the direction of motion} - \text{final velocity of jet in the direction of motion}] \quad \text{--- (1)}$$

But initial velocity with which jet strikes the vane $= V_{r1}$

The component of this velocity in the direction of motion

$$= V_{r1} \cos \theta = (V_{w1} - u_1)$$

Similarly the component of the relative velocity at outlet in the direction of motion $= -V_{r2} \cos \phi$

$$= -(u_2 + V_{w2})$$

[ve sign is taken as the component of V_{r2} in the direction of motion is in the opposite direction].

mass of water striking the vane per second $= \rho a V_{r1}$

substituting all the values in equation (1)

$$F_x = \rho a V_{r1} [(V_{w1} - u_1) - \{-(u_2 + V_{w2})\}]$$

$$= \rho a V_{r1} [V_{w1} - u_1 + u_2 + V_{w2}]$$

$$= \rho a V_{r1} [V_{w1} + V_{w2}] \quad \text{--- (2)} \quad (\because u_1 = u_2)$$

Equation (2) is true only when angle β shown in fig is an acute angle. If $\beta = 90^\circ$, then $V_{w2} = 0$, then equation (2) becomes as

$$F_x = \rho a V_{r1} [V_{w1}]$$

If β is an obtuse angle, the expression for F_x will become

$$F_x = \rho a V_{r1} [V_{w1} - V_{w2}]$$

Thus in general, F_x is written as $F_x = \rho a v_1 [v_{w1} \pm v_{w2}]$

work done per second on the vane by the jet

$$= \text{force} \times \text{distance per second in the direction of force}$$

$$= F_x \times u$$

$$= \rho a v_1 [v_{w1} \pm v_{w2}] \times u$$

∴ work done per second per unit weight of fluid striking per second

$$= \frac{\rho a v_1 [v_{w1} \pm v_{w2}] \times u}{\text{weight of fluid striking/s}} \quad \frac{\text{Nm/s}}{\text{N/s}}$$

$$= \frac{\rho a v_1 [v_{w1} \pm v_{w2}] \times u}{g \times \rho a v_1} = \text{Nm/N}$$

$$= \frac{1}{g} [v_{w1} \pm v_{w2}] \times u \quad \text{Nm/N}$$

work done per second per unit mass of fluid striking per second

$$= \frac{\rho a v_1 [v_{w1} \pm v_{w2}] \times u}{\text{mass of fluid striking/s}} \quad \frac{\text{Nm/s}}{\text{kg/s}}$$

$$= \frac{\rho a v_1 [v_{w1} \pm v_{w2}] \times u}{\rho a v_1} \quad \text{Nm/kg}$$

$$= (v_{w1} \pm v_{w2}) \times u \quad \text{Nm/kg}$$

www.jntufastupdates.com

Efficiency of jet

$$\eta = \frac{\text{output}}{\text{input}} = \frac{\text{work done per second on the vane}}{\text{Initial K.E per second of the jet}}$$

$$= \frac{\rho a v_1 (v_{w1} \pm v_{w2}) \times u}{\frac{1}{2} m v_1^2}$$

where

m = mass of the fluid per second in the jet = $\rho a v_1$

v_1 = initial velocity of jet

$$\eta = \frac{\rho a v_1 [v_{w1} \pm v_{w2}] \times u}{\frac{1}{2} (\rho a v_1) \times v_1^2}$$

force exerted by a jet of water on a series of vanes:-

The force exerted by a jet of water on a single moving plate (which may be flat (or) curved) is not practically feasible. This case is only a theoretical one. In actual practice, a large number of plates are mounted on the circumference of a wheel at a fixed distance apart as shown in fig. The jet strikes a plate and due to the force exerted by the jet on the plate, the wheel starts moving and the 2nd plate mounted on the wheel appears before the jet, which again exerts the force on the 2nd plate. Thus each plate appears successively before the jet and the jet exerts force on each plate. The wheel starts moving at a constant speed.

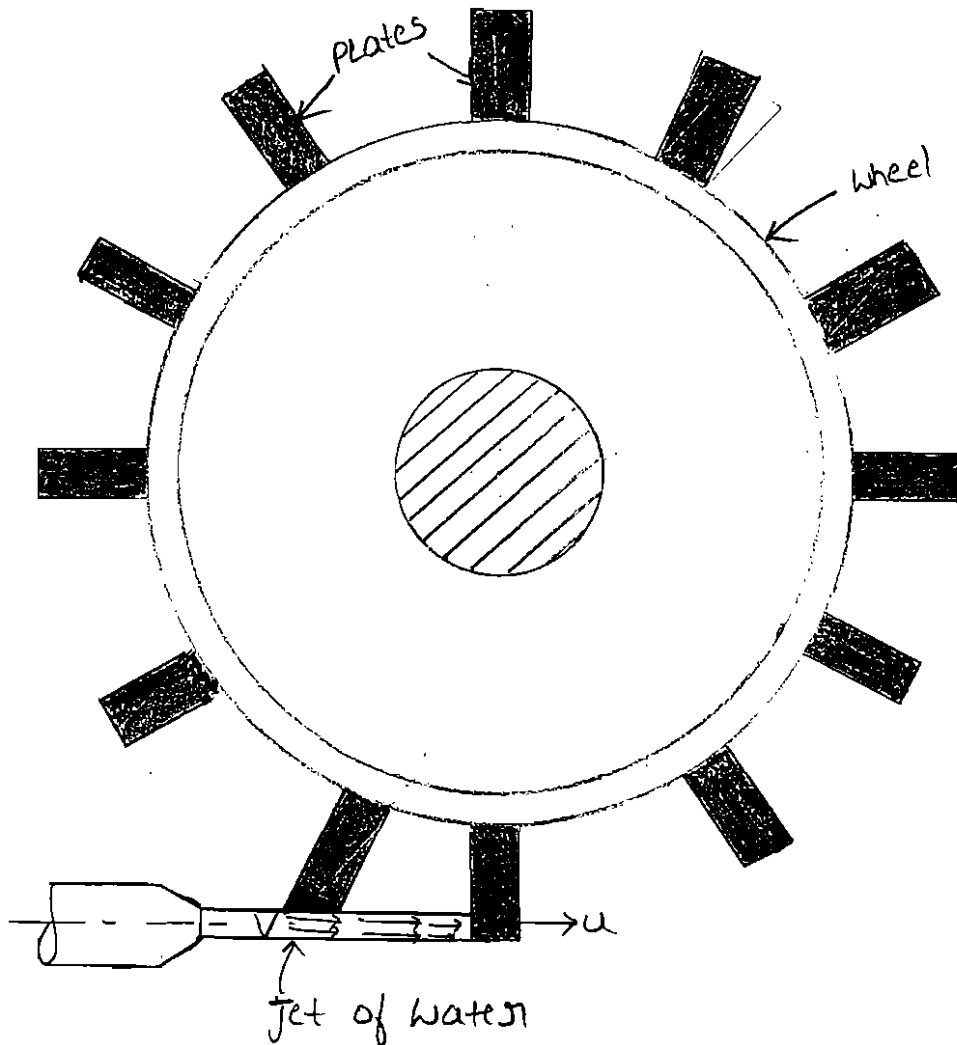

fig. Jet striking a series of vanes

Let $v =$ velocity of jet,

$d =$ diameter of jet

$a =$ cross-sectional area of jet

$$= \frac{\pi}{4} d^2$$

$u =$ velocity of vane

In this case the mass of water coming out from the nozzle per second is always in contact with the plates, when all the plates are considered. Hence mass of water per second striking the series of plates $= \rho a v$.

Also the jet strikes the plate with a velocity $= (v - u)$

After striking the jet moves tangential to the plate and hence the velocity component in the direction of motion of plate is equal to zero.

\therefore The force exerted by the jet in the direction of motion of plate

$$F_x = \text{mass per second} [\text{Initial velocity} - \text{final velocity}]$$

$$= \rho a v [(v - u) - 0]$$

$$= \rho a v [v - u]$$

Work done by the jet on the series of plates per second

$$= \text{force} \times \text{Distance per second in the direction of force}$$

$$= F_x u$$

$$= \rho a v [v - u] \times u$$

K.E of the jet per second

$$= \frac{1}{2} m v^2 \Rightarrow \frac{1}{2} (\rho a v) \times v^2 \Rightarrow \frac{1}{2} \rho a v^3$$

$$\therefore \text{Efficiency, } \eta = \frac{\text{Work done per second}}{\text{Kinetic energy per second}} = \frac{\rho a v [v - u] \times u}{\frac{1}{2} \rho a v^3}$$

$$= \frac{2u(v-u)}{v^2}$$

UNIT - IV

SHORT ANSWER QUESTIONS

1. Show that the force exerted by a jet of water on moving inclined plate in the direction of jet is given by $F_x = \rho a(V-u)^2 \sin^2\theta$.
2. Derive an expression for the force exerted by a jet of water on stationary inclined plate in the direction of jet.
3. List out the applications of impact of free jets.
4. Explain the basic principle involved in the impact of free jets.
5. Write an expression for the force exerted by the jet on the stationary plate in the direction of jet
 - (i) When flat plate is held normal to the jet
 - (ii) When the flat plate is held inclined to the jet.
6. Write an expression for the force exerted by the jet on the moving plate in the direction of jet
 - (i) When flat plate is held normal to the jet
 - (ii) When the flat plate is held inclined to the jet.
7. Define the term Impacts of jets.
8. Obtain an expression for the force exerted by a jet of water on a fixed vertical plate in the direction of the jet.
9. Define the term Jet propulsion.
10. What is the importance of inclined and curved plates when the plates are moving in the direction of jet.
11. Derive the expression for force exerted by a jet when it strikes an inclined flat plate which is moving in the same direction as the jet.
12. What is impulse momentum principle?
13. Derive the expression for the force exerted by a water jet on a plate moving in the same direction of the jet with a velocity less than that of the jet.
14. Differentiate between the force exerted by a jet of water on a fixed vertical plate and moving vertical plate.
15. Differentiate between the force exerted by a jet on a single curved moving plate and a series of curved moving plate.
16. Prove that the force exerted by a jet of water on a fixed semi-circular plate in the direction of the jet when the jet strikes at the center of the semi-circular plate is two times the force exerted by the jet on an fixed vertical plate.

UNIT IV

ESSAY ANSWER QUESTIONS

1. A 75 mm diameter jet having a velocity of 30m/s strikes a flat plate, the normal of which is inclined at 45° to the axis of the jet. Find the normal pressure on the plate when it is moving with a velocity of 15 m/s in the direction of the jet, away from the jet. Also determine the power and efficiency of the jet when the plate is moving.
2. A jet of water from a nozzle is deflected through 60° from its original direction by curved plate which it enters tangentially without the shock with a velocity of 30 m/s and leaves with a mean velocity of 25 m/s. If the discharge from the nozzle is 0.8 kg/s, Calculate the magnitude and direction of the resultant force on the vane, if the vane is stationary.
3. A 30 mm diameter jet strikes without shock on a series of vanes. The jet velocity is 60 m/s and the vanes move in the same direction as the jet. The shape of each vane is such that, when stationary, it would deflect the jet through an angle of 150°. The friction reduces the relative velocity by 10% as water flows across the vanes and there is a further wind age loss is given by $\frac{u^2}{2}$ Nm/kg of water, where u is the vane speed. Determine:
 - (i) The velocity of vanes corresponding to maximum efficiency, and
 - (ii) The corresponding thrust on the vanes in the direction of motion.
4. The rotor of inward flow hydraulic turbine has a diameter over the tips of the moving vanes of 1.2 m. The diameter at the bottom of the vanes is 0.72 m. The speed is 300 rpm. The water is supplied through fixed vanes at 100° to the tangent to the outer circumference of the rotor, the velocity of water being 12m/s. If the water leaves the moving vanes with the velocity entirely radial and equal to 4.2 m/s, determine:
 - (i) The blade angles at entry and exit, so that the water may enter and leave the moving blades without shock.
 - (ii) The velocity of water relative to the vanes at the exit.
5. A jet of water of diameter 150 mm strikes a flat plate normally with a velocity of 12 m/s. The plate is moving with a velocity of 6 m/s in the direction of the jet and away from the jet. Find: (i) The force exerted by the jet on the plate, (ii) Work done by the jet on the plate per second, (iii) power of the jet, and (iv) efficiency of the jet.
6. A jet of water having a velocity of 20 m/s strikes a curved vane which is moving with a velocity of 9 m/s. The vane is symmetrical and is so shaped that the jet is deflected through 120°. Find the angle of the jet at inlet of the vane so that there is no shock. What is the

absolute velocity of the jet at outlet in magnitude and direction and the work done per second per unit weight of water striking? Assume the vane to be smooth.

7. A jet of water having a velocity of 30 m/s strikes a curved vane, which is moving with a velocity of 15 m/s. The jet makes an angle of 30° with the direction of motion of vane at inlet and leaves at an angle of 120° to the direction of motion of vane at outlet. Calculate: (i) Vane angles, If the water enters and leaves the vane without shock, (ii) Work done per second per unit weight of water striking the vanes per second.
8. A jet of water of diameter 50 mm, having a velocity of 30 m/s strikes a curved vane which is moving with a velocity of 15 m/s in the direction of the jet. The jet leaves the vane at an angle of 60° to the direction of motion of vanes at outlet. Determine: (i) The force exerted by the jet on the vane in the direction of motion, (ii) work done per second by the jet.
9. A jet of water of diameter 100 mm strikes a curved plate at its centre with a velocity of /s. The curved plate is moving with a velocity of 7 m/s in the direction of the jet. The jet is deflected through an angle of 150° . Assuming the plate smooth find (i) force exerted on the plate in the direction of the jet (ii) power of the jet (iii) efficiency.
10. A jet of water strikes with a velocity of 40 m/s a flat plate inclined at 30° with the axis of the jet. If the cross sectional area of the jet is 25 cm^2 determine the force exerted by the jet on the plate.
11. A jet of water 50 mm in diameter and moving with a velocity of 26 m/s is impinging normally on a plate. Determine the pressure on the plate when it is fixed and when it is moving with a velocity of 10 m/s in the direction of the jet. Also determine the work done per second by the jet.
12. A jet of water 50 mm in diameter moving with velocity of 15 m/s impinges on a series of vanes moving with a velocity of 6m/s. Find the force exerted by the jet work done by the jet and efficiency of the jet.
13. A stationary vane having an inlet angle of zero degree and an outlet angle of 250° receives water at velocity of 50 m/s. Determine the component of force acting on it in the direction of the jet velocity and normal to it. Also find the resultant force in magnitude and direction per kg of flow.
14. Find the force exerted by a jet of water of diameter 80 mm on a stationary flat plate when the jet strikes the plate normally with velocity of 20 m/s.

15. A 25mm diameter jet exerts a force of 1kN in the direction of flow against a flat plate which is held inclined at an angle of 30° with the axis of the stream. Find the rate of flow.
16. A jet of water having a velocity of 30 m/s impinges on a series of vanes with a velocity of 15 m/s. The jet makes an angle of 30° to the direction of motion of vanes when entering and leaves at an angle of 120° . Sketch velocity triangles at entrance and exit and determine the vane angles so that the water enters and leaves without shock.
17. A blade turns the jet of diameter 3 cm at a velocity of 20 m/s by 60° . Determine the force exerted by the blade on the fluid.
18. A water jet 20 mm in diameter and having a velocity of 90 m/s strikes series of moving blades in a wheel. The direction of the jet makes 20° with the direction of movement of the blade. The blade angle at inlet is 35° . If the jet should enter the blade without striking, what should be the blade velocity? If the outlet angle of the blade is 30° , determine the force on the blade. Assume that there is no friction involved in the flow over the blade.
19. A jet of water of diameter 50 mm moving with a velocity of 20 m/s strikes a fixed plate in such a way that the angle between the jet and the plate is 60° . Find the force exerted by the jet on the plate (i) in the direction normal to the plate, and (ii) in the direction of the jet.
20. Find the force exerted by a jet of water of diameter 100 mm on a stationary flat plate, when the jet strikes the plate normally with a velocity of 30 m/s.