



UNIT 4

Moment of Inertia

&

Mass Moment of Inertia



MOMENT OF INERTIA

UNIT IV

Introduction

- The moment of force about any point is defined as product of force and perpendicular distance between direction of force and point under consideration. It is also called as first moment of force.
- In fact, moment does not necessary involve force term, a moment of any other physical term can also be determined simply by multiplying magnitude of physical quantity and perpendicular distance. Moment of areas about reference axis has been taken to determine the location of centroid. Mathematically it was defined as,

Moment = area x perpendicular distance.

$$M = (A \times y)$$

- If the moment of moment is taken about same reference axis, it is known as moment of inertia in terms of area, which is defined as,

Moment of inertia = moment x perpendicular distance.

$$I_A = (M \times y) = A \cdot y \times y = A y^2$$

- Where I_A is area moment of inertia, A is area and 'y' is the distance between centroid of area and reference axis. On similar notes, moment of inertia is also determined in terms of mass, which is defined as,

$$I_m = mr^2$$

- Where 'm' is mass of body, 'r' is distance between center of mass of body and reference axis and I_m is mass of moment of inertia about reference axis. It must be noted here that for same area or mass moment of inertia will be change with change in location of reference axis.



➤ **Theorem of parallel Axis: -**

- It states, “If the moment of inertia of a plane area about an axis through its center of gravity is denoted by I_G , then moment of inertia of the area about any other axis AB parallel to the first and at a distance ‘h’ from the center of gravity is given by,

$$I_{AB} = I_G + ah^2$$

- Where I_{AB} = moment of inertia of the area about AB axis

I_G = Moment of inertia of the area about centroid

a = Area of section

h = Distance between center of gravity (centroid) of the section and axis AB.

Proof: -

- Consider a strip of a circle, whose moment of inertia is required to be found out a line ‘AB’ as shown in figure.

Let d_a = Area of the strip.

y = Distance of the strip from the C.G. of the section

h = Distance between center of gravity of the section and the ‘AB’ axis.

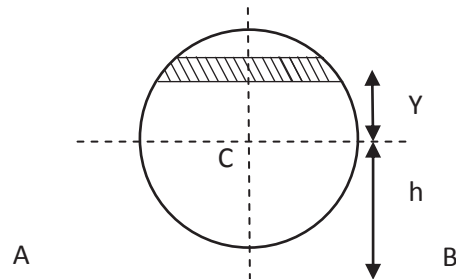

- We know that moment of inertia of the whole section about an axis passing through the center of gravity of the section.

$$= d_a y^2$$

- And M.I of the whole section about an axis passing through centroid.

$$I_G = \Sigma d_a y^2$$

- Moment of inertia of the section about the AB axis

$$\begin{aligned} I_{AB} &= \Sigma d_a (h+y)^2 \\ &= \Sigma d_a (h^2 + 2hy + y^2) \\ &= ah^2 + I_G \end{aligned}$$

- It may be noted that $\Sigma d_a h^2 = ah^2$ and $\Sigma y^2 d_a = I_G$ and $\Sigma d_a y$ is the algebraic sum of moments of all the areas, about an axis through center of gravity of the section and is equal $a\bar{y}$, where \bar{y} is the distance between the section and the axis passing through the center of gravity which obviously is zero.



➤ **Theorem of Perpendicular Axis: -**

- It states, If I_{XX} and I_{YY} be the moment of inertia of a plane section about two perpendicular axis meeting at 'o' the moment of inertia I_{ZZ} about the axis Z-Z, perpendicular to the plane and passing through the intersection of X-X and Y-Y is given by,

$$I_{ZZ} = I_{XX} + I_{YY}$$

Proof: -

- consider a small lamina (P) of area 'd_a' having co-ordinates as ox and oy two mutually perpendicular axes on a plane section as shown in figure.
- Now, consider a plane OZ perpendicular ox and oy. Let (r) be the distance of the lamina (p) from z-z axis such that op = r.

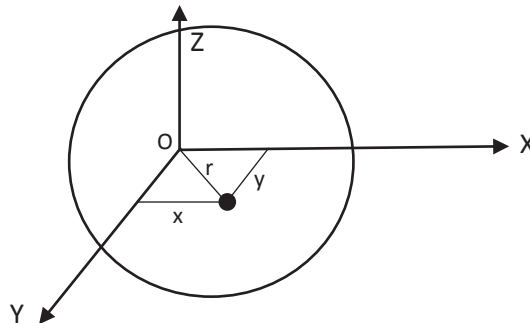

- From the geometry of the figure, we find that,

$$r^2 = x^2 + y^2$$
- We know that the moment of inertia of the lamina 'p' about x-x axis,

$$I_{XX} = d_a \cdot y^2$$

$$\text{Similarly, } I_{YY} = d_a \cdot x^2$$

$$\text{and } I_{ZZ} = d_a \cdot r^2$$

$$= d_a (x^2 + y^2)$$

$$= d_a \cdot x^2 + d_a \cdot y^2$$

$$I_{ZZ} = I_{XX} + I_{YY}$$



➤ Moment of Inertia of a Rectangular Section: -

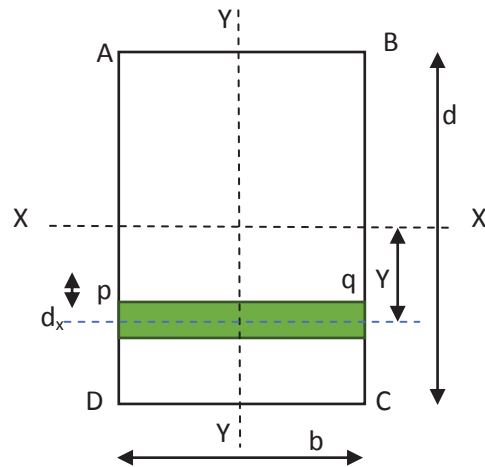

- Consider a rectangular section ABCD as shown in fig. whose moment of inertia is required to be found out.
- Let, b = width of the section
 d = Depth of the section
- Now, consider a strip PQ of thickness d_y parallel to x-x axis and at a distance y -from it as shown in fig.

$$\text{Area of strip} = b \cdot d_y$$

- We know that moment of inertia of the strip about x-x axis,

$$= \text{Area} \times y^2$$

$$= (b \cdot d_y) y^2$$

- Now, moment of inertia of the whole section may be found out by integrating the about equation for the whole length of the lamina i.e. from $-d/2$ to $+d/2$

$$I_{XX} = \int_{-d/2}^{+d/2} b \cdot y^2 d y$$

$$I_{XX} = b \int_{-d/2}^{+d/2} y^2 d y$$

$$= \left[\frac{y^3}{3} \right]_{-d/2}^{+d/2}$$

$$= \frac{bd^3}{12}$$

$$\text{Similarly, } I_{YY} = \frac{db^3}{12}$$

If it is square section,

$$I_{xx} = I_{yy} = \frac{b^4}{12} = \frac{d^4}{12}$$



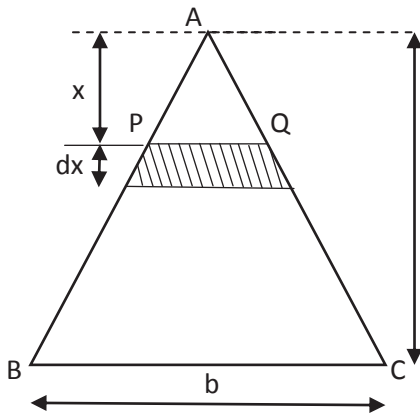

Let, b = Base of the triangular section.

h = height of the triangular section.

Now, consider a small strip PQ of thickness 'dx' at a distance from the vertex A as shown in figure, we find that the two triangle APQ and ABC are similar.

$$\frac{PQ}{BC} = \frac{x}{h} \quad \text{or} \quad PQ = \frac{BC \cdot x}{h} = \frac{b \cdot x}{h}$$

We know that area of the strip PQ = $\frac{b \cdot x}{h} dx$

$$\begin{aligned} \text{And moment of inertia of the strip about the base BC} \\ &= \text{Area} \times (\text{Distance})^2 \\ &= \frac{b \cdot x}{h} dx (h-x)^2 \end{aligned}$$

- Now, moment of inertia of the whole triangular section may be found out by integrating the above equation for the whole height of the triangle i.e. from 0 to h.

$$\begin{aligned} I_{BC} &= \int_0^h \frac{b \cdot x}{h} (h-x)^2 dx \\ &= \frac{b}{h} \int_0^h (h^2 + x^2 + 2hx) x dx \\ &= \frac{b}{h} \left[\frac{x^2 y^2}{2} + \frac{x^4}{4} + \frac{2hx^3}{3} \right]_0^h \\ I_{BC} &= \frac{bh^3}{12} \end{aligned}$$

- We know that the distance between center of gravity of the triangular section and Base BC,

$$d = \frac{h}{3}$$

- so, Moment of the inertia of the triangular section about an axis through its center through its center of gravity parallel to x-x axis,

$$\begin{aligned} I_G &= I_{BC} - ad^2 \\ &= \frac{bh^3}{12} - \frac{bh}{3} \left(\frac{h}{3}\right)^2 \\ I_G &= \frac{bh^3}{36} \end{aligned}$$

Note: - The moment of inertia of section about an axis through its vertex and parallel to the base.

$$\begin{aligned} I_{\text{top}} &= I_G + ad^2 \\ &= \frac{bh^3}{36} + \left(\frac{bh}{3}\right) \left(\frac{2h}{3}\right)^2 \\ &= \frac{9bh^3}{36} \\ &= \frac{bh^3}{4} \end{aligned}$$

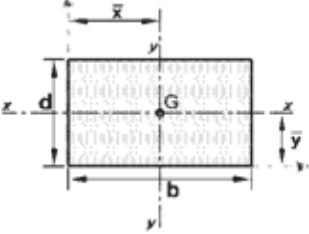
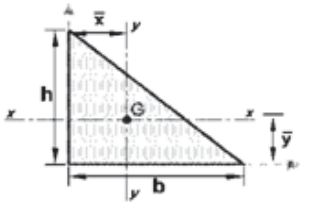
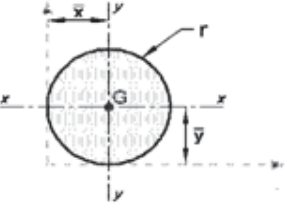
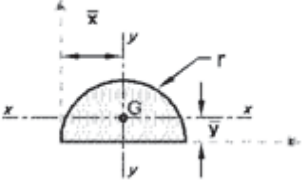
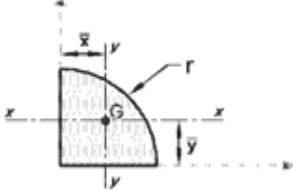

Area (Lamina) Element – Moment of Inertia (Basic Shape)				
Element name	Geometrical Shape	Area	I_{xx}	I_{yy}
Rectangle		bd	$\frac{bd^3}{12}$	$\frac{db^3}{12}$
Triangle		$\frac{1}{2}bh$	$\frac{bh^3}{36}$	$\frac{hb^3}{36}$
Circle		πr^2	$\frac{\pi d^4}{64}$	$\frac{\pi d^4}{64}$
Semicircle		$\frac{\pi r^2}{2}$	$0.11 r^4$	$\frac{\pi d^4}{128}$
Quarter circle		$\frac{\pi r^2}{4}$	$0.055 r^4$	$0.055 r^4$

d= diameter



Example – 1: Find out moment of inertia at horizontal and vertical centroid axes, top and bottom edge of the given lamina.

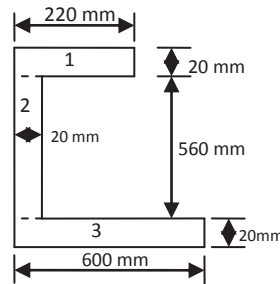

Answer: -

1) centroid of given lamina

Let's divide the given lamina in to three Rectangle

- (1) Top rectangle 200 x 20 mm²
- (2) Middle rectangle 20 x 600 mm²
- (3) Bottom rectangle 580 x 20 mm²

Sr no	Shape	Area (mm ²)	X (mm)	Y (mm)	AX (mm ²)	AY (mm ²)
1	1	$A_1 = 200 \times 20 = 4000$	$X_1 = 20 + \frac{200}{2} = 120$	$Y_1 = 20 + 560 + \frac{20}{2} = 590$	$A_1 X_1 = 480,000$	$A_1 Y_1 = 2,36,0000$
2	2	$A_2 = 600 \times 20 = 12000$	$X_2 = \frac{20}{2} = 10$	$Y_2 = \frac{600}{2} = 300$	$A_2 X_2 = 1,20,000$	$A_2 Y_2 = 3,60,0000$
3	3	$A_3 = 580 \times 20 = 11600$	$X_3 = \frac{580}{2} + 20 = 310$	$Y_3 = \frac{20}{2} = 10$	$A_3 X_3 = 35,96,000$	$A_3 Y_3 = 116000$
		$\Sigma A = 27600$			$\Sigma AX = 4196000$	$\Sigma AY = 6076000$

$$\bar{Y} = \frac{\Sigma AY}{\Sigma A} = \frac{6076000}{27600} = 220.15 \text{ mm}$$

$$\bar{X} = \frac{\Sigma AX}{\Sigma A} = \frac{4196000}{27600} = 152.03 \text{ mm}$$

(2) Moment of inertia about centroid horizontal axis: -

Sr No	Area (mm ²)	h (mm)	Ah ² (mm ⁴)	I _G (mm ⁴)	I _{XX} = I _G + Ah ²
1	$A_1 = 4000$	$h_1 = y_t - \frac{d_1}{2} = 369.85$	$A_1 h_1^2 = 5.4716 \times 10^8$	$I_{G1} = b_1 h_1^3 / 12 = 1.33334 \times 10^5$	$I_1 = 5.4729 \times 10^8$
2	$A_2 = 12000$	$h_2 = y_t - \frac{d_2}{2} = 79.85$	$A_2 h_2^2 = 7.6512 \times 10^7$	$I_{G2} = b_2 h_2^3 / 12 = 3.6 \times 10^8$	$I_2 = 4.3651 \times 10^8$
3	$A_3 = 11600$	$h_3 = y_b - \frac{d_3}{2} = 210.15$	$A_3 h_3^2 = 5.1229 \times 10^8$	$I_{G3} = b_3 h_3^3 / 12 = 3.8667 \times 10^5$	$I_3 = 5.1268 \times 10^8$

Now, Moment of inertia at centroid horizontal axis

$$I_{XX} = I_1 + I_2 + I_3 = 1.4965 \times 10^9 \text{ mm}^4$$



(3) Moment of inertia about centroid vertical axis: -

Shape No	Area (mm ²)	h (mm)	Ah ² (mm ⁴)	I _G (mm ⁴)	I _{yy} = I _G + Ah ²
1	A ₁ = 4000	h ₁ = X ₁ - X ₁ = 32.03	A ₁ h ₁ ² = 4.1036 x 10 ⁶	I _{G1} = d ₁ b ₁ ³ /12 = 1.33334 x 10 ⁷	I ₁ = 1.7437 x 10 ⁷
2	A ₂ = 12000	h ₁ = X ₁ - X ₂ = 142.03	A ₂ h ₂ ² = 2.4207 x 10 ⁸	I _{G2} = d ₂ b ₂ ³ /12 = 4 x 10 ⁵	I ₂ = 2.4247 x 10 ⁸
3	A ₃ = 11600	h ₁ = X ₃ - X ₁ = 310	A ₃ h ₃ ² = 1.1148 x 10 ⁹	I _{G3} = d ₃ b ₃ ³ /12 = 3.2519 x 10 ⁸	I ₃ = 1.4399 x 10 ⁹

Now, Moment of inertia at centroidal axis

$$I_{yy} = I_1 + I_2 + I_3$$

$$= 1.6998 \times 10^9 \text{ mm}^4$$

(4) Moment of inertia about top edge of horizontal axis: -

Shape no	Area (mm ²)	h (mm)	Ah ² (mm ⁴)	I _G (mm ⁴)	I _{tt} = I _G + Ah ²
1	A ₁ = 4000	h ₁ = $\frac{d_1}{2}$ = 10	A ₁ h ₁ ² = 4 x 10 ⁵	I _{G1} = b ₁ d ₁ ³ /12 = 1.33334 x 10 ⁵	I ₁ = 5.3334 x 10 ⁵
2	A ₂ = 12000	h ₂ = $\frac{d_2}{2}$ = 300	A ₂ h ₂ ² = 1.08 x 10 ⁹	I _{G2} = b ₂ d ₂ ³ /12 = 3.6 x 10 ⁹	I ₂ = 1.44 x 10 ⁹
3	A ₃ = 11600	h ₃ = $\frac{d_3}{2}$ = 590	A ₃ h ₃ ² = 4.038 x 10 ⁹	I _{G3} = b ₃ d ₃ ³ /12 = 3.8667 x 10 ⁵	I ₃ = 4.0384 x 10 ⁹

Now, Moment of inertia at top edge of horizontal axis

$$I_{tt} = I_1 + I_2 + I_3$$

$$= 5.4789 \times 10^9 \text{ mm}^4$$

(5) Moment of inertia about bottom edge of horizontal axis: -

Shape no	Area (mm ²)	h (mm)	Ah ² (mm ⁴)	I _G (mm ⁴)	I _{bb} = I _G + Ah ²
1	A ₁ = 4000	h ₁ = d ₂ - $\frac{d_1}{2}$ = 590	A ₁ h ₁ ² = 1.3924 x 10 ⁹	I _{G1} = b ₁ d ₁ ³ /12 = 1.33334 x 10 ⁵	I ₁ = 1.3925 x 10 ⁹
2	A ₂ = 12000	h ₂ = $\frac{d_2}{2}$ = 300	A ₂ h ₂ ² = 1.08 x 10 ⁹	I _{G2} = b ₂ d ₂ ³ /12 = 3.6 x 10 ⁵	I ₂ = 1.44 x 10 ⁹
3	A ₃ = 11600	h ₃ = $\frac{d_3}{2}$ = 10	A ₃ h ₃ ² = 1.16 x 10 ⁶	I _{G3} = b ₃ d ₃ ³ /12 = 3.8667 x 10 ⁵	I ₃ = 1.5467 x 10 ⁶

Now, Moment of inertia at bottom edge of horizontal axis

$$I_{tt} = I_1 + I_2 + I_3$$

$$= 2.834 \times 10^9 \text{ mm}^4$$



Example-2: Determine moment of inertia of a section shown in figure about horizontal centroid axis.

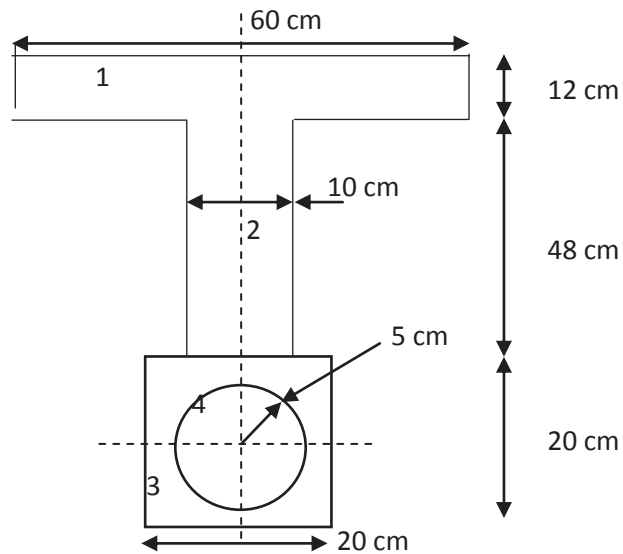

Answer: -

(1) Centroid of given lamina

Let's divide the given lamina in to four part

- (i) Top rectangular 60 x 12 cm²
- (ii) Middle rectangular 10 x 48 cm²
- (iii) Bottom square 20 x 20 cm²
- (iv) Deduct circle of radius 5 cm from bottom square

SR NO.	Shape	Area (cm ²)	Y (cm)	AY (cm ³)
1	1	$A_1 = 60 \times 12 = 720$	$Y_1 = 20 + 48 + \frac{12}{2} = 74$	$A_1 Y_1 = 34560$
2	2	$A_2 = 10 \times 48 = 480$	$Y_2 = 20 + \frac{48}{2} = 300$	$A_2 Y_2 = 21120$
3	3	$A_3 = 20 \times 20 = 400$	$Y_3 = \frac{20}{2} = 10$	$A_3 Y_3 = 4000$
4	4	$A_4 = -\pi r^2 = -78.54$	$Y_4 = \frac{20}{2} = 10$	$A_4 Y_4 = -785.4$
		$\Sigma A = 1521.46$		$\Sigma AY = 58894.6$

$$\bar{Y} = \frac{\Sigma AY}{\Sigma A} = \frac{58894.6}{1521.46} = 38.70 \text{ cm}$$



(2) Moment of inertia about centroid horizontal axis: -

Shape no	Area (cm ²)	h (cm)	Ah ² (cm ⁴)	I _G (cm ⁴)	I _{XX} = I _G + Ah ²
1	A ₁ = 720	$h_1 = y_t - \frac{d_1}{2} = 35.3$	$A_1 h_1^2 = 897.1 \times 10^3$	$I_{G1} = b_1 h_1^3 / 12 = 8640$	I ₁ = 905824.8
2	A ₂ = 480	$h_2 = y_t - \frac{d_2}{2} = 17.3$	$A_2 h_2^2 = 143.65 \times 10^3$	$I_{G2} = b_2 h_2^3 / 12 = 92160$	I ₂ = 235819.2
3	A ₃ = 400	$h_3 = y_b - \frac{d_3}{2} = 28.7$	$A_3 h_3^2 = 329.4 \times 10^3$	$I_{G3} = b_3 h_3^3 / 12 = 13333.34$	I ₃ = 342809.34
4	A ₄ = 78.54	H ₄ = 28.7	$A_4 h_4^2 = -64.6 \times 10^3$	$I_{G3} = \pi d^4 / 64 = -490.8$	I ₃ = -65183.48

Now, Moment of inertia at centroid horizontal axis

$$I_{XX} = I_1 + I_2 + I_3$$

$$= 1.419 \times 10^6 \text{ cm}^4$$

Example-3: - Find the moment of inertia about Y-axis and X-axis for the area shown in fig.

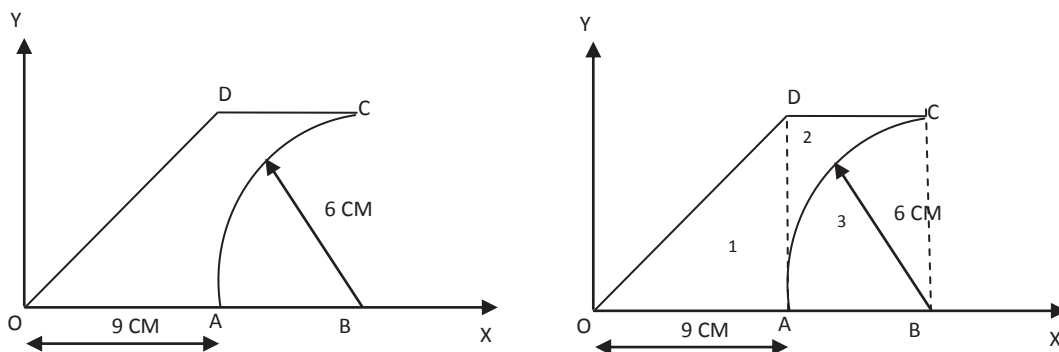

(1) Moment of inertia about x- axis (o-x line)

Sr No	Area (cm ²)	h (cm)	Ah ² (cm ⁴)	I _G (cm ⁴)	I _{OX} = I _G + Ah ²
1	A ₁ = 1/2 bh = 4000	$h_1 = \frac{h}{3} = 2$	$A_1 h_1^2 = 108$	$I_{G1} = bh^3 / 36 = 54$	I ₁ = 162
2	A ₂ = d x d = 12000	$h_2 = \frac{d}{2} = 3$	$A_2 h_2^2 = 324$	$I_{G2} = d^4 / 12 = 108$	I ₂ = 432
3	$A_3 = \frac{\pi}{4} r^2 = 11600$	$h_3 = \frac{4r}{3\pi} = 2.55$	$A_3 h_3^2 = 183.35$	$I_{G3} = 0.055r^4 = 71.28$	I ₃ = 254.62

Now, Moment of inertia at centroid horizontal axis

$$I_{XX} = I_1 + I_2 + I_3$$

$$= 339.37 \text{ cm}^4$$

(2) Moment of inertia about y- axis (OY - line)

Shape no	Area (cm ²)	h (cm)	Ah ² (cm ⁴)	I _G (cm ⁴)	I _{OY} = I _G + Ah ²
1	A ₁ = 27	h ₁ = 6	$A_1 h_1^2 = 972$	$I_{G1} = b^3 h / 36 = 121.5$	I ₁ = 1093.5
2	A ₂ = 12	h ₂ = 12	$A_2 h_2^2 = 5184$	$I_{G2} = d^4 / 12 = 108$	I ₂ = 5292
3	A ₃ = 12.45	h ₃ = 12.45	$A_3 h_3^2 = 4381.9$	$I_{G3} = 0.055r^4 = 71.28$	I ₃ = 4456.35

Now, Moment of inertia at centroid horizontal axis

$$I_{XX} = I_1 + I_2 - I_3$$

$$= 1929.15 \text{ cm}^4$$



Tutorial Questions

1. From first principles deduce an expression to determine the Moment of Inertia of a triangle of base 'b' and height 'h'
2. Find the moment of inertia about the horizontal centroidal axis.

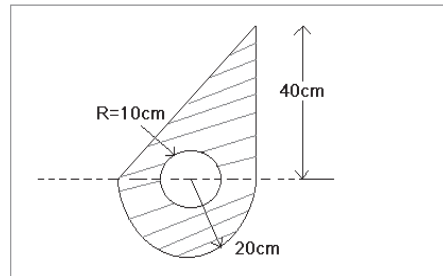

3. Determine the mass moment of inertia of sphere about its diametrical axis
4. Determine moment of inertia of a quarter circle having the radius 'r'
5. Locate the centroid and calculate moment of inertia about horizontal and vertical axis through the centroid as shown in figure



Assignment Questions

1. Find the moment of Inertia of the given figure

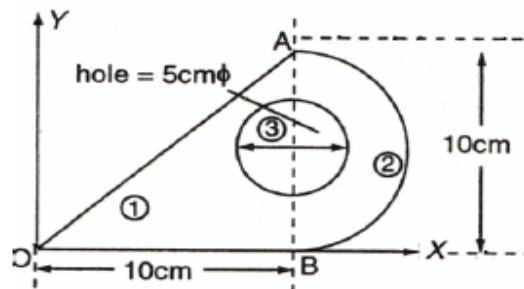

2. Find the mass moment of inertia of a circular plate about centroidal axis
3. Determine the Mass moment of inertia a solid sphere of Radius R about its diametrical axis
4. Determine the mass moment of Inertia of Rod of Length L
5. Find the Moment of inertia of the shaded area shown in figure about Centroidal X and Y axis. All dimensions are in cm.

